

# The Changing Face of Irrigation in Kenya

## Opportunities for Anticipating Change in Eastern and Southern Africa

Herbert G. Blank, Clifford M. Mutero  
and Hammond Murray-Rust, editors



# The Changing Face of Irrigation in Kenya



# **The Changing Face of Irrigation in Kenya: Opportunities for Anticipating Changes in Eastern and Southern Africa**

**Herbert G. Blank, Clifford M. Mutero and Hammond  
Murray-Rust, editors**

INTERNATIONAL WATER MANAGEMENT INSTITUTE

IWMI receives its principal funding from 58 governments, private foundations and international and regional organizations known as the Consultative Group on International Agricultural Research (CGIAR). Support is also given by the Governments of Ghana, Pakistan, South Africa, Sri Lanka and Thailand.

*The editors:* Chief Editor, Herbert G. Blank is Consultant and former Regional Advisor for eastern and southern Africa, International Water Management Institute (IWMI). Clifford M. Mutero is Regional Representative for eastern Africa, IWMI Coordinator, CGIAR Systemwide Initiative on Malaria and Agriculture (SIMA) and Senior Scientist, International Centre for Insect Physiology and Ecology (ICIPE), Nairobi, Kenya. Hammond Murray-Rust is Theme Leader, Integrated Water Management for Agriculture, IWMI.

Blank, Herbert G., Clifford M. Mutero and Hammond Murray-Rust, eds. 2002. *The changing face of irrigation in Kenya: Opportunities for anticipating change in eastern and southern Africa*. Colombo, Sri Lanka: International Water Management Institute.

*/small-scale systems / water scarcity / farmer-managed irrigation systems / government-managed irrigation systems / irrigated farming / rice / technology transfer / databases / GIS / drainage / drought / sedimentation / land management / river basins / malaria / schistosomiasis / farmers / economic aspects / social conditions / case studies / arid zones / participatory management / water policy / legislation / health / livestock / Kenya / eastern Africa / southern Africa/*

ISBN 92-9090-475-5

*Cover photo, by Martin Fisher of ApproTec, shows Mrs. Kinuyu, a farmer entrepreneur who bought and uses the ApproTec Super MoneyMaker pump to irrigate an acre of cabbage, onion and French bean at Kilimambogo, east of Thilka, Kenya. The two young men in the picture work for her.*

Copyright © 2002, by IWMI. All rights reserved.

Please direct inquiries and comments to: [iwmi-research-news@cgiar.org](mailto:iwmi-research-news@cgiar.org)

# Contents

Foreword by Director General, International Water Management Institute .....	vii
Foreword by Director, Kenya Agricultural Research Institute .....	ix
Acknowledgements .....	xi
Abbreviations and Acronyms .....	xiii
Overview and Summaries of Papers .....	1
<b>Part 1. Setting the Context</b> .....	33
Review of Irrigation Development in Kenya .....	35
<i>Stephen N. Ngigi</i>	
New Irrigation Technologies .....	55
<i>Isaya V. Sijali and Rose A. Okumu</i>	
<b>Part 2. Smallholder Irrigation in the Basin Context</b> .....	73
Use of Geographic Information Systems for Planning and Management of Smallholder Irrigation and Drainage .....	75
<i>Bancy M. Mati</i>	
Preliminary Evaluation of Irrigation Development in Kenya .....	93
<i>Stephen N. Ngigi</i>	
Water Scarcity and Conflicts: A Case Study of the Upper Ewaso Ng'iro North Basin .....	113
<i>Francis N. Gichuki</i>	
Links Between Land Management, Sedimentation, Nutrient Flows and Smallholder Irrigation in the Lake Victoria Basin .....	135
<i>Chin Ong and Frederick Orego</i>	
Impact of Water Scarcity on Pastoral Systems: Experience from the 1995–97 Drought and the 1997–98 El Niño Rains in the Greater Horn of Africa .....	155
<i>Jean Ndikumana</i>	
<b>Part 3. Community Management Issues in Smallholder Irrigation</b> .....	169
Smallholder Management of Irrigation in Kenya .....	171
<i>Woulter Scheltema</i>	
From Government to Farmer-Managed Smallholder Rice Schemes: The Unresolved Case of the Mwea Irrigation Scheme .....	191
<i>Charity Kabutha and Clifford M. Mutero</i>	

Health Impact Assessment of Increased Irrigation in the Tana River Basin, Kenya .....	211
<i>Clifford M. Mutero</i>	
Integrated Pest Management (IPM) Issues in Irrigated Agriculture:	
Current Initiatives and Future Needs to Promote IPM Adoption	
by Smallholder Farmers in Eastern Africa .....	231
<i>S. Sithanatham, A. A. Seif, C. Matoka and C. Mutero</i>	
<b>Part 4. Potential Impacts of Changes in Smallholder Irrigation .....</b>	<b>263</b>
Commercialization of Smallholder Irrigation: Economic and Social Implications	
in Semiarid Areas of Eastern Kenya .....	265
<i>H. Ade Freeman and Said N. Silim</i>	
Water Policy and Law in a Water-Scarce Country: Implications for	
Smallholder Irrigation in Kenya .....	277
<i>Chris Huggins</i>	
<b>Part 5. Regional Relevance .....</b>	<b>301</b>
Relevance of Kenyan Irrigation Experience to Eastern and Southern Africa .....	303
<i>N. Hatibu, H. F. Mahoo and O. B. Mzirai</i>	

# **Foreword**

**by**

## **Director General, International Water Management Institute**

The International Water Management Institute (IWMI) began working in Kenya in 1998 with the stationing of a part-time representative. With this modest start it was clear that progress would only be made through collaboration and partnership with other organizations. Initial collaboration was established with universities and with the International Center of Insect Physiology and Ecology (ICIPE) headquartered in Nairobi, on a program of research on malaria. IWMI's early work included participation in the Association for Strengthening Agricultural Research in East and Central Africa (ASARECA) for the establishment of a regional network on soil and water resources, and collaboration with both the Kenya Agriculture Research Institute (KARI), which was actively involved in a program of smallholder irrigation, and the Irrigation and Drainage Branch of the Ministry of Agriculture and Land Development. In 1999, a decision was made to establish a small office at the International Center for Research on Agroforestry (ICRAF), whose headquarters is also in Nairobi and houses representatives of other CGIAR centers and research institutions.

Issues characterizing irrigation in Kenya are many and varied. Smallholder irrigation schemes present difficult management problems including lack of financing, poor maintenance, absence of functioning farmer support services and low income levels of farmers. While the performance of donor-financed schemes has generally been poor, recently there have been some encouraging results from smallholder irrigators—both individuals and groups—for the production of high-valued crops. Support to this movement has come from several sources, which have provided affordable pumps and other irrigation equipment intended for use by smallholders. IWMI decided to take on the task of taking an initial look at some of the issues of irrigation in Kenya, through a network of researchers who could provide insights into the problems and attempt to evaluate the potential for smallholder irrigation in Kenya.

In an environment of growing scarcity and competition for water, increasing the productivity of water lies at the heart of the CGIAR goals of increasing agricultural productivity, protecting the environment and alleviating poverty. IWMI was designated as the convening center for the System-Wide Initiative on Water Management (SWIM). Improving water management requires dealing with a range of policy, institutional and technical issues. As national agricultural research becomes increasingly involved in the water management issues related to crop production, there is strong complementarity between their work and many of the CGIAR centers that encourage strong collaborative research ties. A consortium of donors including Ford Foundation, Rockefeller Foundation, and the Governments of Australia, Denmark, France, Germany, Netherlands and Republic of China have supported the SWIM agenda. IWMI staff took the initiative to find researchers interested in the topic and created an informal network of researchers from CGIAR centers, KARI, local universities and elsewhere, addressing many, although certainly not all, of the issues facing smallholder



irrigation and the management of Kenya's water resources. The research was partially supported by the African Development Bank as part of the project entitled Inventory of Smallholder Productivity and Evaluation of Low-Cost Precision Irrigation Techniques in Southern and Eastern Africa, and by SWIM.

This publication is intended to contribute to the knowledge base on improved food production and efforts to alleviate poverty in sub-Saharan Africa. As highlighted in the papers, irrigated agriculture, per se, is not a solution but irrigated agriculture with adequate support systems including access to inputs including credit, seeds, fertilizer and downstream markets has the potential to increase incomes of millions of rural poor in the region. We hope that this publication has a wide readership among researchers and practitioners in this field. We expect that most of the lessons and problems discussed in the papers have relevance to other countries, particularly in eastern and southern Africa.

Dr. Herbert Blank was the first IWMI regional advisor for eastern and southern Africa. He was instrumental in establishing IWMI's presence in Kenya and contributed to the establishment of IWMI's regional office in South Africa. Dr. Clifford Mutero succeeded Dr. Blank and has expanded the program and led a System-Wide Initiative on Malaria and Agriculture. Dr. Hammond Murray-Rust, IWMI's Theme Leader for Integrated Water Management for Agriculture, conceptualized the study and was the initial stimulus for this research.

Prof. Frank Rijsberman  
Director General  
International Water Management Institute

**Foreword**  
**by**  
**Director, Kenya Agricultural Research Institute**

Kenya's economy is agriculture-based, yet over 80 percent of the country is classified as arid and semiarid and typically characterized by low (100-1,200 mm per annum) and erratic rainfall, high evapotranspiration rates and generally fragile ecosystems. The water crisis in Kenya is therefore real. Unpredictable rainfall and frequent droughts mean that farmers cannot depend on rain-fed agriculture as a meaningful way to meet their subsistence needs. It is becoming increasingly clear that with increased population and pressure on arable land, the typical smallholder farmer under dryland conditions cannot even provide for his own family's subsistence. While irrigation provides a potential solution, Kenya's experience has been one of mixed results. Some of the papers in this volume document the difficulties that both the government and smallholders face in attempting to maintain irrigation schemes in a sustainable manner. Despite these problems however, there are pockets of success, especially where introduction of new approaches to irrigation has made new technologies available to Kenya's farmers.

The water crisis has resulted in increased competition for water, even to the point of conflict among the varied water users. Villagers need water to meet their domestic needs, pastoralists are constantly in search of grazing land and water for their livestock and smallholders (agriculturists) need water to grow their crops. All these parties compete for available supplies and, in most cases, not doing much to conserve the resource for continued sustainable use. Having legislation and regulations over water use is not an adequate solution. There is need for local institutions that have the capacity to resolve these water conflicts. Some of the papers in this book address this issue and provide an interesting avenue for Kenya and other countries to pursue.

Irrigation is important to farmers' livelihoods. While the Government of Kenya once provided irrigation facilities to farmers at no cost, this is no longer the case. Farmers now assume a greater, if not the full, investment cost of providing water for their varied uses. In order to meet these costs, farmers need to produce crops that can repay this investment and provide a livelihood for their families. Increasingly, farmers need to move from just the production of staple crops to market-oriented crops that can provide the needed cash incomes. One such rapidly growing area that can be tapped is the horticultural subsector. However, the introduction of these crops and alternatives creates a whole new breed of smallholders, as entrepreneurs whose needs are wide and varied, and who have to be knowledgeable in a whole range of issues including improved agronomic practices, the benefits of fertilizer and pest control, sources of credit and probably, most importantly, the knowledge of markets.

The Kenya Agricultural Research Institute (KARI) has supported smallholder irrigation for many years. Through the promotion and sale of bucket and larger drip-irrigation kits

thousands of farmers have been exposed to opportunities for off-season vegetable production and for the additional income provided by that activity. This and other smallholder irrigation approaches are reported in this book. The transition, from government-provided facilities to farmer investment in equipment, which will make the Kenyan smallholder more productive, is a crucial first step in establishing the entrepreneurial smallholder irrigation. The changing face of irrigation in Kenya is truly exemplified by this movement.

This book raises many issues while pointing to several promising areas as the way forward. Many countries in the region face similar problems and we hope this book will be of value to researchers and practitioners who deal with the important issues of water resources. We acknowledge the contribution from the staff of the Sokoine University and IWMI to this publication and hope that this collaborative effort is one among many more to come.

Romano M. Kiome (PhD; SS)  
Director  
Kenya Agricultural Research Institute

## Acknowledgements

Support for IWMI's work in Africa has come from IWMI's former Director General, Dr. David Seckler and the current DG, Prof. Frank Rijsberman who created and successfully implemented the framework for decentralizing IWMI, placing many more of IWMI's key staff in the field. We would like specifically to thank Dr. Hammond Murray-Rust who conceptualized the study and Dr. Randy Barker and provided the support from SWIM to conduct this study.

We greatly appreciate the support of the African Development Bank, which provided substantial funding for this study and of Dr. Hilmy Sally on the IWMI side who administered these funds.

While SWIM provided the umbrella for collaboration with other CG centers, it was the Center DGs and their representatives in Nairobi who allowed the collaboration to take place. From the CGIAR centers we would particularly like to thank Dr. Said Silim from ICRISAT, Dr. Chin Ong from ICRAF and Dr. Jean Ndikumana from ILRI who worked far beyond their job descriptions to produce these papers. In addition, support from other international and local organizations in Nairobi is appreciated; specifically we would like to thank Dr. S. Sithanantham from ICIPE and to Dr. Chris Huggins from ACTS for their valuable contributions.

We would like to thank our university colleagues who are the stalwarts of African research on irrigation. These include Kenyan colleagues Dr. Francis Gichuki and Dr. Stephen Ngigi from the University of Nairobi and Dr. Bancy Mati from the Jomo Kenyatta University of Agricultural Technology, and Tanzanian colleague Dr. Nuhu Hatibu of the Sokoine University. We would also like to thank all the other authors and researchers who contributed to this volume.

Within the Government of Kenya we would like to especially thank Dr. Romano Kiome, KARI's Director, Mr. C. M. Osoro, the Deputy Director of the Ministry of Agriculture, Land Development Division, and Mr. Abdulrazaq Ali, formerly of the National Irrigation Board.

We would like to give a special thank you to Dr. Douglas J. Merrey, IWMI's Regional Director for Africa who provided the leadership, and kept the study on track and the momentum going despite disruptions caused by staff movements and administrative changes.

Finally, we would particularly like to thank Dr. Jacob Kijne who reviewed the early versions of many of the papers.

Dr. Herbert G. Blank

Dr. Clifford M. Mutero

## Abbreviations and Acronyms

ADB	-	African Development Bank
ALDEV	-	African Land Development Unit
ApproTEC	-	Appropriate Technology Enterprise Creation
ASAL	-	Arid and Semiarid Land
ASIP	-	Agricultural Sector Investment Programme
DALEO	-	District Agricultural, Livestock and Extension Officer
DANIDA	-	Danish International Development Agency
DC	-	District Commissioner
DDC	-	District Development Committee
DIE	-	District Irrigation Engineer
DIU	-	District Irrigation Unit
DWD	-	Department of Water Development
FAO	-	Food and Agriculture Organization of the United Nations
FPEAK	-	Fresh Produce Exporters' Association of Kenya-
GDP	-	Gross Domestic Product
GIS	-	Geographical Information Systems
HCDA	-	Horticultural Crops Development Authority
ICDC	-	Industrial and Commercial Development Corporation
ICIPE	-	International Centre for Insect Physiology and Ecology
IDB	-	Irrigation and Drainage Branch
IDRS	-	Irrigation and Drainage Research Section
IFAD	-	International Fund for Agricultural Development
ILRI	-	International Livestock Research Institute
ITDG	-	Intermediate Technology Development Group
IUCN	-	The World Conservation Union
IWMI	-	International Water Management Institute
JKUAT	-	Jomo Kenyatta University of Agriculture and Technology
JICA	-	Japan International Cooperation Agency
KARI	-	Kenya Agricultural Research Institute
KVDA	-	Kerio Valley Development Authority
LBDA	-	Lake Basin Development Authority
MENR	-	Ministry of Environment and Natural Resources
MoA	-	Ministry of Agriculture
MoA&RD	-	Ministry of Agriculture and Rural Development
MoWD	-	Ministry of Water Development
NCKK	-	National Council of Churches of Kenya
NGO(s)	-	Nongovernment Organization(s)
NIB	-	National Irrigation Board
NORAD	-	Norwegian Agency for International Development
O&M	-	Operation and Maintenance

PIU	-	Provincial Irrigation Unit
SID	-	Smallholder Irrigation and Drainage
SIDP	-	Smallholder Irrigation Development Project
SISDO	-	Smallholder Irrigation Scheme Development Organization
SISO	-	Smallholder Irrigation Schemes Organization
SSIDP	-	Small-Scale Irrigation Development Project
SSIU	-	Small-Scale Irrigation Unit
TARDA	-	Tana and Athi River Development Authority
UNDP	-	United Nations Development Programme

# Overview and Summaries of Papers

The rapid changes in the political economy of Kenya are having a direct impact on the nature of irrigation and the benefits that accrue from investing in modern irrigation technologies. The rapid pace of these changes means that there is an opportunity to use Kenya as an example of similar changes in a number of countries throughout the region.

The main types of irrigated agriculture in Kenya have, traditionally, been as follows:

- Large-scale surface irrigation schemes constructed, operated and maintained by the government in which smallholder farmers play a minor role in management, and are tied to the government for inputs and marketing of crops.
- Smallholder irrigation, either individually or by small groups, that have been able to exploit water in streams and irrigate small areas in valley floors, mostly for domestic food consumption and local markets.
- Agro-industrial irrigation of high-value crops, notably flowers, financed and developed by private corporations or individuals and relying heavily on pump-based technologies in combination with drip or sprinkler irrigation.

With the rapid changes that have occurred in the past 5 years, the boundaries between these three types of irrigation have become blurred. The three most important changes are:

- The capacity of the government to manage large-scale surface systems has collapsed. In the Mwea irrigation scheme, which accounts for over 60 percent of the large-scale systems operated by the National Irrigation Board (NIB), farmers are in the process of taking over the responsibilities of the NIB to operate and maintain the system themselves, despite the lack of any formal management structure or federated water user organization. In many irrigation areas, rules for water allocation and distribution imposed for decades are now in abeyance and new rules and operational strategies are needed to help farmers to effectively manage water into the future.
- Commercialization of smallholder irrigation has enabled some individuals to move away from irrigation of traditional food grain crops and enter the high-value vegetable and fruit market. This has been accomplished in part through smallholder contacts with marketing agents and agro-industrial concerns for such crops as tomato, French bean and organic vegetables.
- New technologies are rapidly being introduced and adopted widely by irrigators. These include motorized pumps, manually operated treadle pumps, low-head drip-irrigation kits and locally manufactured sprinkler and drip systems. Because some of these technologies enable them to lift water, farmers, many of whom are women, can access water sources previously unavailable to them, and they can use water much more effectively on small plots so that potentially they can expand the area they can cultivate.

These changes are likely to result in much improved utilization of the scarce water resources of Kenya and increase the incomes of those who are able to take advantage of the new technologies. However, there are some cautionary lessons that need to be learned from current experiences in Kenya that have a wider regional importance, particularly those that address issues of water rights, environmental degradation, poverty alleviation and equity.

The most critical of these cautionary lessons appear to be:

- The collapse or reduction of government services including subsidies to irrigation, which has resulted in the failure and abandonment of many government-supported schemes.
- The collapse of the capacity of the government to regulate and control access to water resources because much of the new development relies on small pumping and water-lifting devices owned and operated by individuals. This may lead to basin-level problems of access to water, and intensify the adverse impacts of irrigation associated with higher input use, such as conflicts over water, equity concerns, groundwater depletion and undesirable environmental effects.
- Traditional community water rights may be overridden by individually based irrigation developments, resulting in a realignment of access to water to a more entrepreneurial class of farmer.
- Reduced access to water by the very poor and disadvantaged members of the community, including women, who cannot afford the initial investments in new irrigation technology.
- An urgent need to facilitate transfer arrangements in systems where the government has traditionally had management responsibility but can no longer provide these services due to lack of finance and manpower, in a way that protects the rights of tail-end and other less-influential farmers.

Kenya is already experiencing all of these issues and is struggling to find ways in which access to, and exploitation of, water resources for irrigation can be undertaken in such a way as to support increased agricultural production, maintain an acceptable level of equity of access to water, maintain ecologically sensitive land uses, and continue to reduce poverty through improved production of food and cash crops.

The papers in this volume address topics in three broad categories: basin issues, community-management issues and the potential impacts of changes.

IWMI has commissioned a series of papers from individuals in sister CGIAR centers and from national organizations that have been involved in research and implementation in the smallholder irrigation sector. IWMI collaborators include ICIPE, ICRAF, ICRISAT, ILRI and local collaborators including Kenyan universities, Kenya Agricultural Research Institute (KARI) and the African Centre for Technology Studies, an African NGO. The final paper is contributed by the coordinator of the ASARECA Soil and Water Management Network and staff members from Sokoine University of Agriculture (SUA) in Tanzania. This paper puts into context the findings from Kenya, and discusses their significance for the ASARECA and broader regions.



The publication documents a set of experiences invaluable to Kenya and, probably more importantly, will heighten awareness among neighboring countries in eastern and southern Africa that are likely to experience many of the same trends over the coming decades. The main users of the report are expected to be researchers on natural resources, donors and other development professionals with specific interests in water issues.

## **Part 1. Setting the Context**

The first two papers are aimed at introducing the overall situation regarding smallholder irrigation in Kenya, and setting the context in which the other papers are presented. Paper 1 reviews the past development and current trends in smallholder irrigation linked to changes in irrigation technology for water lifting and water distribution, together with the rapidly changing institutional environment in Kenya. Paper 2 describes the new irrigation technologies being introduced in Kenya and indicates their rate of adoption in the past decade.

## **Part 2. Smallholder Irrigation in the Basin Context**

The five papers in this section look at the need to consider smallholder irrigation in the context of river basins. Although each irrigation system may be small, combined they have a significant impact on water resources and water availability, and uncontrolled development and intensification may lead to increased competition and conflict among water users and between different water uses. Paper 3 looks at the role of GIS in inventorying smallholder irrigation systems, identifying their location, their size, their demand for water, crops grown and the number of people involved. It also has potential for identifying where and under what conditions there may be increased conflict and competition. Paper 4 examines issues relating to smallholder irrigation that emerged from a series of three workshops held in different parts of Kenya in 1999 and 2000. Paper 5 looks at a case study where increased intensification of smallholder irrigation has led to conflicts between upstream and downstream users. Paper 6 looks at the impact of poor upstream land management on sedimentation, maintenance and flood damage to downstream irrigation systems, and raises issues of impacts of irrigation development on nutrient discharge into rivers and lakes. Paper 7 looks at competition for water between livestock and irrigation in the drier parts of the country.

## **Part 3. Community Management Issues in Smallholder Irrigation**

The four papers in this section look at issues of community management related to smallholder irrigation. Even though smallholder irrigation may increasingly be an individual activity due to purchase of small lifting devices and adoption of drip kits, there are several concerns that require community involvement. Paper 8 looks historically at the evolution of approaches to small-scale irrigation management in Kenya. Paper 9 examines the case of a large rice-producing system where smallholders are taking over the operation and maintenance (O&M) of the system, and have to cope with significant management and other problems. Paper 10 examines what management inputs are required at the community level to deal with health risks associated

with irrigation, notably those associated with vectors such as malarial mosquitoes. Paper 11 looks at opportunities for integrated pest management and the specific needs by smallholder irrigators producing high-valued crops.

#### **Part 4. Potential Impacts of Changes in Smallholder Irrigation**

The two papers here address a set of issues that looks at the overall need to maintain equity of access to resources, poverty alleviation and income generation. Paper 12 looks at some of the economic and social consequences of commercialization in the smallholder irrigation sector and its impact on both household incomes and access to water if there is unequal access to new irrigation technologies. Paper 13 addresses policy issues for the government that will be required to support the expansion of profitable commercial smallholder irrigation while, at the same time, ensuring that water rights, equity and poverty issues are not ignored.

#### **Part 5. Regional Relevance**

The final paper, contributed by the ASARECA SWM-Net coordinator and staff members of the Sokoine University of Agriculture, looks at the relevance and importance of the Kenyan example to other countries in the region. Commercialization has taken off rapidly in Kenya and other countries will soon be following. By addressing some of the same issues in other countries it is hoped that the Kenyan experience will prove useful in the development of sustainable smallholder irrigation throughout the region.

# Summary—Paper No. 1

## **Review of Irrigation Development in Kenya**

*Stephen N. Ngigi, University of Nairobi*

Food shortages in Kenya pose a recurrent crisis, which cannot be solved through rain-fed agricultural production alone. Kenya has only about 17 percent of its area classified as medium to high potential land with rainfall higher than 700 mm per year and thus suitable for rain-fed agriculture. The remaining arid and semiarid land cannot reliably support agriculture unless technologies such as irrigation and water harvesting are employed. Supporting Kenya's rapidly increasing population will require the use of technologies such as irrigation to support agricultural intensification.

Kenya has a relatively limited irrigation tradition and the majority of existing irrigated areas were developed between 1960 and 1980, although there is evidence that local communities may have practiced some form of irrigation for the last 500 years. Despite strong gains in the 1970s, since 1980 the rate of irrigation development has declined with the area under irrigation now estimated at 84,000 hectares, far less than the potential irrigable area estimated between 244,700 and 539,500 hectares. The government has now realized that group-based irrigation investment is costly and that its limited resources have been overstretched. In recent irrigation development in Kenya, there has been a deliberate effort by the government to promote greater beneficiary participation through cost sharing, cost recovery and gradual liberalization and privatization in an effort to commercialize the agriculture sector. The emphasis now and in the future is to have less government intervention and pursue a balanced policy that incorporates both public and private sectors and beneficiary participation to build self-sustaining systems.

Irrigation projects that had been initially successful have, in many cases, declined in productivity and, in some cases, have been abandoned. There is a need to evaluate past and current irrigation development in Kenya to map out sustainable future strategies. On the other hand, there are a number of innovative approaches being developed and adopted by farmers that, unlike the conventional irrigation systems, are inexpensive and easily manageable and are showing increasing adoption rates by small-scale farmers. These new technologies have not been evaluated to ascertain their technical and socioeconomic performance under the local conditions.

There is a clear indication that something must have gone wrong along the way in the development of group-based irrigation projects in Kenya. This calls for a need to evaluate the genesis of the current situation with a view to identifying what went wrong and formulate possible remedies and future strategies. In addition, the evaluation process also needs to be geared towards collecting data necessary to enhance the development and management of water resources.

Evaluation should be a participatory learning process, which involves all key actors and critical issues that affect irrigation development in Kenya. The process should take cognisance of the fact that the solutions to declining irrigation development could be identified by looking

back at where we started, reviewing the current situation and determining where we want to be in the future. Comparative evaluation of various irrigation schemes vis-à-vis different technologies, water management, socioeconomic factors, crop production and marketing systems, institutional arrangements, sociocultural and gender perspectives, etc., will form the basis of a focused evaluation process.

A review of irrigation development reveals that although Kenya has developed only a small percentage of its potentially irrigable area, it is already experiencing symptoms of water scarcity. The government is struggling to find ways to access and exploit water resources in such a manner as to support increased agricultural production, maintain an acceptable level of equity of access to water, maintain ecologically sensitive land uses and continue to reduce poverty through improved production of food and cash crops.

## Summary—Paper No. 2

### **The Changing Face of Irrigation in Kenya: New Irrigation Technologies**

*Isaya V. Sijali and Rose A. Okumu, Kenya Agricultural Research Institute*

The emergence of small-scale irrigation technologies that poor farmers can easily understand, invest in and use to grow crops for food and cash is important in the changing in the face of irrigation in Kenya. The two main technologies that have been adopted by Kenyan farmers are the small-scale drip-irrigation systems and treadle pumps. These technologies not only reduce the workload on women who are the main users but also improve incomes and family nutrition.

Drip irrigation is not a new technology in Kenya. Large-scale farmers have been using it widely for the past 10 years mainly in large-scale horticulture and flower production for export. Three types of small-scale drip-irrigation systems, bucket, drum and eighth-acre systems, have shown promise in Kenya. The basic small-scale drip-irrigation unit is the bucket kit. This kit comprises two 15-m long drip tubes, having 100 drip emitters, with a capacity to water 100 plants. The bucket-kit system can easily produce sufficient vegetables for home consumption with users even selling the excess. The drum system has a fivefold increase in capacity over the bucket kit while an eighth-acre system equals a twenty-fold increase in plant capacity.

In 1988, two missionaries introduced bucket drip-irrigation kits from Chapin Watermatics. The Kenya Agricultural Research Institute (KARI) got officially involved in the small-scale drip-irrigation technology in August 1996 through a community development program. Since then KARI and other organizations have distributed and promoted kits in Kenya. NGOs have played a key role in disseminating the kit technology. One NGO has targeted more than 1,000 bucket kits for the Kajiado farmers while a church-based organization purchased over 900 bucket kits for Meru and Tharaka. At least ten other NGOs have supplied kits to their target farmers. Over 6,000 kits have now been distributed to smallholder farmers in Kenya. Local entrepreneurs have shown an interest in providing drip-irrigation kits from locally available material, including drip tape that is manufactured in Kenya.

Among the most exciting and potentially beneficial technologies is the range of manually operated pumps that have been used in Kenya. A Kenyan NGO known as ApproTEC, established in 1991, became involved in disseminating the pedal-pump technology, which had originally been developed in Bangladesh. This organization has stimulated market demand for the pumps and helped create a network of manufacturers and sellers of the technology. Kenyan farmers have readily adopted the pump, and ApproTEC has promoted the pump to an expanding market. Nearly 6,000 units have been sold in Kenya through ApproTEC's network of pump manufacturers and distributors and through the promotion of national newspapers and other means.

The Super MoneyMaker, currently sold for about US\$74, can be used for suction lifts up to 6 m and delivery pressure of 13 m. It can be used with low-head sprinklers or a hose pipe to irrigate up to a little more than a hectare (2.5 acres). The pump weighs 15–20 kilograms and is light enough to be carried home for safety. Farmers have reported profits of Ksh 60,000

(\$800) or more per season using the pump. The potential for micro-irrigation pumps in Kenya has been estimated to be over 360,000 units. So far, only about 2 percent of that potential has been exploited.

Poverty is probably the greatest challenge to the adaptation of small-scale irrigation technologies. While the technologies enable farmers to work their way out of poverty, poor farmers do not have the funds to purchase the equipment. Along with the technologies, therefore, ways and means should be found for these farmers to access the necessary capital.

With the new technologies, farmers need to better address production strategies. For maximum return on investment, production has to be market-driven. Farmers need to target their production to off-season periods when prices are highest. Farmers need to get organized in order to aim at other market outlets including producing for export. To avoid exploitation by middlemen, farmers need better access to market information and strengthened farmer organizations and networks. There is a need for continued development and adaptation of the technologies and programs to teach farmers how to use them, as has occurred in Asia.

## Summary—Paper No. 3

### **The Use of Geographic Information Systems for Planning and Management of Smallholder Irrigation and Drainage**

*Bancy M. Mati, Jomo Kenyatta University of Agricultural Technology*

As the world moves into the information age, meaningful data are becoming the major currency. The value and use of data, and their ultimate form “information” are a basic necessity. In a country such as Kenya, where water scarcity and reliability are major constraints for development, more information is required for policy makers and administrators to make decisions concerning allocation and development plans. Previous attempts to put together a database of irrigation and drainage in Kenya have relied on ad hoc studies, which provided detailed information for specific projects. These databases were not spatially geo-referenced to permit easy access, analysis and updating of new information. Therefore, there was a need for a more flexible and reliable database, such as Geographic Information Systems (GIS).

With assistance from the African Development Bank, IWMI and its partners updated the existing database and put it into a GIS form. The Irrigation and Drainage Branch (IDB) of the Ministry of Agriculture organized a series of three workshops, in which District Irrigation Engineers updated the irrigation and drainage databases for their districts. They were also given basic training in GIS and provided with topographic maps, which they used to estimate the respective GPS (Global Positioning System) of each irrigation and drainage scheme in the district. These updated data were then compiled into Excel spreadsheets and converted to ArcView files to prepare maps of irrigation and drainage data. ArcView, one of the leading software products for desktop GIS and mapping, enables the user to visualize, explore, query and analyze data geographically. The IDB considered this software to be useful in the current project, as well as for long-term day-to-day management of the irrigation and drainage database, and it will be used by a wide cross section of the IDB personnel.

With the GIS database it is now possible to easily extract scheme-, district- and national-level information. Further, it is now possible to analyze water use in each river basin. The database includes 2,210 documented smallholder irrigation and drainage schemes in Kenya, covering an area of 56,603 hectares. About 196,864 farmers are involved in irrigation and drainage, with 81 percent involved in irrigation alone. The Tana river basin has the highest concentration of irrigation schemes, while drainage schemes are concentrated in the Lake Victoria basin. The database obtained is accurate within reasonable limits but much work is needed to improve it. More needs to be done to make the GIS functional and self-sustaining. Among these activities are the need to train staff at IDB in GIS, as well as the District Irrigation Engineers, and to equip them with modern GIS hardware and software, to enable them to update the data accurately.





## Summary—Paper No. 4

### **Preliminary Evaluation of Irrigation Development in Kenya**

*Stephen N. Ngigi, University of Nairobi*

Three workshops held with irrigation officials between November 1999 and February 2000, aimed at identifying issues that required in-depth investigation to analyze factors affecting smallholder irrigation development in Kenya. This paper documents the current trends in irrigation development for each province. Additionally, issues that emerged from the three workshops pertaining to irrigation development are discussed, focusing on problems, current status and recommended courses of action.

Trends in irrigation development in the districts are not uniform—in some districts the area under irrigation has increased while in others it is stagnant or even decreasing. Why these differences exist is not clear; an in-depth evaluation would enable the irrigation community in Kenya to learn from the successes and failures.

Among the capacity-building suggestions was the idea to build the capacity of farmers and District Irrigation Engineers through exchange visits and training at demonstration centers. It was also suggested to build the capacity and morale of irrigation officials through financial incentives for providing good services to water users. Financial and economic measures included encouraging farmers to obtain credit and build their capacity to manage their financial resources. Credit institutions should recognize farmers' seasonal needs for money and provide a reasonable grace period for repayments. Appropriate marketing facilities need to be established.

Policy recommendations included the idea that the government should adopt viable policy changes and keep all stakeholders informed about changes in government policies. The government should encourage commercial farming and diversification of agricultural production and address the issues of land tenure and access to water in some arid and semiarid land (ASAL) districts. The government should also appoint a body charged with the resolution of conflicts arising from competition for water and develop suitable guidelines for the resolution of such conflicts.

Technical recommendations stressed the need to improve on-farm water management and incorporate water-saving technologies and improve knowledge of precision irrigation systems. Farmers should be encouraged to improve on-farm innovations through experimentation. Drainage in western Kenya should be further developed and a work plan for the installation of drainage systems should be prepared. Irrigation officials should be trained on GIS applications to make use of databases being established. These officials should then examine current and future irrigation water demands in the context of watershed management.

Among institutional measures is the need to strengthen farmer organizations (FOs) and water user associations (WUAs) through training in decision making, project/scheme management, leadership skills, financial management, record keeping and enforcement of bylaws. All training should encourage participation by both men and women. Bottom-up,

participatory and integrated approaches in which the government participates as an equal stakeholder should be promoted. An Irrigation and Drainage Working Group composed of all stakeholders should be established that will both monitor progress and advise with respect to irrigation and drainage development in Kenya.

Under the theme “evaluation and research” it was recommended that sample districts should be selected for in-depth studies whose results should result in a strategy to raise income for farmers’ irrigation enterprises. The objectives of future studies should include analysis of matching water demands and supplies, quantifying production per unit of water, measuring water efficiency in different kinds of irrigation schemes and measuring water-use efficiency at the river-basin level, where irrigation and other water uses are considered in an integrated approach.

These recommendations clearly show that irrigation development cannot be left to the government alone but that all the stakeholders should collaborate in addressing the challenges, opportunities and constraints of irrigation development in Kenya.

## Summary—Paper No. 5

### **Water Scarcity and Conflicts: A Case Study of the Upper Ewaso Ng'iro North Basin**

*Francis N. Gichuki, University of Nairobi*

Competition and conflicts over water resources increase as the demand for scarce water resources increases. Conflicts are further aggravated by social inequity, economic marginalization and poverty. All these factors force resource-poor land and water users to overexploit soil, water and forestry resources, which often results in negative environmental impacts. Ironically, water is the most manageable of the natural resources, as it can be moved great distances from the points of origin to points of use and can be stored to be used at the most opportune time or in the most convenient amounts.

The paper examines the Upper Ewaso Ng'iro North river basin, which is located northwest of Mount Kenya. An analysis of river flows from 1960 shows a clear trend of decreasing dry-season flows without a corresponding decline in rainfall. An analysis of surface water and groundwater potential and domestic, livestock and irrigation water requirements projected to the year 2010 shows that the basin will experience serious water constraints. The densely populated area at the foot of slopes and on the Laikipia plateau, where population pressure has been increasing and where there is a high irrigation potential, will experience the highest water deficit.

High levels of water abstraction in the upper reaches of the Ewaso Ng'iro have been blamed for decreasing water availability in the lower reaches. Overabstraction in the upper reaches of the river has been taking place since the introduction of irrigated agriculture in the area but it has increased at an exponential rate since 1984 when production of horticultural crops for the export market became very profitable. There is a higher level of abstraction in the upper reaches, mainly due to the hydraulic advantage, suitability for irrigation development, access to the market and the settlement density.

Conflicts over the use of water resources result from competition for water resources, mainly during the dry season, and the presence of deep-seated latent conflicts. Conflicts associated with water scarcity are attributed to overabstraction of water in the upper reaches, land use and management-induced changes in flow regimes resulting in decreased low flows, water pollution and to prolonged drought conditions. Latent conflicts are attributed to inequalities inherent in social, cultural, racial, economic and political disparities among the stakeholders. Latent conflicts include perceived inequitable access to water and land resources, economic and political elites supporting commercial interests over and above those of the local groups, and longstanding ethnic, cultural, racial, political and economic differences. Latent conflicts are generally dormant until "reawakened" by scarcity and/or inequitable allocation of the scarce resource, mainly during periods of drought.

Under conditions of conflict, efficient water management is crucial to maximize benefits and spread them as widely as possible. An important prerequisite for this is the availability of data to understand and interpret the hydrological characteristics of the area.

Although the government has played a key role in promoting sustainable water management through the water-resources management policy, legislation and institutional roles, due to lack of political will and adequate budgetary provision for implementing policies and enforcing legislation, it has become evident that water stakeholders will have to play a key role in creating the enabling framework for action. Involvement of stakeholders, capacity building, a sound information base and mechanisms for conflict resolution are the key elements for addressing water scarcity and associated conflicts in the basin.

## Summary—Paper No. 6

### **Links between Land Management, Sedimentation, Nutrient Flows and Smallholder Irrigation in the Lake Victoria Basin**

*Chin Ong and Frederick Oregó, International Center for Research in Agroforestry*

The Lake Victoria basin supports an estimated 27 million people who produce an annual gross economic product of about US\$3–4 billion. The lake catchment economy is principally an agricultural one with a number of cash crops, fisheries and subsistence agriculture. The quality of the physical environment is crucial in maintaining and increasing the living standards of the growing population.

Wetlands play an important role in the Lake Victoria ecosystem. They absorb and slow downstream flow, filter and remove sediments and degrade pollutants. They are highly productive systems with a high nutrient-fixing ability as well as serving as important habitats for wildlife. The conversion of wetlands for agriculture has elicited considerable controversy: agronomists regard wetlands as potential areas for the much-needed crop production while ecologists argue to conserve the ecology and biodiversity of wetlands.

The last 20 years have witnessed a high rate of conversion of wetlands into irrigated agricultural land. In one basin alone, the Nyando river basin in western Kenya, which drains into Lake Victoria, over 6,500 hectares of wetland have been converted to irrigation. However, a sizeable portion of the reclaimed area is rapidly reverting to swamps due to a multitude of reasons, the most prominent being sedimentation. The long-term future of these irrigation schemes is bleak unless the high sediment load in the Nyando river is controlled. The challenge for wetland utilization is to increase agricultural land in such a way that ecological functions are maintained. The first step is to identify how upland management and wetland reclamation for development impact on the performance of irrigation schemes and on the water quality in rivers and lakes.

The paper documents three cases that highlight the impact of sedimentation problems in the basin on irrigation schemes and their potential solutions. In the Gem-Rae case, the scheme was abandoned barely 12 years after its inception because of the heavy sediment load deposited in the canals. Although the southwest Kano irrigation scheme is still operational, the long-term future is bleak unless the high sediment load in the Nyando river is controlled. The Kore case provides a small but promising example of the benefit of a well-designed irrigation scheme, which utilizes the natural filtering capacity of the wetlands. Most of the sediment in the river feeding the Kore system is trapped as the water filters through the swamp, thus significantly reducing the amount of sediment reaching the scheme. The Kore irrigation scheme shows that the sustainability of irrigation schemes developed in sediment-loaded river basins can be enhanced if the irrigation water is filtered through swamps and not abstracted directly from the river.

Generally, agricultural development (and particularly irrigated agriculture) may bring about an increase in water pollution due to increased land use accompanied by high application of fertilizers and the use of other chemicals. The actual source of the nutrients in the basin needs

to be investigated. There is no documentary evidence to suggest an excessive use of inorganic fertilizers and chemicals in the Nyando river basin.

Information from the field indicates that fertilizer provided to the tenant farmers in the government-managed schemes is not actually used within these schemes but rather that most of it is sold to smallholder farmers outside these schemes. The actual point sources and the contribution of nutrient pollution from agricultural lands to the lake should be investigated and quantified.

## Summary—Paper No. 7

### **The Impact of Water Scarcity on Pastoral Systems: Experience from the 1995–97 Drought and the 1997–98 El Niño Rains in the Greater Horn of Africa**

*Jean Ndikumana, Animal Agriculture Research Network Coordinator,  
International Livestock Research Institute*

A survey was conducted in southern Ethiopia, northern and southern Kenya, northern, northwestern and central Tanzania and central/southwestern Uganda on coping mechanisms of pastoralists and agro-pastoralists during the 1995–97 drought and the 1997–98 El Niño rains. The purpose of the study was to obtain baseline information about what pastoralists did to sustain themselves and their livestock during the critical periods of drought and flood. The survey focused mainly on the assessment of the effects of the crises on livestock dynamics and welfare of the household and the coping mechanisms adopted by pastoralists to mitigate the effects of these crises.

Trekking for water of consumable quality for livestock is one of the key determinants of pastoral movement and migration. The study found that pastoralists used a number of different livestock water sources across varying climatic zones: boreholes (established by the use of drilling equipment), hand-dug wells, dug-streambeds (excavated dry or sluggish streambeds to encourage seepage of water), ponds, concrete tanks on the ground, concrete tanks above the ground and reservoirs/dams. During the El Niño rains, ponds were the dominantly used water sources while, during the drought, hand-dug wells were the most common water sources. Pastoralists resorted to digging streambeds and the use of boreholes, measures that indicated scarcity of water. Boreholes at some locations carry a mandatory fee and are, thus, avoided until other sources are exhausted.

Mobility is an inherent strategy of pastoralists to optimize production from a heterogeneous landscape under precarious climatic conditions. The search for forage as well as for water for human and livestock consumption triggers mobility and migration, which were shown to be intensified by drought.

The quality of a water source was a key determinant of the trekking distance. Poor-quality and contaminated sources that had water unacceptable to livestock were abandoned in preference to better-quality sources located further away. Trekking long distances to watering points reduced the effective grazing time available to livestock, and in some zones, the frequency of watering of livestock was also reduced to once every 3 to 4 days. Restricted watering is a strategy that allows livestock to cover greater radii in search of grazing sites, reduces herding- and watering-labor and increases the efficiency of water use.

The distance trekked to livestock water sources tripled with the drought, from an average of 5.9 km pre-drought to 15.8 km, on average, across zones, with pure pastoralists trekking a further distances than agro-pastoralists. Distances to grazing sites increased from an average of 5.5 km to 20.4 km across zones, with pure pastoralists trekking further distances. Emergency

water sources and grazing sites were used but they were not necessarily farther away from the homestead compared to primary grazing sources. In some areas, swamplands/marshlands that were closer than the primary grazing sources were used in emergency times. At other times, pastoralists avoided these areas as much as possible because they were disease-infested areas. In general, the distances trekked to water were further than to the grazing sites. The distances to emergency water sources and grazing sites were furthest for the most arid zones of southern Ethiopia and northern Kenya.



## Summary—Paper No. 8

### **Smallholder Management of Irrigation in Kenya**

*Wouter Scheltema, Consultant*

For many years, the main impulse for changes in the furrow and wild-flooding methods of traditional Kenyan irrigators came from outside influences. The first influence was from Arab traders along the coast with the introduction of rice cultivation. Later, during the late nineteenth century, laborers brought from the Indian subcontinent for the construction of the Ugandan railway started irrigation schemes for growing Asian vegetables. Specialization in Asian vegetables continues to date, although now it is in the hands of Kenyan farmers. The third impulse came during the Second World War when the colonial government required food for the British army. The government promoted the production of vegetables around Karatina in the Nyeri district and constructed some simple diversion structures that are still in use. After independence in 1963, the Government of Kenya promoted rice production through centrally managed top-down schemes with tenant farmers.

In the late eighties, the Ministry of Agriculture realized the problems encountered in promoting smallholder irrigation and introduced guidelines that evolved to a participatory planning method, in which the farmer's participation was managed through a stepwise process. In the early nineties, donor interest in smallholder irrigation in Kenya lessened and it was foreseen that farmers had to make their own investments. Agreements were made with several financial institutions but performance was poor and, today, many schemes face problems in even generating adequate funds for O&M.

Today, smallholder irrigation in Kenya consists mainly of group schemes with gravity water supply in which high-value cash crops or rice crops are grown. Rice cultivation is restricted to the heavy clay soils (black-cotton soils), which are less suitable for the more profitable high-value crops. The Government of Kenya sees irrigation as a means of dealing effectively with problems of food security; however, irrigation schemes are economically viable only if high-value cash crops are produced. High-value crops may range from those that can be stored for short periods of time, such as onion, sweet potato and pepper to more perishable crops such as tomato, spinach and Asian vegetables. These crops are grown most profitably in the dry season to take advantage of off-season prices, when there is no competition from rain-fed producing areas.

Smallholder irrigated horticulture is a highly diversified cropping system. A wide range of crops is grown in the irrigated plot with 2–3 crops grown per year. Outside of group schemes, smallholder irrigation generally occupies only a small part of the farmer's holding on which rain-fed agriculture and livestock production are practiced as well.

Farmers in each scheme are organized into a Water User Association (WUA) registered with the Ministry of Water Resources by virtue of application for a water permit through the district water bailiff. The experience in Kenya is that the management of an irrigation scheme should be the responsibility of a separate organization that deals with the "water" aspects only. The few combinations of a WUA and a cooperative society dealing with input supply

and marketing have all collapsed. Marketing of irrigated crops is a major problem in Kenya. Farmers invariably complain of unfair farm-gate prices, although studies show a reasonable profit margin in areas where sufficient competition between middlemen has occurred. A major problem in making agreements between groups of farmers and middlemen or exporters is the unreliability of agreements by both partners.

In horticultural crop production, at least half of the fieldwork is done by women and in rice production this work is even more. Women-headed households constitute a large number of farm families and include those headed by widows, unmarried women, and where the husbands work outside the farm community. Often, the latter amounts to one-third or one-half of the households in the area. To assure information transfer, gender-balanced representation is needed in WUAs.

## Summary—Paper No. 9

### **From Government- to Farmer-Managed Smallholder Rice Schemes: The Case of the Mwea Rice Irrigation Scheme**

*Charity Kabutha, Consultant and Clifford M. Mutero, International Water Management Institute and International Center of Insect Physiology and Ecology*

After nearly 40 years of highly structured top-down management, radical changes have occurred at the Mwea Rice Irrigation Scheme in central Kenya. The farmers took over the running of the scheme at the end of 1998 and have been running it since, albeit with difficulties.

There are hundreds of areas of conflicts between the National Irrigation Board (NIB) and the farmers. Restrictions on rice sales and low producer prices, high costs of irrigation-related services, unreasonable restrictions on farmers, a land tenure system that treated farmers as tenants and the absence of the voice of the farmers within management were key tinder for igniting the conflict. After a heightening of confrontations between the farmers and the NIB, the farmers took over the running of the scheme. This study traces the historical events fomenting the radical change and analyzes the current management system, its challenges and opportunities to forge ahead.

There are divided assessments on the nature of this change. According to the farmers, this change is final and there is no going back. The use of the term “divorce” to illustrate this change is enough to conclude the position of the farmers. The government, while acknowledging the change, still sees its role in the scheme and considers itself the de jure manager. In some ways the government is right since it still controls assets essential to the operation of the scheme but, in fact literally, the keys to the main control structures of the system were handed over to the farmers’ group.

In addition to discussions with farmers, the study team held discussions with the NIB field managers on a variety of issues. Discussing the history of Mwea and the events that had led to the takeover of the management of the scheme, the managers acknowledged the undemocratic mode of management that, although perhaps viewed as necessary at the beginning, failed to change with the times. A senior manager indicated that discussions on possible changes had been conducted within the NIB for quite sometime but these changes had never been adopted.

Since the farmer takeover, the Mwea Rice Multipurpose Cooperative Society has managed the irrigation scheme with, and on behalf of, the farmers. The association, established in 1964, had a difficult history as reflected in successive splits and mergers. Although the farmers were talked to attributed this instability to interference by the NIB and had high hopes of greater stability, there was evidence of other challenges in the form of poor management, accountability, etc. The current management of the society, which has been in office for 2 years, has made efforts to keep afloat amidst daunting technical, financial and infrastructural challenges. Its management appears more democratic than in earlier times. According to the farmers interviewed, transparency is central to the survival of the society. To ensure this transparency, farmers

have put in place mechanisms including a “shadow management committee” approach, which checks and evaluates the work of the official central committee.

Innovation and flexibility have helped the society in the face of constraints. For example, the society has leased small rice mills from independent contractors and has farmed out services such as rotation to supplement its 20-tractor capacity. The management system is apparently more democratic and sensitive to the plight of farmers, and prices paid to farmers have almost doubled while opportunities for farmers and the people of Mwea have increased (farmers can sell the bulk of their paddy to independent rice millers, thus creating a new category of beneficiaries within the scheme). In addition, farmers have opened up new land for rice on their own initiative. On the whole, the farmers interviewed have reported that the socioeconomic status of the entire area had improved.

While certain things have worked well, the cooperative society knows that there are daunting technical and financial challenges ahead of them. The human capacity is overstretched. The farmers have limited equipment and machinery and virtually no capital for operations. Banks are unwilling to advance loans in view of uncertainties of the scheme. Certain key functions, such as water management and research, have not been established. The society has limited milling capacity and lacks critical machinery and equipment, such as excavators that are meant to keep the canals free of weeds and silt. Private-sector milling has come in but it does not produce quality rice, which can compete with imported rice. Clearly, this analysis underlines the unfinished business at Mwea. There are issues to be resolved between the government and the farmers but, meantime, the farmer cooperative urgently needs injection of capital to successfully keep the scheme functional.

## Summary—Paper No. 10

### **Health Impact Assessment of Increased Irrigation in the Tana River Basin, Kenya**

*Clifford M. Mutero, International Water Management Institute, and International Center of Insect Physiology and Ecology*

Agricultural policies, products and processes are major determinants of people's health. More than two-thirds of the people in developing countries derive their livelihood from agriculture. Most working time is spent in agriculture, and most income is spent on food. The health of most people is inextricably linked with the agriculture sector and agriculture dominates life in rural areas.

This paper presents a prospective health impact assessment (HIA) of increased smallholder irrigation in the Upper and Lower Tana river areas in Kenya. The purpose of the assessment is to identify opportunities for improvement of human health and enhancement of household incomes through better agro-ecosystem management.

Up to now, malaria has been the leading cause of morbidity and attendance at outpatient health facilities not only in the study area but also generally in most of Kenya. More than 5 million cases of malaria are reported in the country annually, with hospitalization due to malaria surpassing only that due to AIDS since 1998. The two communicable diseases likely to be most impacted on by an increase in smallholder irrigation are malaria and schistosomiasis. The risk assessment places emphasis on these two diseases as well as other hazards such as malnutrition.

The assessment concludes that increased irrigation will likely improve the food production systems along the length of the Tana river basin and, in turn, maintain good nutrition among the resident communities. However, based on community, environmental and institutional risk factors, the assessment suggests that there will be an increase in the risk of malaria among communities living both in the Upper and the Lower Tana areas in the event of an expansion in smallholder irrigation for rice and other crops. The creation of mosquito-breeding habitats due to small-scale irrigation activities in the Upper Tana area will lead to an increase in malaria-vector populations. Immigrants from malarious areas will provide a parasite reservoir that could result in malaria transmission taking place for most of the year. The vector habitat will similarly expand in the downstream area due to human activity, particularly related to trans-humance and enhanced smallholder irrigation. The assessment also concludes that there will be an increase in intestinal schistosomiasis in the Upper Tana and Lower Tana areas in case of increased irrigation activities.

For malaria and schistosomiasis, a community-based health education program for promoting awareness about the diseases and available control options should be implemented at the start of expansion of irrigation activities in a given area. In the case of malaria, screening the eaves and windows of houses with mosquito-proof mesh wire could be a cost-effective

method of reducing mosquito-person contact. Both the government and the NGOs should support communities in setting up sustainable systems for the provision of insecticide-treated mosquito nets and antimalarial drugs. These measures are especially important if increased mortality is to be avoided among the high-risk groups including pregnant women and children below 5 years. As regards schistosomiasis, swimming (by children) in infected water is considered to be the most important factor for continuing or increasing disease transmission. It would be of benefit if villages along the Tana river are provided with snail-free bathing areas. These should be centrally sited, concrete-lined and protected from snail colonization. Latrine provision is also an essential element in the control of schistosomiasis, thus there is a need for the promotion of improved and long-lasting latrines.

## Summary—Paper No. 11

### **Integrated Pest Management Issues in Irrigated Agriculture: Current Initiatives and Future Needs to Promote Adoption by Smallholder Farmers in Eastern Africa**

*S. Sithanantham, A. A. Seif, J. Ssenyonga, C. Matoka and C. Mutero,  
International Centre of Insect Physiology and Ecology*

Irrigated agriculture is characterized by intensive land use and substantial use of external inputs. Intensive year-round production of crops in the tropics, particularly of vegetables under irrigation, induces the continuous presence and build-up of pests and diseases, which often reach epidemic proportions. Growers are prompted to increasingly lean to pesticides to protect their crops, which leads to environmental pollution, build-up of resistance in pests and diseases, destruction of beneficial arthropods, build-up of hitherto minor pests and unacceptable levels of pesticide residues in vegetable produce. Integrated Pest Management (IPM) is an approach that seeks to minimize and rationalize the use of chemical pesticides as well as to promote the use of safer alternatives to pesticides (e.g., biocontrol, cultural practices). Since intensive cultivation of crops is a feature of irrigated agriculture and, often, external inputs figure prominently in these cropping systems, IPM becomes more a need than an option in such systems.

Assessing the IPM needs of smallholder farmers in irrigation project areas can provide a basis for appropriate initiatives for training and information dissemination. A survey was undertaken to understand the IPM practices and issues in irrigated agriculture in the Mwea division, the Kirinyaga district, Kenya. Fifty farmers growing rice and vegetable crops were selected randomly from within the five sections of the Mwea irrigation scheme and adjacent villages. The status of farmers' knowledge and the use of different pest-management practices were found to differ sharply between the two farming systems. Rice farmers appear to have limited experience in using pesticides, and their knowledge of pests, diseases and associated problems is lower than that of farmers in the open (non-scheme) multi-crop agricultural systems. It is also evident that scheme farmers grew mainly one crop, rice, which has fewer pest problems. Intensity of pest control in vegetable-growing systems is high and a number of chemical pesticides are in use. It appears that pesticide application regimes and intensity are high, especially during the dry season. Vegetable farmers appear to have a higher extent of knowledge of the adverse effects of pesticides than rice farmers. It is impressive to find that farmers are articulate on the harmful effects of pesticides, on beneficial insects and on other organisms. However, restricting the use of pesticides seems to be limited to export crops, apparently in response to strict regulations imposed by importing countries.

The use of indigenous pest-control practices seems to be constrained by several factors: laboriousness, lack of appropriate dosage recommendations and even prejudice against them. Supportive research is required to evaluate the efficacy and cost-effectiveness of these practices. What is more important is to create awareness among the farmers that they need to

consider alternative approaches due to the reported declining effectiveness of chemical pesticides. IPM programs need to be developed that better link research and extension with a wider menu of IPM options for key pests as well as for effective awareness-building programs to take IPM to the grass-roots level.



# Summary—Paper No. 12

## **Economic and Social Impacts of Commercialization of Smallholder Irrigation**

*H. Ade Freeman and Said N. Silim, International Crops Research Institute  
for the Semi-Arid Tropics, Nairobi, Kenya*

Increases in smallholder commercial irrigation and adoption of new irrigation technologies in Kenya provide new opportunities for increasing agricultural productivity and incomes especially in semiarid areas. Irrigation reduces the risk of crop production and, therefore, provides greater incentives to increase input use, intensify crop production and diversify into higher-valued crops. The resulting increases in marketable surplus and commercial activities generate increased income for farmers. Yet, as smallholder commercial irrigation expands, issues relating to access to water among competing user groups, enterprise profitability and access to markets take on added importance because they directly impact the size and distribution of benefits accruing to stakeholders.

A study was conducted in two semiarid districts, Makueni and central Meru, districts of eastern Kenya having an estimated population of 1.3 million. Production of horticultural crops is an important economic activity in both districts with smallholder farmers producing most of these crops. In central Meru an estimated 2,009 hectares were under horticultural crops in 1998, an increase of 69 percent over the area in 1991. Production data show a 174-percent increase over total production in 1991. In the Makueni district, horticultural production appears to be declining, with 277 hectares under irrigation.

Data available for central Meru suggest that the number of irrigation projects has increased 45 percent in 10 years. However, these values have underestimated the growth of smallholder irrigation because many new projects have not been recorded. Smallholder irrigators concentrate on a wide range of high-valued horticultural crops, mostly vegetable and fruit crops, for year-round sale in the domestic and export markets. A wide range of high-valued horticultural crops are grown including Asian vegetables (such as brinjal, ravaya, chili and okra, and karella, guar, dudhi, turia, curry leaves, patra and saragua); vegetables for the domestic and export market (tomato, kale, onion, spinach and baby corn) and fruits (mango, papaw, custard apple and citrus).

There were several companies involved in marketing of export crops. In central Meru it was estimated that the number of companies involved in marketing rose from 13 in 1997 to 20 in 1999. For domestic crops, most farmers sold their crops at the farm gate to rural traders within the village or to outsiders. Some traders entered into informal contracts with farmers before the crop was harvested. Interlinked transactions are very common with company agents providing farmers with seeds, chemicals, advice on planting, application of chemicals, grading, sorting and packing.

Data indicate that smallholder production of horticultural crops is a highly profitable enterprise when compared to alternative investment options that farmers can undertake in other

crops. For example, the gross margin for the most profitable enterprise is about 400 percent higher than that for the competing maize crop.

Smallholder farmers are facing a number of constraints. Infrastructure constraints include inaccessible roads and lack of power, electricity and market facilities. Input constraints include unavailability of quality seeds and lack of trading capital. There are high levels of post-harvest losses. Low and dispersed productions result in a lack of economies of scale leading to high cost of assembly. High rejection rates are encountered at both the farm level and the company warehouses because products do not meet market standards.

There are high levels of price and market uncertainty. Information on market trends for scheduling of production to meet market needs is unreliable. Farmers and other market intermediaries were not aware of important factors like price, marketing, grades and standard information further up in the marketing chain.

The authors' research suggests that for smallholders to survive in the highly competitive and exacting world of horticultural exports, programs need to be developed that make marketing more efficient. Lowering high transaction costs arising from the high costs of information, negotiation and contract enforcement should be priorities in programs to promote smallholder agriculture in the rural areas of Kenya.

## Summary—Paper No. 13

### **Water Policy and Law in a Water-Scarce Country: Implications for Smallholder Irrigation in Kenya**

*Chris Huggins, African Center for Technology Studies*

Customary systems of water management in Kenya have assured that each individual is provided with water by virtue of affiliation with a specific tribe or clan. Water use has been regulated and controlled by the political leaders of each community (e.g., chiefs, elders, clan leaders). Water sources that have been readily accessible, such as bodies of surface water, have been generally regulated by the leaders of the community for the benefit and use of the community as a whole.

The present legal regime for water management in Kenya has evolved from English common law in which water has been classified as a public good. There has been, therefore, no legal possession of water in an absolute sense, only rights of use dependent upon physical access to water. Those who have had no riparian rights had no other rights over the resources, which meant that citizens, in their capacity as members of the public, had no right to complain over misuse or overexploitation of water resources.

This legal framework evolved from a water-abundant country and did not place stringent controls on water use or encourage the use of water for “the greater good” or for the most economically efficient use. Clearly, this framework is not appropriate for a water-scarce country such as Kenya.

This paper provides an overview of the legal and policy framework of the water resources of Kenya and examines the key national issues affecting water allocation for smallholder irrigation. These issues include a) the decentralization of water-management responsibilities, b) the contrasting strategies of supply-oriented water development and demand management, and c) institutional coordination and institutional adaptation. The paper also asks whether the legal framework is reflected by actual practice. Interview data collected at smallholder irrigation schemes located in the Taveta division, Taita-Taveta district, provide an insight into the ways in which the laws and policies are enforced and the ways in which they are perceived by the farmers. The paper concludes by outlining the key challenges to be faced in the future, and options and opportunities for effective water management under situations of water scarcity.

The findings indicate that the Ministry in charge of water affairs has, in the past, been highly centralized, resulting in a broad gap between planners/engineers and consumers. This distance has discouraged long-term programs for capacity building of the community and other initiatives to entrust communities with responsibility for monitoring and managing the quality and quantity of water. At the local level, uncertainty by government institutions over the acreage of land, currently being irrigated, is symptomatic of the lack of government capability, largely due to financial constraints, to perform basic services in rural areas. The difficulties in enforcing the bylaws on the use of water in irrigation schemes are exacerbated by frequent episodes of theft of water by members of irrigation committees and even by the local chiefs, leading to a

general breakdown of law and order. Localized variation in the availability of water should be acknowledged in water-management plans, and current or potential water scarcity should be made apparent to all stakeholders.

# Summary—Paper No. 14

## **Relevance of Kenyan Irrigation Experience to Eastern and Southern Africa**

*N. Hatibu, H. F. Mahoo and O.B. Mzirai,  
Sokoine University of Agriculture, Morogo, Tanzania*

The trend of free-market economic systems in the region has given rise to the claim that irrigation should be demand-driven. This means that commercial requirements should guide farmers, communities and even countries to choose the type and extent of irrigation most suitable for their circumstances and businesses. This is a radical step, given the recent history of irrigation development in sub-Saharan Africa, where governments have used irrigation as a tool for achieving social goals with little concern for economic considerations. Justifications for irrigation development have included attempts to achieve food self-sufficiency and security, creation of employment, establishment of settlements and boosting of foreign exchange earnings. The governments have enacted policies, which stipulated by how much and by what means irrigation would be developed. Irrigation was supply-driven rather than demand-driven and the authors of this paper claim that failures, such as the Bura irrigation scheme in Kenya, are consequences of this policy.

However, large public-irrigation schemes that made news by failing miserably are not the whole story of irrigation in the region. There are examples, in all the countries reviewed, of very successful large and small commercial irrigation schemes. Therefore, the review of the changing face of irrigation in the region provides an opportunity to learn from both failures and successes so as to properly guide the ongoing privatization and commercialization of the irrigation subsector in the region.

The authors compare and assess the relevance of the Kenyan irrigation experience to eastern and southern Africa with examples from Sudan, Ethiopia, Zimbabwe, Mozambique and Tanzania, which provide differing frameworks on which to extrapolate the experience from Kenya.

The authors conclude that the database on irrigation is inadequate and is of low quality, and that governments need to place greater priority on efforts to improve data.

Rainfall is the major source of irrigation water but its availability and distribution are highly skewed throughout sub-Saharan Africa. Lack of water storage exacerbates the situation, leading to the perception that there is a scarcity of water.

Many of the problems associated with ownership and accessibility to water stem from the fact that water is viewed as a public good and free access to water is considered as a human right. Similarly, landownership and tenure in all the countries are not conducive to the commercial irrigation subsector.

Technologies for achieving high levels of water control are available but these need to be promoted vigorously and should be supported by research, training and extension services.

In recent years, the ownership and management of irrigation projects have been in transition to privatization, while parallel to this, private investment in irrigation is gaining, with emphasis on high-value export crops, such as vegetables and flowers.

Irrigation requires a substantial amount of capital investment. Consequently, farmers, as investors in irrigation, require assured markets and prices to make a profit. Contrary to this, many farmers in the reviewed countries face marketing problems, which are partly due to lack of research and training in marketing.

Stakeholders in water resources include farmers, input suppliers, actors from other sectors and even nations. In all the countries reviewed, conflicts among different stakeholders exist over the distribution and sharing of water resources. To ensure equity, therefore, it is necessary to develop catchment/basin approaches to water resources development.

The role of governments is still not very well defined and not uniform in the region. In countries like Sudan, the government controls aspects of irrigation from policy making to actual production. On the other hand in Zimbabwe, for example, most irrigation is outside the direct control of the government. The philosophy of market economy dictates that governments should refrain from prescriptive policies but should rather provide basic enabling conditions for commercially sustainable development of the irrigation subsector. This requires that governments ensure policies, legislation and strategies are in line with the promotion of effective and productive utilization of water resources for agriculture.

## Part 1

### Setting the Context

# Review of Irrigation Development in Kenya

*Stephen N. Ngigi<sup>1</sup>*

## INTRODUCTION

### Background

The land area of Kenya is 582,646 km<sup>2</sup>, 17 percent of which is classified as medium to high potential land with more than 700 mm of rainfall per year, which is suitable for rain-fed agriculture. The remaining land is classified as arid and semiarid lands (ASALs) and cannot reliably support rain-fed agriculture unless other technologies, such as irrigation and water harvesting, are used to augment water for crop production.

The government recognizes the important role that the agriculture sector plays as the backbone of Kenya's economy. The sector (including the agro-based industries), contributes approximately 55 percent of the Gross Domestic Product (GDP), provides about 80 percent of employment, accounts for 60 percent of exports and generates about 45 percent of government revenue (Ragwa et al. 1998).

Supporting the rapidly increasing population and ensuring the economic growth in the dwindling landholdings of high- to medium-potential lands will require the use of technologies, which will ensure the intensification of production in such potential lands and the opening of new lands in the ASAL areas. This is possible only with the use of irrigation technologies.

Food security is the major output of irrigation development activities. However, this cannot be achieved without sustainable water resources management. The new thinking currently gaining ground is the integration of irrigation water management within the broader context of integrated water resources management. This is understandable because irrigation is a major user of water. In Kenya, irrigation uses over 69 percent of the limited developed water resources (Torori et al. 1995) and despite this high water use, the performance of irrigation projects has not been impressive.

Food shortages are a recurrent problem, which cannot be solved through rain-fed agricultural production alone, without irrigation development. In Kenya, food insecurity continues to loom, not to mention the existing water crisis. As demand for food increases, more and more water will continue to be used in an attempt to alleviate persistent food shortages. Available water resources are diminishing, leading to conflicts over water uses and among water users. The increasing demand for water for the domestic and industrial sectors is expected to continue. This means that the water use by the agriculture sector must be decreased to 33 percent by the year 2025 (Seckler et al. 1998). This calls for more efficient use of water in

---

<sup>1</sup>Department of Agricultural Engineering, University of Nairobi, P.O. Box 30197, Nairobi.



irrigation. The irrigation efficiency, which was estimated at 27 percent in 1990, should increase to 54 percent to reduce the water withdrawals in irrigation by the year 2025 (Seckler et al. 1998).

The situation is even gloomier in the ASALs, where water scarcity is the main constraint to agricultural development. The problems posed by inadequate water supply are aggravated by population growth, environmental degradation, competition over the use of limited natural resources and increasing water demand. There is a need to develop immediate, practical and sustainable solutions to address the twin problems of inadequate water and food insecurity (Ngigi 1999). The government has realized this need and a number of government and donor interventions have been undertaken, especially in the vast drylands, though with limited success.

## **Role of Irrigation**

For the last two decades, agricultural production has not been able to keep pace with the increasing population. To address this challenge, Kenya must seek ways to improve and stabilize agricultural production to cater to the needs of its increasing population. The biggest potential for increasing agricultural production lies in the development of the ASALs, especially through the development of irrigation and water-harvesting technologies. For instance, if 50 percent of the irrigation potential—of which only less than 10 percent is now exploited—is exploited, Kenya would not only be self-sufficient in food but also be a producer and exporter of agricultural products.

## **Contribution of Irrigation to the National Economy**

Irrigation and rain-fed agriculture are complementary and not mutually exclusive. Irrigation can assist in agricultural diversification, enhance food self-sufficiency, increase rural incomes, generate foreign exchange and provide employment opportunities when and where water is a constraint. The major contributions of irrigation to the national economy are food security, employment creation, settlements and foreign exchange.

### ***Food Security***

In the ASALs, smallholder irrigation schemes have been used to supplement fodder. However, contributions to food security are more pronounced in group-based irrigation and National Irrigation Board (NIB) schemes, where rice is the main crop, accounting for 90 percent of rice produced in the country (Kimani and Otieno 1992).

### ***Employment Creation***

Irrigation is labor-intensive and is able to generate 730 person-days of labor per irrigated hectare. Hence, irrigation makes a substantial contribution to job creation.

### ***Settlements***

Irrigation's contribution to settlements is largely associated with NIB schemes (Mwea, Hola and Perkerra), which have settled unemployed and landless people.

## ***Foreign Exchange***

Irrigation has provided opportunities for growing crops that earn foreign exchange or are substitutes for imports. Of significant importance is the growth of the horticultural industry in the private commercial sector.

## **Categorization of Irrigation Development in Kenya**

### ***Public Irrigation Schemes***

This category includes the settlement schemes managed by the NIB and the Bura irrigation scheme run by the Ministry of Agriculture. These schemes are based on a tenant-farmer system where each tenant is generally allocated 0.4–1.0 hectare. The other schemes in this category are managed by regional authorities and are operated as commercial estates, e.g., the Yala irrigation scheme under the Lake Basin Development Authority (LBDA), the Sigor irrigation scheme under the Kerio Valley Development Authority (KVDA), and the Kibwezi and Tana deltas, under the Tana and Athi River Development Authority (TARDA).

### ***Smallholder Irrigation Schemes***

These schemes can be further grouped into two types.

- Schemes where the irrigation infrastructure and water distribution systems are operated and maintained by a water undertaker. Examples of this type are the Yatta Furrow and Njoro Kubwa Furrow where the Ministry-in-charge of water resources is the water undertaker. Another scheme is the Southwest Kano irrigation scheme where an NGO called Smallholder Irrigation Scheme Organization (SISO) is the water undertaker.
- Schemes where the Water User Association (WUA) has full responsibility for operating and maintaining the irrigation infrastructure and for distributing the water to all its members. Most of the schemes supported by the Irrigation and Drainage Branch of the Ministry of Agriculture fall into this subcategory, for example, Mitunguu, Kibirigwi, Eldume, Ishiara, Kwa Kyai and Ngaare Ndare.

### ***Private Commercial Farms***

These are commercial farms or estates that produce high-value crops, such as floricultural and horticultural crops, mainly for the export market. Often, these farms are highly specialized in their production of technologies, such as drip, sprinkler and even center pivots. Most of these farms are found in the Athi river area, Naivasha, parts of Central province, around Nanyuki and in the peri-urban areas of Nairobi. Currently, horticultural production is spreading rapidly in the Central province, Rift valley (mainly Nakuru districts and districts neighboring the Eldoret airport) and the Mt. Kenya region.

## EVOLUTION OF IRRIGATION DEVELOPMENT

### Historical Development of Irrigation

Irrigation is an age-old technology involving the artificial application of water to supplement rainfall for the purpose of crop production. In Kenya, there is evidence that local communities, especially Marakwet, the Ilchamus (Jemp Maasais), the Turkana and the Pokomo, may have practiced some form of irrigation for the last 500 years (Njokah 1992). Formal irrigation started between 1901 and 1905 during the construction of the Kenya-Uganda railway around Kibwezi and Makindu. Large-scale irrigation commenced in the mid-1950s with the development of Mwea-Tebere, Hola and Perkerra irrigation schemes.

The evolution of irrigation development can be categorized by the way they were initiated and/or the period when they were constructed, as follows:

- *Indigenous irrigation schemes* found in Marakwet, West Pokot, Tana river and Baringo districts.
- *Slave-labor irrigation schemes*, which were started in the middle of the nineteenth century, along the river valleys in the Coast province around Kipini, Malindi, Shimon and Vanga, mainly using Arab-owned slave labor. The present Vanga cluster of irrigation schemes is an example of this type of irrigation development. These and other similar schemes collapsed after the abolition of slavery towards the end of the nineteenth century.
- *Uganda railway irrigation schemes*, which were established during the construction of the Uganda railway between 1901 and 1905. Some irrigation schemes were established around Makindu and Kibwezi to produce vegetables for the Asian workers. The Indians who had some experience started these clusters each up to 30 hectares along the railway line. Some have continued specializing in Asian vegetables to date (see paper by Freeman and Silim).
- *Irrigation schemes*, which were established during the Second World War (1939–1945). The need to feed the British troops in East Africa during this war was another event that triggered irrigation development. This period marked the establishment of irrigation in the Kano plains, Taita Taveta, Rumuruti and Karatina.

### *Irrigation Development during Pre-Independence*

Planned irrigation development started after the Second World War, around 1946, when the African Land Development Unit (ALDEV) embarked on a broad agricultural rehabilitation program in “native reserves” whose basic aim was to contain African agitation for land occupied by the European settlers (Ragwa et al.1998). This program included irrigation development, among other approaches. The onset of the Mau Mau uprising and agitation for independence gave an added impetus to this program. ALDEV, the implementing agency, initiated a number of irrigation schemes using the pre-independence Mau Mau detainees as free labor. Between

1950 and 1960, detainee labor was used to construct irrigation infrastructure in Mwea, Hola and Perkerra irrigation schemes.

### ***Irrigation Development during Post-Independence***

The efforts of the Government of Kenya in irrigation development after independence focused mainly on establishing large-scale tenant-based irrigation schemes. The Ministry of Agriculture took over the management of the three initial schemes namely Mwea, Hola and Perkerra. In July 1966, the NIB was enacted with the mandate to develop, improve and manage national irrigation schemes in Kenya. By the mid-1970s, another three schemes were constructed: Ahero, Bunyala and West Kano irrigation schemes. This brought the number of schemes under NIB to six. The Bura irrigation scheme was constructed between 1978 and 1983. This scheme, which is also under the central management but under the Ministry of Agriculture, is no longer functional.

Apart from the centrally managed schemes, in the late sixties a number of small-scale irrigation schemes were developed using UNDP/FAO funds in arid zones, especially in Turkana, Isiolo and Garissa districts. Examples of these schemes include Katilu, Merti and Galfasa. These schemes were developed with the objective of settling nomadic people affected by occasional droughts, thus providing them with an alternative livelihood. Irrigated agriculture was expected to augment food security and thus reduce the burden on relief food supplies. In the early 1970s, irrigation activities in Taveta and Lower Tana were also started either by the government or by the NGOs, also with the aim of supplementing food supplies in these areas.

Research findings demonstrated that, in the mid-sixties, coffee irrigation was profitable and hence a number of coffee estates in the Central province were initiated with sprinkler irrigation systems. Similar commercial irrigation activities were later started with the view to expanding horticultural production around Thika (for pineapples) and in Naivasha (for vegetables).

### **Institutional Development**

In January 1977, the Small-Scale Irrigation Development Project (SSIDP) was established under an agreement for technical cooperation between the Governments of Kenya and the Netherlands. The main objective of the SSIDP was twofold: to promote and develop a participatory model of small-scale irrigation and to establish a national institutional framework for the planning and implementation of smallholder irrigation and drainage programs within the Ministry of Agriculture.

Through the SSIDP, the Small-Scale Irrigation Unit (SSIU) was created in the Ministry of Agriculture and was renamed the Irrigation and Drainage Branch (IDB) in 1978. The IDB established Provincial Irrigation Units (PIUs), which in the mid-1980s were decentralized to District Irrigation Units (DIUs) conforming to the government's policy of the District Focus for Rural Development.

## **Shift in Irrigation Policy**

The centrally managed schemes with a top-down management approach have proven unsustainable, one reason for which is the reliance on government subsidies. The farmers have not been comfortable with this approach due to overexploitation and lack of control over the marketing of their produce. The intended benefit of improving the living standards, to say the least, has not been realized—the tenants continued to live in “ambient” poverty—until they could withstand it no longer. The recent scenario in Mwea (details presented in the paper by Mutero and Kabutha) tells a lot about the deteriorating relationship between the government and the farmers. This case clearly indicates that there is a need to change the approach of managing large-scale NIB irrigation schemes if sustainability is to be forthcoming.

Nevertheless, there has been a shift of policy in the development in the last 20 years (details in paper by Huggins). The emphasis has been to facilitate the development of smallholder irrigation projects, especially in the ASALs, through the IDB. In this approach, community participation in planning, implementation and O&M has been emphasized. However, this approach also seems to have some problems, especially with regard to scheme management. This could be attributed to some degree of overdependence on government subsidies although such schemes were expected to be sustainable because they are owned, operated and maintained by the farmers. Overreliance on the government has led to the abandonment of a number of schemes, especially after the El Niño rains, which damaged many irrigation structures. While the government is now reconsidering its policy towards smallholder irrigation, farmers are now realizing that they must assume management responsibility for their irrigation schemes.

### ***Commercialization of Irrigation***

The government has realized that group-based irrigation investment is costly and that its limited resources have been overstretched. In recent irrigation development in Kenya, there has been a deliberate effort by the government to promote greater beneficiary participation through cost sharing, cost recovery and gradual liberalization and privatization in an effort to commercialize the agriculture sector. The emphasis now and in the future is to have less government intervention and pursue a balanced policy that incorporates both public and private sectors and beneficiary participation to build self-sustaining systems. In this structure, the government will concentrate on performing the core or strategic functions such as policy formulation and coordination of development efforts. This philosophy is further articulated in the proposed Agricultural Sector Investment Programme (ASIP) that recognizes a) the private, nongovernmental and governmental sectors as partners in development and b) the need to adopt an integrated approach to agricultural development.

The guidelines presented in the appendix were revised in 1993 to incorporate an item on farmers’ contributions as a prerequisite for sustainable irrigation development (Ragwa et al. 1998). Due to the dwindling availability of funds for investment in irrigation development from both the government and the donor community, and the need to impart a sense of ownership of the schemes by the beneficiaries, the guidelines also explored various avenues for mobilization of financial resources for irrigation development. This led to the concept of cost sharing, cost recovery, revolving funds for infrastructure-development loans and allocation of grants for specific issues. The paper by Freeman and Silim presents details on economic and social impacts of commercialization.

### ***Cost Sharing***

Cost sharing is recommended for rice schemes, which are expected to have moderate gross margins. The farmers are expected to cofinance the development of infrastructures of rice schemes with the government, donors and NGOs. Farmers' contributions take various forms, e.g., contribution in cash, provision of unskilled casual labor and provision of land for drains and access roads. Once the projects are implemented, the O&M functions are entirely the responsibility of the beneficiaries—the farmers.

### ***Cost Recovery***

In 1993, the cost-sharing policy was taken a step further to full cost recovery for horticultural schemes. Farmers can fetch high returns from these schemes, which are commercially oriented. Under this policy, development agencies are expected to provide investment capital in the form of credit, which is recoverable once the scheme is in production. The beneficiaries are expected to take up the O&M functions and ensure that the credit is paid back to the lending agency.

### ***Revolving Funds for Irrigation Infrastructure Loans***

The guidelines recommend that investment capital for smallholder irrigation development should be provided through a revolving fund to facilitate reuse of the funds after repayment to finance other projects.

### ***Grants for Food-Based Irrigation Schemes***

Food-based irrigation schemes are located in marginal areas (ASALs), which are food-deficit areas. These schemes cannot be justified if economic viability criteria alone are applied. However, to ensure food security in these areas, projects have been initiated where the development of irrigation infrastructure has been financed through grants by the government, NGOs or donors. These schemes also require subsidization of O&M costs for over a long period of time before they are able to become self-sustaining.

## **TRENDS IN IRRIGATION DEVELOPMENT**

### **Irrigation Potential**

There are two basic reasons why the irrigation potential of any country should be estimated. First, it provides a base for the formulation of strategies for irrigation development and, second, it gives a benchmark for monitoring progress within the irrigation sector. Several factors need to be considered when estimating the irrigation potential that include, inter alia, water resources, availability of suitable land, cropping patterns and the irrigation technologies to be used.

The following studies have been carried out to assess the irrigation potential in Kenya: MoWD 1980; World Bank 1987; IDB 1990; Kiragu, 1992 and JICA 1992. The estimated irrigation potential and breakdown for the five drainage basins are presented in table 1. The disparity in the estimated potential could be attributed to factors considered and the assumptions made in each of the studies.

Table 1. Estimated irrigation potential (ha) in Kenya.

Drainage Basin	MoWD (1980)	World Bank (1987)	IDB (1990)	JICA (1992)
Tana	205,500	90,000	100,000	
Athi	40,000	49,500	40,000	
Lake Victoria	200,000	57,400	145,000	
Kerio Valley	64,000	31,200	85,000	
Ewaso Ng'iro	30,000	15,700	20,000	
Total	539,500	244,700	390,000	471,860

Due to technological developments, which are generally more water-efficient, the potential irrigable area is expected to be increased progressively. It is not surprising that some districts like Nakuru have reported an increase in irrigated area that is double the estimated irrigation potential. On the other hand, high rates of population growth have induced demands for water in the other sectors and is evidence that water scarcity is growing.

It is ironic that we are unable to exploit irrigation potential substantially, mainly due to water scarcity when only 5.4 percent of the potential ( $14 * 10^9 \text{m}^3/\text{year}$ ) surface-water resources is exploited (Chebwek 2000). The groundwater exploitation is also meager and only 9.4 percent ( $57.2 * 10^6 \text{m}^3/\text{year}$ ) of available groundwater is exploited.

## Irrigation Development

Kenya has a relatively limited irrigation tradition and the majority of existing irrigated areas were developed between 1960 and 1980. Since then, the rate of irrigation development has unfortunately declined as shown in table 2. Despite the irrigation growth since 1975, the area under irrigation is far less than the potential irrigable area estimated between 244,700 and 539,500 hectares (table 1 above) in Kenya. Tables 1 and 2 show that the area under irrigation is between 15.6 and 34.5 percent of the irrigation potential. Nevertheless, irrigation has been making a substantial contribution towards national agricultural goals: food self-sufficiency, raising of rural incomes and generating employment. Currently, there is a notable contribution of irrigation to the horticultural export industry—the third highest foreign exchange earner of the country.

Table 2 shows a tremendous increase in the area under small-scale irrigation in the period 1975–90. This could be attributed to the attention given to this sector by the government and the donors, as smallholders are perceived to spread the benefits more evenly. There has been an immense growth of smallholder and commercial, large-scale irrigation development in Kenya between 1975 and 1990. However, the growth of large government-managed schemes has not been significant. Before 1990, irrigation development, as reflected by the area under irrigation, was on an upward trend. The economy by then was favorable to all sectors. Indeed, between 1983 and 1990, donor support boosted the development and sustenance of smallholder irrigation schemes. The trend in irrigation development in Kenya shown in table 2 can be presented as shown in figure 1.

Table 2. Irrigation development in Kenya (1975–98).

Category	Area under Irrigation (ha)					
	1975	1983	1990	1992	1995	1998
Commercial private irrigation	10,000	17,000	22,979	23,280	37,000	40,700
Large-scale irrigation (NIB)	8,500	10,000	10,325	9,020	9,000	9,000
Small-scale irrigation	2,400	3,500	18,907	20,490	33,000	34,650
Total	20,900	30,500	51,401	52,790	79,000	84,350

Sources: Heyer 1976; IDB 1990; Ragwa et al. 1998; and Ogombe 2000.

Note: Small-scale irrigation development includes schemes developed by the IDB, NGOs, and individual farmers or groups of farmers. The recent increase under this category could be attributed mainly to individual efforts, i.e., small-scale households.

Figure 1. Trend in irrigation development in Kenya.

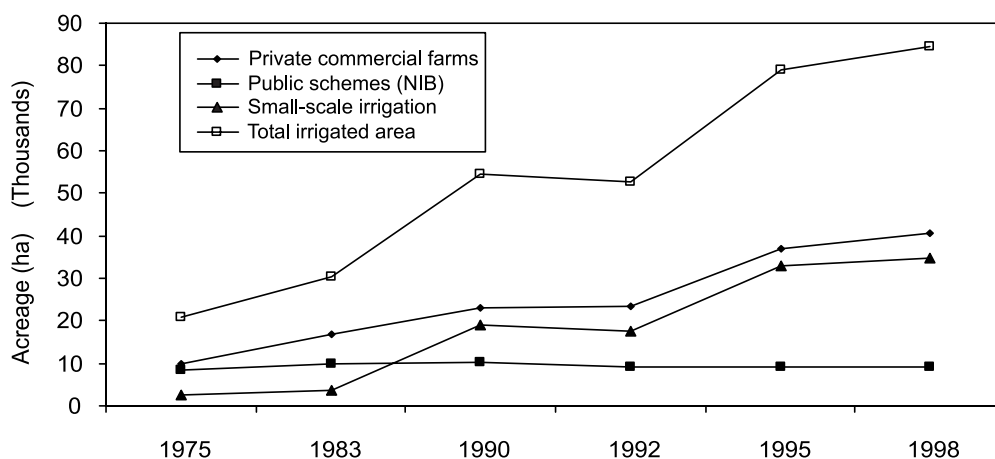

It is evident that despite the initial positive trends, the rate of development of government-supported large- and small-scale irrigation schemes has been declining. Poor water management and ensuing environmental problems, such as waterlogging and salinization have led to a decline in agricultural productivity of some irrigation schemes. Consequently, the outputs from irrigation development have not been commensurate with the massive government efforts and donor support in this sector. It is also notable, on the other hand, that private individual and NGO-supported small-scale irrigation development activities have progressively increased.

Despite the decline in the rate of irrigation development, there are a number of promising small-scale irrigation technologies with high water-use efficiency being promoted in Kenya. They include, but are not limited to, low-head drip-irrigation systems, ApproTEC treadle/pedal “super money-maker” pumps, Jua Kali low-head sprinklers, small basins, etc. (Ngigi 1999). A number of these technologies seem to be gaining more attention and popularity in Kenya. Increases in the acreage resulting from these technologies may not be captured in the national statistics. Details on new irrigation technologies in Kenya are presented in the paper by Sijali and Okuma.



## Factors Affecting Irrigation Development

### *High Cost of Irrigation Development*

Irrigation investment requires a relatively high capital investment for infrastructural development when compared to rain-fed agriculture. This capital is not within the reach of many smallholder farmers. The costs are further escalated, if horticultural production is considered, which is highly capital-, labor- and input-intensive. The costs of pump-fed irrigation schemes are, depending on the technologies used, higher than those of gravity-fed schemes. The average cost of smallholder irrigation development (Ragwa et al. 1998) is summarized in table 3.

*Table 3. Average cost of smallholder irrigation development.*

Type of the System	Average Cost (Ksh) per ha
Gravity-fed open canal conveyance and distribution	80,000
Pump-fed open canal conveyance and distribution	150,000
Gravity-fed open canal conveyance, piped distribution	150,000
Gravity-fed piped conveyance and distribution	200,000
Pump-fed piped conveyance and distribution	250,000

### *Farmers' Access to Credit Facilities*

The majority of farmers, especially those in the smallholder category, lack financial resources to invest in irrigation activities. To access credit, farmers are required to provide collateral by commercial financial institutions. Because of this, coupled with the fact that the financial institutions find it risky, expensive and cumbersome to administer such credit, many smallholder farmers are precluded from obtaining such credit facilities. Inadequate access to credit has, to a great deal, slowed down the development of smallholder irrigation development in Kenya.

### *Lack of Clear Policy on Irrigation Development*

Irrigation development in Kenya has been constrained by the lack of a national policy that would create an enabling and conducive environment for all actors.

### *Coordination of Various Stakeholders in Irrigation Development*

There are various stakeholders who are directly engaged in irrigation development in Kenya. Although these players could contribute significantly to the development of irrigation, implementing the institutional framework to effectively coordinate and rationalize the use of the limited resources is a daunting task. This has resulted in duplication and overlap of activities, misappropriation of limited resources, inefficiencies and conflict of interests.

### ***Water Availability and Utilization Efficiency***

The spatial and temporal distribution of water resources in Kenya is skewed so that it is expensive to undertake irrigation development in some areas due to the long distance that water has to be conveyed. This, coupled with the use of inefficient technologies and poor on-farm water management, implies that the pressure on scarce, easily exploitable water resources will continue to deter development, especially in the arid and semiarid areas.

### ***Support Services for Irrigation Development***

In many areas with high potential for irrigation development there is inadequate infrastructure such as access roads, marketing outlets, electricity, extension services, etc. These factors have contributed to the declining pace of irrigation development in some areas in Kenya.

### ***Land Tenure System***

Title deeds of lands are a prerequisite to the development of irrigation as they provide security for obtaining loans for investment in irrigation development. In many areas where there is potential for irrigation development, especially in the ASALs, land adjudication to facilitate issuance of land title deeds has either not been done or is incomplete. This has been a serious setback to irrigation development in some areas because farmers cannot access credit and have no incentive to invest due to insecurity of land tenure.

Landownership continues to affect water management, especially in the ASALs where land rights are governed as trust lands. Lack of adequate land tenure has drastically affected irrigation development in these areas. Torori et al. (1995) argued that any efforts arrived at improving water resources management must be based on the prevailing land-tenure system, as this provides the context and defines rights to water.

### ***Marketing of Fresh Horticultural Produce***

Marketing of fresh horticultural produce has been a persistent problem for smallholder farmers. This could be attributed to reasons such as the inaccessibility of some schemes due to bad roads, coupled with flooding the market with produce due to lack of diversification and uncontrolled production. Middlemen are also accused of manipulating the market and exploiting the poor farmers. The lack of an organized marketing system, seasonal fluctuation in demand, quality concerns and perishability of produce aggravate this situation.

### **Water Allocation for Future Irrigation**

In view of continuing water scarcity and competition among users and uses, there is a need to seek measures that will foster sustainable increases in the productivity of water used in agriculture through better management of irrigation and water-basin systems. Being the biggest water user, irrigation requires special attention. If Kenya is to realize its industrialization goals by 2020, then more water is required for industrial development, not to mention the ever-increasing domestic water demands. Hence, there is a need to evaluate irrigation development with the aim of achieving sustainable water-resources management. The preliminary evaluation identified issues and opportunities for better management of water for irrigation and improved food production.

However, the answer to the question “how to reduce irrigation water use from the current 70 percent to 33 percent, as recommended by Seckler et al. (1998),” still remains elusive. Conflicts over water resources are real in Kenya. The current drought has brought to the fore the water-crisis time bomb. For instance, in the North Ewaso Ng’iro river basin, the government was forced to ban all irrigation activities to ensure that there was water for downstream users (details in paper by Gichuki). To enforce the ban, the Administration Police has been called in, especially where downstream users have decided to march upstream and destroy all irrigation intake structures. In response to the 1999–2000 drought, the Ministry of Natural Resources and Environment (Department of Water Development) convened a national meeting of all the major water users—mainly large-scale commercial farmers—to seek ways of addressing the increasing water scarcity. Unfortunately, despite the high irrigation demand, other uses are accorded more priority under the law (Water Act, chap. 372).

## **EVALUATION OF IRRIGATION DEVELOPMENT**

### **Need for Evaluation**

Past efforts, such as the development of large- and small-scale irrigation projects through the NIB and the IDB, had initially shown a positive trend in alleviating poverty and improving food security. Irrigation projects, which had been initially successful, have, in many cases, declined in productivity and, in some cases, they have been abandoned. There is a need to evaluate past and current irrigation development in Kenya to map out sustainable future strategies. Participation by farmers in such a process will be crucial, as farmers have developed and are continuing to develop sustainable coping mechanisms for food security and water scarcity, which if understood and improved could be the long-awaited solution.

There are a number of innovative approaches being developed and adopted by farmers to enhance food security in Kenya. These approaches are, unlike the conventional irrigation systems, inexpensive and easily manageable and, in spite of some negative past experiences, some technologies are showing promising results and increasing adoption rates by small-scale farmers. These include low-head drip irrigation technologies, such as the bucket and drum-drip irrigation system, developed by Chapin Watermatics, among others, which are being promoted by the Kenya Agricultural Research Institute (KARI) and other stakeholders in Kenya (for more details see paper by Sijali and Okumu). Other recent technologies that may require further evaluation are low-head “Jua Kali” sprinklers, small basins and ApproTEC’s treadle/pedal “super money-maker” pumps, to mention a few.

These new technologies have not been evaluated to ascertain their technical and socioeconomic performance under the local conditions. The possibilities of adapting other high-level technologies, such as greenhouse farming systems to small-scale users, for example, need to be explored. The promise of new technologies needs to be evaluated to identify constraints and opportunities for future strategies to address water scarcity and the ensuing food insecurity.

There are various reasons for the irrigation potential to have been unrealized despite the persistent food shortage. Some of these issues need to be critically addressed in light of declining irrigation development. There is a clear indication that something must have gone wrong along the way in the development of irrigation projects in Kenya (Ngigi 1999). This calls for a need to evaluate the genesis of the current situation with a view to identifying successes, failures, challenges, opportunities and constraints. The evaluation needs to point out what went wrong and formulate possible remedies and future strategies. In addition, the evaluation process also needs to be geared towards collecting data necessary to enhance the development and management of water resources.

## **Concept of Evaluation**

The objectives of an evaluation should be to understand the factors affecting the viability of small-scale irrigation development in Kenya with the aim to:

- evaluate the trend of irrigation development in Kenya,
- identify and analyze underlying socioeconomic factors,
- identify challenges and opportunities for improving small-scale irrigation schemes,
- review gender roles in irrigation development,
- review health and environmental issues related to irrigation evolution,
- determine governance issues such as water rights, access to and use of water, water abstraction permits,
- identify promising technologies, especially water-efficient irrigation technologies, to be promoted, and
- contribute to the technical, economic and social evolution of irrigation development in Kenya.

The evaluation outlined is a participatory learning process, which involves all key actors and critical issues that affect irrigation development in Kenya. This process recognizes the fact that the solutions to declining irrigation development could be identified by looking back at where we started, the current situation and where we want to be in the future. Comparative evaluation of various irrigation schemes vis-à-vis different technologies, water management, socioeconomic factors, crop production and marketing systems, institutional arrangements, sociocultural and gender perspectives, etc., will form the basis of a focused evaluation process. Evaluation and monitoring should be a continuous process if sustainable irrigation development is to be realized.

An effective evaluation should focus on the trends of various technologies, social organizations and related training and research activities and their overall impact on small-scale irrigation development in Kenya. Identification and evaluation of the numerous innovative developments in, and application of, small-scale irrigation technologies will provide the basis

for the development of appropriate guidelines for future irrigation development. Identification of successful developments will also provide a strong basis for the development of participatory technology. The evaluation should not focus on a particular technology against its technical specifications but rather on the experiences of users in the application of the techniques (IWMI 1999).

The proposed evaluation concept assumes that irrigation schemes are at various levels of development and we need to understand the factors that have led to those different levels. For simplicity, three levels (low, middle and high) are to be considered. They are evaluated against no irrigation development on the lower level and sustainable irrigation development on the higher level. The sustainable irrigation-development level may vary from one scheme to another and, hence, it could be either higher or lower than the higher level of development. The shift from one level to another has important learning lessons necessary for understanding the genesis of irrigation development. The time taken to pass from one level to another also varies from scheme to scheme, depending on a number of factors that will also be important for the evaluation process. The evaluation process is graphically presented (figure 2) below:

Figure 2. Basic evaluation concept.

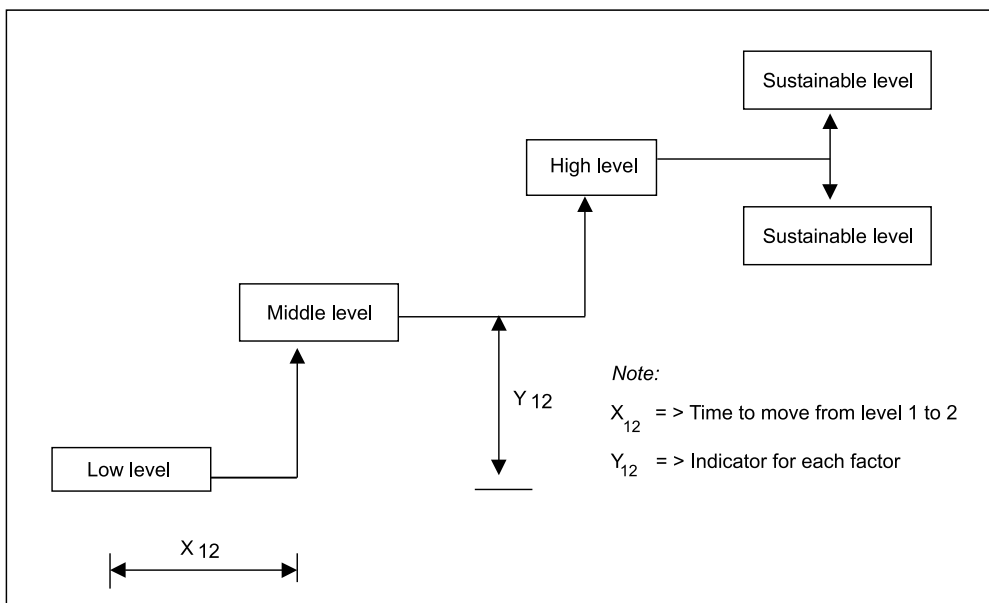

In this figure, the y axis represents different development levels of various parameters, factors or indicators, whilst the x axis represents the time taken from one development level to another. The sustainable level represents the targeted or anticipated development level for a scheme. Therefore, a critical evaluation of different irrigation schemes, say three, at different levels of development, say low, middle and high, may reveal the required effort required to move from one level to another or why an irrigation scheme is at a certain level. Such an evaluation will identify the development or advancement paths of different schemes and factors that determine the path. This will be important in planning future strategies, which aim at developing a scheme to a higher level. The evaluation will also identify training needs for farmers, irrigation committees or extension staff based on experiences of the others, with the aim of enhancing the development process. The concept can also be used to evaluate the performance of a cross section of projects over a certain time period.

## **Database Development**

For effective monitoring and evaluation of irrigation development and performance of irrigation projects, a reliable and updated database is a prerequisite. The advent of Geographical Information Systems (GIS) is making database development and updating easier. Although GIS is just starting to be widely utilized in Kenya, the basic data files are becoming more freely available and the technology has advanced so that it is more user friendly (Mati 2000). GIS can now be used with the minimum assistance of specialists. GIS can display data in a very quick and visual manner. Therefore, GIS should be available at the national level to assist in monitoring irrigation development (see paper by Mati).

## **CONCLUSIONS AND WAY FORWARD**

### **Conclusions**

The rapid changes in the political economy of Kenya are having a direct impact on the nature of irrigation and the benefits that accrue from investing in modern irrigation technologies. The rapid pace of these changes means that there is an opportunity to use Kenya as an example of similar changes in a number of countries in eastern and southern Africa (Blank 2000). The three most important changes are the following:

- The capacity of the government to manage large-scale surface systems has rapidly deteriorated. In the Mwea irrigation system, which forms over 60 percent of the large-scale systems operated by the NIB, farmers are in the process of taking over its responsibilities and operate and maintain the systems by themselves, despite the lack of any formal management structure or federated water user organization (see paper by Mutero and Kabutha). In many irrigation areas, rules for water allocation and distribution imposed for many years are now in abeyance and new

rules and operational strategies are needed to help farmers effectively manage water into the future.

- Commercialization of smallholder irrigation has enabled some individuals to move away from the irrigation of traditional food grain crops and enter the high-valued vegetable and fruit market (see paper by Freeman and Silim). This has been accomplished, in part, through smallholder contacts with marketing agents and expansion of markets for such crops as tomato, French bean and Asiatic vegetables.
- New technologies are being rapidly introduced and adopted widely by irrigators. These include motorized pumps, manually operated treadle-type pumps, low-head drip-irrigation kits and locally manufactured sprinkler and drip systems. Because some of these technologies enable them to lift water, farmers, many of whom are women, can access water sources previously unavailable to them, and they can use water much more effectively on small plots so that potentially they can expand the area they can cultivate.

These changes are likely to result in improved utilization of the scarce water resources of Kenya and increase the incomes of those who are able to take advantage of the new technologies. However, there are some cautionary lessons that need to be learned from current experiences in Kenya that have a wider regional importance, particularly those that address issues of water rights, environmental degradation, poverty alleviation and equity. According to Blank 2000, the most critical of these cautionary lessons appear to be the following:

- Inadequate capacity of the government to regulate and control access to water resources because much of the new development relies on small pumping and water-lifting devices owned and operated by individuals. This may lead to basin-level problems of access to water, and intensify the adverse impacts of irrigation associated with higher input use such as conflicts over water, equity concerns, groundwater depletion and undesirable environmental effects (see paper by Gichuki).
- Traditional community water rights may be overridden by individual-based irrigation development resulting in a realignment of access to water to a more entrepreneurial class of farmer.
- Reduced access to water by the very poor and disadvantaged members of the community, including women, who cannot afford the initial investments, albeit small in terms of potential benefits, in new irrigation technology.
- An urgent need to facilitate transfer arrangements in systems where the government has traditionally had management responsibility but can no longer provide these services due to the lack of finance and manpower so that tail-end and other less-influential farmers do not lose their existing rights of access to water.
- Rising concerns about environmental issues such as the relationship between irrigation in wetlands (see paper by Chin and Orego).

A review of irrigation development reveals that Kenya is already experiencing all of these issues and is struggling to find ways in which access to, and exploitation of, water resources for irrigation can be undertaken in such a manner as to support increased agricultural production, maintain an acceptable level of equity of access to water, maintain ecologically sensitive land uses and continue to reduce poverty through improved production of food and cash crops.

## **Way Forward**

The importance of evaluation of irrigation development in Kenya cannot be overemphasized. The evaluation will assist in updating the database and identifying opportunities and constraints to improve the productivity of irrigation activities. Therefore, an evaluation of irrigation development is aimed at identifying the following:

- future strategies—which way—for irrigation development
- what has gone wrong—past mistakes—leading to decline in irrigation development
- means to increase the productivity of water
- water-scarce and constrained irrigation schemes and river basins
- conflicts among irrigators and other water users
- what needs to be done to increase food production
- research and training needs to enhance irrigation development
- promising technologies for small-scale irrigation development
- adaptive strategies and farmers' innovations for addressing various constraints
- documenting recent trends in irrigation development recommendations to policy makers, donors and other stakeholders, etc.



## **Guidelines on Smallholder Irrigation Projects in Rural Development**

These guidelines were formulated in 1986, mainly to impress upon district planners and agricultural officers on the concept of smallholder irrigation and the important role it can play in rural development within the context of district focus for rural development. The guidelines identified the basic developmental phases of an irrigation project, i.e., scheme identification, investigation, design, implementation and O&M. Monitoring and evaluation were also identified as important activities for measuring achievements against objectives and targets. The guidelines emphasized the importance of farmer participation in all these stages for the success and sustainability of the scheme.

### ***Guidelines on Farmers' Participation***

In an effort to mobilize development resources and ensure sustainable irrigation development, the Irrigation and Drainage Branch (IDB) developed guidelines in 1991 to ensure full beneficiary participation in all phases of project development. The IDB recognized that local people have a wealth of knowledge, skills and organizational abilities that have evolved over a period of time for the purpose of managing the local resources and adaptation to the prevailing physical and socioeconomic environment.

### ***Concept of Participatory Development***

Participatory development in smallholder irrigation development is encouraged, based on the experience that participation of farmers in the management of irrigation systems results in better performance with respect to water use, production and O&M. This approach entails the involvement of farmers to empower them to take the leading role with respect to decision making in planning operations, and the management of their resources and the scheme. Participation of farmers presents an opportunity to improve their capability and strengthen their organizations and institutions that are prerequisites to sustainable development.

### ***Concept of Sustainability Development***

The concept of sustainable development is also introduced in the guidelines. Sustainability concept, when viewed within the context of smallholder irrigation development generally refers to the long-term ability of the beneficiaries to operate and maintain their schemes profitably with little or no external intervention other than the normal extension services.

Therefore, sustainable smallholder irrigation development entails the devising of a technical, social and economic production system, which guarantees that the farmers' goals of increased levels of income, increased levels of food security in the household, employment opportunities and general improvement of their standards of living are sustained through effective management of their irrigation systems.

## Literature Cited

- Blank, H. G. 2000. *The changing face of irrigation in Kenya: Opportunities for anticipating change in eastern and southern Africa*. A SWIM Concept Paper. Nairobi: International Water Management Institute.
- Chebwek, N. J. 2000. The role of the MENR in irrigation development in Kenya. In *Proceedings of the 3<sup>rd</sup> Regional Workshop on Evaluation of Smallholder Irrigation and Drainage Development in Kenya, 22–25 February 2000*, 8–9. Kenya: Kisumu.
- Heyer, J. 1976. Achievements, problems and prospects in the agricultural sector. In *Agricultural development in Kenya: An economic assessment*, ed. J. Heyer, J. K. Maitha and W. M. Senga. Nairobi: Oxford University Press.
- IDB (Irrigation and Drainage Branch). 1990. *Irrigation atlas of Kenya*. Nairobi, Kenya: Ministry of Agriculture.
- IWMI (International Water Management Institute). 1999. *Draft work plan for research program supported by the African Development Bank*. Colombo, Sri Lanka.
- JICA (Japan International Cooperation Agency). 1992. *The national water master plan (NWMP II), main report*. Nairobi, Kenya: JICA and MoWD.
- Kimani, J. K.; and J. O. Otieno, eds. 1992. *Which way irrigation? Proceeding of a National Workshop, 26-29 May, 1992*. Nairobi: Irrigation and Drainage Branch.
- Kiragu, D. K. 1992. Assessment of irrigation potential in Kenya. In *Which way irrigation? Proceeding of a National Workshop, 26–29 May, 1992*, ed. J. K. Kimani and J. O. Otieno, 20–25. Nyeri, Kenya.
- Mati, B. M. 2000. Use of GIS techniques in smallholder irrigation management and planning. In *The changing face of irrigation in Kenya: Opportunities for anticipating change in eastern and southern Africa*.
- MoWD (Ministry of Water Development). 1980. *The national water master plan (NWMP I)*. Nairobi, Kenya.
- Ngigi, S. N. 1999. Evaluation of irrigation research and development activities in Kenya: Towards promoting small-scale irrigation technologies. Draft Project proposal for IWMI.
- Njokah, J. J. 1992. Irrigation research. In *Which way irrigation? Proceeding of a National Workshop, 26–29 May, 1992*, ed. J. K. Kimani and J. O. Otieno, 82–86. Nyeri, Kenya.

- Ogombe, I. J. O. 2000. Potential and actual irrigated agriculture in Kenya: Implications for investment strategy. Paper presented during panel discussions on Investment Opportunities and Challenges in Irrigated Agriculture for National and Household Food Security, 17 July, 2000 at Grand Regency Hotel, Nairobi.
- Ragwa, P. K.; N. R. Kamau; and E. D. Mbatia. 1998. Irrigation and Drainage Branch position. Paper presented during the Workshop on Promotion of Sustainable Smallholder Irrigation Development in Kenya, 16–20 November, 1998. Kenya: Embu.
- Seckler, D.; D. Molden; and R. Barker. 1998. *Water scarcity in the twenty-first century*. IWMI Water Brief. Colombo, Sri Lanka: International Water Management Institute.
- Torori, C. O.; A. O. Mumma; and A. Field-Juma. 1995. *Governance of water resources in Kenya*. Ecopolicy Series No. 8. Nairobi: ACTS Press.
- World Bank. 1987. *The study and options and investment priorities in Irrigation Development Consultancy Report conducted by Ensoconsult*. Nairobi, Kenya: World Bank.

# New Irrigation Technologies

*Isaya V. Sijali and Rose A. Okumu<sup>1</sup>*

## **Abstract**

Lack of appropriate and affordable irrigation technologies geared towards poor farmers on small plots is a major constraint to the spread of irrigation in Kenya and elsewhere in sub-Saharan Africa. Most irrigation equipment used in conventional pressurised irrigation systems in Kenya is imported and costly. As equipment suppliers are few, farmers have to pay higher prices for equipment. To address these problems, therefore, appropriate technologies need to be identified and adapted to suit smallholder farmers. These technologies need to be a) appropriate, simple and, if possible, equipment should be made using local materials and skills, and b) affordable and have the potential to earn high returns on investment.

Small-scale drip irrigation systems and human-powered pedal pumps emerged in Kenya in the late 1980s. They have continued to gain popularity in the 1990s and are making a significant impact on rural communities. The potential for these systems is still unexploited (only less than 2% has been exploited) because of many factors, including rampant poverty and lack of information, but there is an upward trend in their adoption.

There is a need for continued development and adaptation of the technologies and programs to teach farmers how to use them, as has happened in Asia.

## **Introduction**

In Kenya, as in many parts of sub-Saharan Africa, agriculture is the mainstay of the livelihood of the citizens. The country enjoys a variety of climates and soils but less than 20 percent of the land area is considered arable under rain-fed condition. The remaining 80 percent, classified as arid and semiarid lands (ASALs) experiences water shortage, which is a major constraint to agricultural production. Due to population pressure in the high- and medium-potential areas, people whose livelihoods traditionally depended on subsistence farming, moved to the ASALs and intensively cultivated them. However, this was not sustainable without external inputs such as water and nutrients. Irrigation was identified as the key to agricultural development in the marginal areas and the Government of Kenya initiated a number of large-scale irrigation schemes. The large schemes did not perform to expectations and depended on the government for subsidies for their O&M. This reliance could not last long and the policy slowly changed with the government shifting its focus to the development of smallholder group-based schemes and to irrigation development by individual holders. Although the schemes faced problems

---

<sup>1</sup>The authors are attached to the Irrigation and Drainage Research Section, National Agricultural Research Laboratories, Kenya Agricultural Research Institute, P.O. Box 14733, Nairobi. Email: Lisguest@kari.org

such as availability of inputs and marketing of produce, their performance has generally been better than that of the large schemes.

Low water use efficiency, soil salinity, insect-pest damage, plant diseases and poor crop husbandry negatively influence crop production under irrigated farming. Smallholder farmers tend to look for irrigation technologies that they can understand and afford to buy. Such technologies are found, for example, in traditional manual irrigation where water is hand-carried over a distance to be splashed on vegetable plots. The emergence of small-scale irrigation technologies that poor farmers could understand, invest in, and use to grow crops for food and cash was an important change in the irrigation sector in Kenya. The two main technologies, which have been adopted by Kenyan farmers, are the small-scale drip irrigation systems and treadle pumps. These technologies were designed to reduce the workload of women who are the people mainly involved in smallholder gardening, to improve their incomes as well as to provide gainful employment for youth in the rural areas. Also important was the realization that lack of transfer of technology to the smallholder farmer was a major constraint to irrigation development. Another important factor identified as a constraint to the adoption of these technologies was their inaccessibility to the farmers. The genesis of these systems in Kenya in the late 1980s was slow but progressed rapidly in the 1990s.

Two small-scale irrigation technologies introduced in Kenya will be described in terms of system descriptions, their impacts and challenges that need to be addressed for technology transfer to the targeted resource-poor farmers. These two technologies are the small-scale drip irrigation systems and manually operated treadle pumps, and they show promise in irrigation of small gardens. Women's groups have shown a high level of interest in these technologies, which make a direct impact at the household level.

## **Small-Scale Drip Irrigation Technologies**

### ***Drip Irrigation Systems***

Drip irrigation is not a new technology in Kenya. Large-scale farmers have been using it for the past 25 years but it was within the last decade that its use was widespread, mainly in large-scale horticulture and in flower production for export. Conventional drip irrigation systems typically cost Ksh 200,000–300,000 (US\$1=approximately Ksh 75) per hectare for infield equipment alone without considering filters and the water delivery system. They are expensive and require technological know-how in design, installation, management and maintenance. For this reason, drip irrigation has been used by wealthier farmers on high-value fruit, vegetable and ornamental crops. This has changed in recent years with the introduction of small-scale drip irrigation technologies revolving around low-head drip irrigation kits. Three types of small-scale drip irrigation systems (table 1)—bucket, drum and eighth-acre systems—have shown promise in Kenya. The basic small-scale drip irrigation unit is the bucket-kit. The kit comprises two 15-m long drip tubes, with 100 drip emitters and has a capacity to water 100 plants. The bucket-kit system can easily produce sufficient vegetables for home consumption with users even selling the excess. The drum system has a fivefold increase in the capacity over the bucket while an eighth-acre system equals a twentyfold increase in the capacity over the bucket kit to water plants.

*Table 1. Specification of drip irrigation kit systems in Kenya.*

System Characteristics	Bucket	Drum	Eighth-Acre
Working pressure required (m)	1	1	5–10
Average water required per day (liters)	40	200	2,000
Area coverage for vegetable systems (m <sup>2</sup> )	15	75	450
Cost (Ksh [US\$])	1,100 (15)	7,500 (100)	15,000 (200)

Water that is to be used in drip systems may come from wells, ponds, lakes, municipal lines or rivers. Before using dirty water containing bacteria, algae or other aquatic life it is necessary to use extra filtration such as sand filters. Water from wells and municipal supply lines is generally clean and only requires the screen filter supplied with the kit for filtration. The drip lines are installed with the outlets facing upward to minimize clogging risks.

Small-scale drip irrigation technology has attracted women's attention and support. Women's groups, NGOs and community-based organizations (CBOs) have shown a high level of interest in this technology and the demand for the kits is growing.

### ***Genesis***

Early activities in small-scale drip irrigation in Kenya can be traced to Good Samaritan in the 1980s. The small-scale drip irrigation technology at Good Samaritan started in 1988. Two World Gospel Mission missionaries from the USA, Mr. and Mrs. Gene Lewton, came to Kenya to preach the word of God to local communities living in the arid and semiarid areas. They realized that, to make their mission effective, they had to solve issues of food and nutrition constituting the most serious problem affecting the communities. Because of this, the Lewtons began to incorporate agricultural activities together with their religious work. They quickly put up a base at Karen in Nairobi, the present-day Good Samaritan, from where they demonstrated farming techniques to the community. They introduced bucket drip irrigation kits from Chapin Watermatics and later the eighth-acre kits. It was also at this early time that they introduced trays used for growing various types of seedlings. Farmers were also shown how to use the kits to plant various crops, how to construct greenhouses and how to use the trays for growing seedlings. The Lewtons originally used the first greenhouse, constructed at the site, as a church.

Before 1989, the kits were given free to the local people who came to listen to the word of God. In 1989, the Lewtons were able to have a demonstration stand at the exhibition held by the Nairobi Agricultural Society of Kenya where they demonstrated the technology after which many people came to know about it. They continued to sell the drip kits to both small- and large-scale farmers who were interested in them. By April 1994, the kits had been sold to farmers as far as Tanzania and Uganda, thus enabling the technology to spread in East Africa. In April 1994, the Lewtons left for their home country and the technology started to die off at Good Samaritan. Basically, the drip kits that were left behind were sold at cut-prices and the project could no longer sustain itself. There were also issues of poor management of the already installed kits. Problems of clogging in the drip lines were frequent and the community lacked simple innovative measures to maintain the drip systems.

The gap left by the missionaries was later to be filled by the Kenya Agricultural Research Institute (KARI) whose irrigation scientists had, since 1989, curiously followed the proceedings at Good Samaritan. KARI got officially involved in the small-scale drip irrigation technology in August 1996 through a community-development program in Eldoret. The Eldoret community is credited with this initiative as its members made inquiries and requested for assistance. Mr. Micah Cheserem, having seen the technology in Malawi, made the initial contact with KARI. The institute, making use of a grant from USAID, imported material and assembled hundreds of Chapin Watermatics bucket-kits and invited Mr. Stan Doer and Ms. Elizabeth Adams whose training program had shown a promising impact in Malawi. They initiated the Eldoret program, alongside KARI scientists, and followed it up for 2 weeks. For their contribution, the Eldoret farmers paid for the kits but were not charged for the training. The KARI scientists continued to make follow-up visits to assist the farmers to address new challenges in the technology. KARI also set up a demonstration at the National Agricultural Research Laboratories (NARL). After the initial project, KARI continued to set up other pilot areas and import the materials for the systems, making them into bucket-kits for sale. Initially, for demonstration and promotional purposes, KARI freely distributed kits to various women's groups and schools in pilot areas. This initiative could not last long and KARI started distributing the kits at cost and offered free or subsidized technology backup-services. By the end of 2000, over 5,000 bucket-kits and 450 eighth-acre kits had been distributed. In 1999, the Fresh Produce Exporters Association of Kenya (FPEAK) took the initiative and started importing drip irrigation material and selling kits.

### ***Current Status***

During the last few years, some international firms have developed an approach to small-scale, low-head drip irrigation. Chapin Watermatics has developed an eighth-acre drip irrigation system for third-world farmers, and Netafim has developed its "Family Drip System" in response to the demand from small-scale farmers in South America. Both systems are targeted to cover plots of 450–1,000 m<sup>2</sup>, requiring a permanent supply of at least 1,000 liters of water per day at 1–10 m pressure. The initial investment in these systems ranges from KSh15,000 to KSh30,000. While the technological solutions for these "small-scale" systems may be brilliant, the overall cost of installing the systems is prohibitive for most subsistence farmers in Kenya, although these systems have become important as technologies for small-scale commercial farmers.

KARI now has on-station demonstration sites at the NARL in Nairobi, National Dryland Farming Research Centre in Katumani, Regional Research Centre in Mtwapa and Regional Research Centre in Perkerra. These research centers also stock the kits for sale to interested farmers.

KARI scientists have conducted preliminary research on smallholder drip irrigation practices including crops, nutrient management practices and economic evaluation. Scientists from the Department of Agricultural Engineering of the University of Nairobi have also conducted research on the efficiency of different bucket-kit drip irrigation systems. KARI has further developed the standard Chapin module and has scaled up the bucket-kit to a "drum-kit" where five bucket-kit drip lines are connected to a single 200-liter drum covering a larger plot. Along with the drum-kit, drip irrigation systems have been introduced to the small-scale farmers for use in orchards and tree nurseries. Meanwhile, a local NGO, Appropriate

Technologies for Enterprise Creation (ApproTEC) has embarked on a process of scaling down the standard Chapin eighth-acre kit by half to a 1/16-acre kit. They have selected a standard Roto 500-liter tank and are in the process of developing a collapsible stand for the drum. The entire kit will be packaged inside the drum for marketing. ApproTEC has experience in development and marketing of pedal pumps. Thus with KARI scaling up the bucket-kit and ApproTEC scaling down the eighth-acre-kit to plots of 125–250 m<sup>2</sup>, soon the small-scale farmers may be able to purchase, at reasonable costs, kits that will enable a level of production higher than what is necessary as basic food security.

The Fresh Produce Exporters' Association of Kenya (FPEAK), established through a grant from USAID, has initiated the sale of the Chapin Watermatics drip irrigation kits. Through a grant, the FPEAK has purchased a container-load of bucket-kits and eighth-acre kits. In addition, it has set up a small demonstration section at its offices in Nairobi and sells the kits as an income-generating activity to help fund its activities. By the end of 2000, it had sold nearly 1,000 bucket-kits and 150 eighth-acre kits.

The Arid Lands Information Network (ALIN) has purchased 100 bucket-kits directly from Chapin Watermatics, and the ALIN officer has personally distributed them throughout Kenya and Tanzania (Dodoma and Shinyanga). To date, he has sold over 300 bucket-kits on his own initiative.

NGOs have played a key role in disseminating the kit technology. The Intermediate Technology Development Group (ITDG) has distributed some 80 bucket-kits in its agricultural projects in Tharaka and Makeni. More than ten other NGOs and CBOs are disseminating the kit technology in their project areas. One NGO has targeted more than 1,000 bucket-kits for the Kajiado farmers while a church-based organization has purchased over 900 bucket-kits for Meru and Tharaka. Other NGOs have supplied kits to their target farmers on credit.

Local entrepreneurs have shown an interest in providing drip irrigation kits from locally available material, including drip tape that is manufactured in Kenya. This is advantageous because kits are thus readily available and can be produced at lower cost. Research has shown that locally available drip tape is suitable for use in low-head applications.

## ***State of the Art***

### ***Bucket systems***

*Components of the system.* The Chapin bucket-kits present the scaling down of drip irrigation technology to the level of small household vegetable gardens. The bucket system (figure 1) consists of a 20-liter bucket mounted 1 m above the level of the field, a filter stopper fitted into a hole at the bottom of the bucket, two connecting tubes, and two 15-m drip lines with outlets either spaced at 30 cm or 10 cm, depending on the crops intended to be grown. Water flows from the bucket through the filter into the lines, then drips onto the soil next to the plants. The system can be further adapted to suit smaller gardens by laying out 4 drip lines each 7.5 m long or 6 drip lines each 5 m long. The system is installed on raised beds 1-m wide and raised 15 cm above ground level with the bed lengths varying according to the length of drip lines.



Figure 1. Bucket-drip irrigation system.

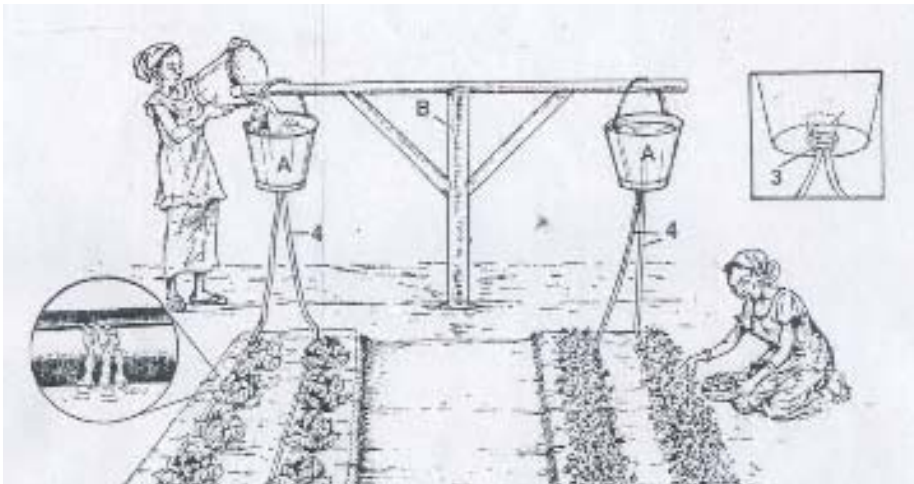

*Aspects of system management.* The bucket-kit system is laid out according to instructions given in an instruction manual. It is important that the drip outlets face upward as this helps prevent sediment settling on the drip emitters and causing blockage. After installation, with the bucket full of water, the end of the drip line is opened to allow water to flow freely. This action creates a fast flow of water that helps flush out dirt from the drip lines. Flushing should be done periodically, every 2 weeks or more frequently, depending on the quality of water used for irrigation.

*Agronomic aspects.* The bucket-drip irrigation systems can be used to grow a variety of crops, depending on the spacing of the outlets on the drip line and plant spacing. Closely spaced crops such as onion, carrot, garlic, cowpea, etc., require a drip line with outlets spaced at 10 cm. The plant capacity is about 300 to 600. Crops like cabbage, spinach and kale require a plant spacing of 30 cm and utilize the 30-cm spacing drip lines. In this case, the plant capacity is 100. Crops such as tomato and eggplant require a spacing of 60 cm and are better adapted to the drip lines with outlets spaced 30 cm but with crops planted alongside opposing outlets. The water wasted when the plants are young is reduced as the plants grow due to the lateral spread of the roots. Farmers should keep a careful watch on soil and plant conditions and irrigate as needed. Under drip irrigation, water is applied frequently, every day, every 2 days or every 3 days.

*Economic aspects.* Bucket-kits last 5 to 7 years if cared for properly. The total cost to the farmer for setting up the system is Ksh 1,100 (\$15) depending on the cost of material for constructing a simple bucket stand and the cost of seedlings planted and other inputs. Economic analysis has shown that the kits are economically viable and that the full investment cost can be recovered within the first season of their use. Farmers have reported profits of

Ksh 2,000 to 3,000 (\$26 to 40) per season producing high-value vegetables. The entire kit inclusive of the bucket is currently available in Kenya for about Ksh1,100 (\$15). Therefore, many resource-poor smallholder producers can afford this technology.

### ***Drum systems***

*Components of the system.* From the bucket-kit, KARI has scaled up the technology to a drum-kit system (figure 2), a fivefold increase in capacity compared to the bucket system. It comprises a drum of approximately 200 liters placed 1 m above ground. A manifold is connected to the drum to distribute water to 10 drip lines each 15-m long, usually laid out in pairs on 5 beds. The manifold is made of  $\frac{3}{4}$  inch PVC material (PVC pipes, tees and fitted bends). The length of the PVC pipe to be used depends on the design of the garden, especially the widths of the bed and paths between sections of the bed. Usually a 6-m length of PVC pipe is enough. Filters used in the drum-kit are the same as those in the bucket system. The length of each drip line used in the drum-kit system is 15 m. A drum-kit manual, packaged with the kit, contains information on installation and management of the system.

*Figure 2. Drum drip irrigation system.*

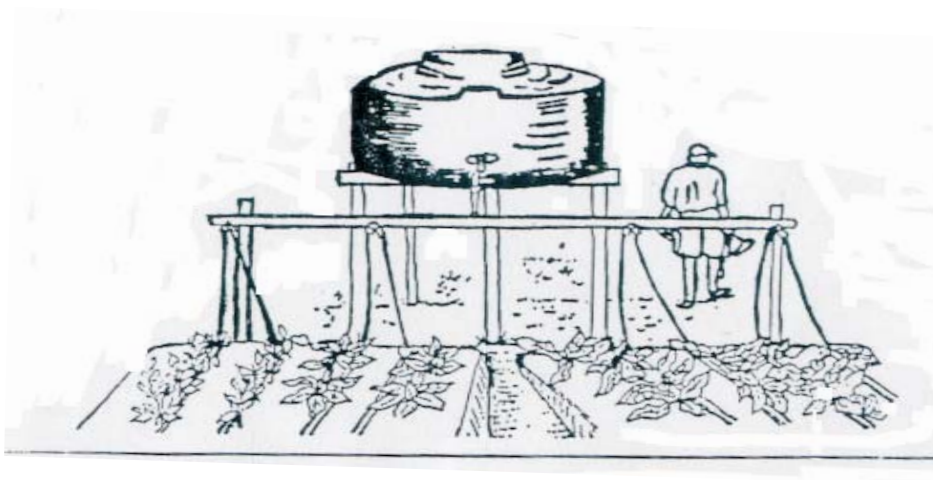

*System-management aspects.* The water is supplied to the plants using the same system process as in the bucket-kit. It is important to close the gate valve while filling the drum and then open it fully to irrigate. Usually, filling the drum once a day is enough, but this depends on the crop type, crop stage and season.

*Agronomic aspects.* The drum-kit system can be used to grow 500 plants if the outlets are spaced 30 cm apart. Closely spaced crops such as onion, carrot, garlic, cowpea, etc., require a drip line with outlets spaced 10 cm apart. Crops such as tomato and eggplant require a spacing of 60 cm and are better adapted to the drip lines with outlets spaced 30 cm apart. Farmers need to keep a careful watch on soil and plant conditions and irrigate as needed. Water is applied frequently, every day, every 2 days or every 3 days. Amounts of water irrigated vary with location, stages of plant growth and season.

*Economic aspects.* For a total investment of about Ksh 7,500 (\$100) a farmer can install the complete drum system and therefore have a crop-production capacity that is five times that of the bucket system. Farmers have reported more profit margins per unit area than when the bucket system is used. Farmers, who used the bucket system earlier, have invested further and scaled up to the drum system.

### ***Eighth-acre systems***

*Components of the system.* The third technology introduced to the farmers was the eighth-acre kit (1/8 acre or 0.05 ha) for vegetable production. The eighth-acre system (figure 3) has a 20-fold increase in plant capacity compared to the bucket-kit. The system comprises a flexible delivering vinyl flat hose to which 20 drip lateral lines are hooked via micro-tubes. The system comes packed in a box and includes instructions on kit installation and management of the system. The kit includes a head unit comprising a filter and pressure regulator, a 15-m flexible hose and 600-m roll of drip tube that is enough to set 20 drip lines of 30 m each. The conditions necessary to install the system are the availability of clean water, minimum water flow of 1 m<sup>3</sup>/hr and minimum water pressure of 0.5 bar.

*System-management aspects.* Screen filters must be cleaned regularly. The ends of the drip lines should be flushed periodically to empty settled dirt from the system. Blocked outlets should be identified early and unblocked.

*Agronomic aspects.* The eighth-acre system presents an example of a 20-fold scaling up of the bucket system. It has a capacity to support 2,000 plants at a spacing of 30 cm between plants and 75 cm between rows or 1,000 plants at 60-cm spacing.

*Economic aspects.* The system, if cared for properly, can be used to grow crops for more than 5 years. The cost of the eighth-acre kit is Ksh 15,000 (\$200). Farmers have reported profits of Ksh 15,000 to 30,000 (\$200–400) per season on high-value vegetables.

Figure 3. Eighth-acre drip irrigation system.

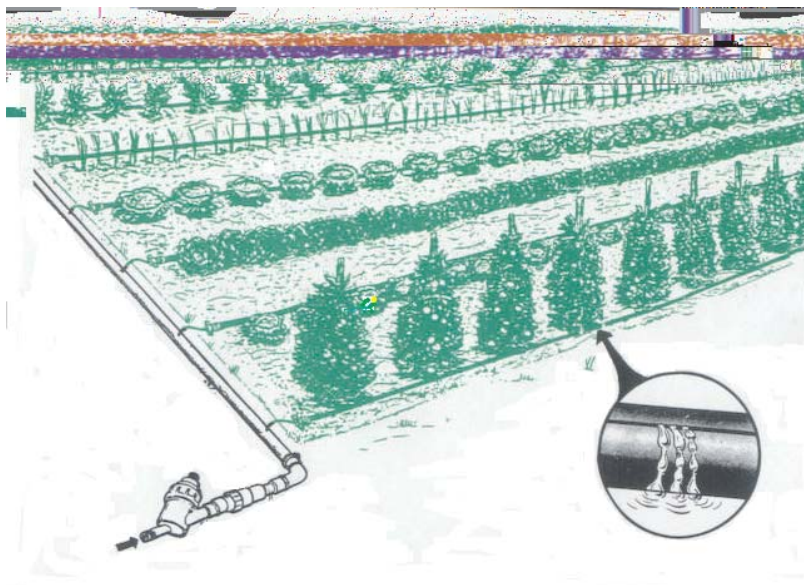

## Pumping for Micro-Irrigation

### *Pedal Pumps*

In addition to drip irrigation that delivers water more efficiently to crops, pumping technologies can help the farmers to increase their irrigated area and production, especially if the water pumped is distributed and applied efficiently. Gasoline or diesel-powered portable pumps seem an obvious answer to the unending toil of small-scale farmers. However, there are two obstacles to the widespread use of these pumps. For one, the economic situation of the farmers can hardly allow for the price and maintenance of the pumps. For another, a 4-HP motorized pump will easily deplete the commonly found water resources in Kenya—shallow wells and water pans—making sustained irrigation impossible. With motorized pumping, extracted water is often delivered to plots in furrows, which is less-efficiently applied compared to hand-carried water that is carefully poured on to the vegetable gardens. Therefore, motorized pumping can become very inefficient, especially in the hands of unskilled irrigators.

Among the most exciting and potentially beneficial technologies is the range of manually operated pumps that have been (and continue to be) used in Kenya. Manual pumps seem to offer a more socioeconomic and technically balanced product to the farmers. Pedal pumps, which are also called treadle pumps, operate the same way. Holding a horizontal arm on a wooden frame or metal frame to steady the body, the operator pedals up and down on two long treadles. The pedaling motion activates two plungers, each positioned within a cylinder. A suction inlet at the bottom connects the water source to the pump's two cylinders. On the upward pumping stroke, water is sucked up into one cylinder while water from the previous

stroke is expelled through the other cylinder. The volume of water pumped depends on a) the height and distance the water is moved, b) the diameter of pump cylinders, and c) energy expended by the operator

The range of human-powered pumps includes the MoneyMaker, Super MoneyMaker and Swiss concrete pumps, which have different attributes as shown in table 2.

*Table 2. Specification of the pedal pumps in Kenya.*

Pump Characteristics	MoneyMaker	Super MoneyMaker	Swiss Concrete
Date introduced in Kenya	1996	1998	1998
<i>Construction material</i>			
Pump body	Metal	Metal	Concrete
Cylinder	Metal	Metal	Plastic
Piston	Metal, rubber	Metal, rubber	Metal, rubber
Other components	Metal, rubber	Metal, rubber	Metal, rubber
Method of joining components	Welding	Welding	Bolts, nuts and screws
Maximum suction depth (m)	6	6	6
Maximum delivery head (m)	0	13	0
Discharge (l/min)	100	100	100
Weight (kg)	15	20	60
Cost (Ksh [\$])	4,000 (54)	5,500 (74)	4,000 (54)

## *Genesis*

In 1984, the Colorado-based International Development Enterprise (IDE), which is an NGO with regional offices in Asia and Africa, became involved in disseminating the pedal pump technology, which had originally been developed in Bangladesh. The organization stimulated market demand for the pumps and helped create a network of manufacturers and sellers of the technology. By the late 1980s, in Asia, the pumps had resulted in a large agricultural expansion with hundreds of thousands of farmers producing irrigated crops in the dry season.

A similar evolution started in Kenya in the nineties through a Kenyan NGO known as ApproTEC established in 1991. Before this, its functions were carried out under the then technical unit that used to operate under Action Aid (UK). Under Action Aid, the technical unit had identified the pedal pump and had started working with it. The pump adapted by ApproTEC was from a design developed and promoted in India by Bob Hyde who worked for the IDE. ApproTEC enlisted the services of Bob Hyde in August 1996 to help start the pedal-pump activities in Kenya.

ApproTEC adopts the following approach:

*Economic research and feasibility studies*

ApproTEC identifies new market/business opportunities by undertaking a subsector analysis to identify market demands in terms of the availability of materials, skills and technologies and the resulting profitability.

*Technology and business-development packages*

ApproTEC develops/adopts/designs technologies required to start such enterprises. In this respect, ApproTEC designs and develops standardized manufacturing techniques, trains manufacturers and develops required business-information packages.

*Promotion, information and marketing*

Since most of ApproTEC's designed/developed business opportunities are new, with donor assistance, it spends a lot of time and money promoting and marketing these new opportunities to encourage many entrepreneurs to invest and create new employment.

*Monitoring and evaluation*

ApproTEC continually monitors the performance of its technologies and responds to the needs for changes to suit local conditions.

It has used this approach to introduce and popularize the pedal pumps in Kenya.

Another organization has also worked with the pedal pump. The Swiss concrete pedal pump for small-scale irrigation is being introduced through an association known as Water for the Third World, based in Switzerland. The origin of this pump, which can be traced to India, is associated with Swiss engineers who started working on the pump with Indian farmers in 1992. The pump was introduced to Tanzania in 1997 in a training workshop and, to date, more than 200 pumps have been manufactured by a pump project at the Tushikamane training center in Morogoro, Tanzania. A participant from Kenya returned with the technology and, in 1998, initiated a local production workshop at ICIPE's Mbita point research center. He has manufactured 10 pumps. The pump promoters are in the process of popularizing this pump technology in Kenya and Uganda.

### ***Current Status***

Although costs in human energy are high, farmers have readily adopted the pump and ApproTEC has promoted the pump to an expanding market. Nearly 6,000 units have been sold in Kenya. ApproTEC has set up a network of pump manufacturers and distributors and frequently advertises the pump through national newspapers. The Super MoneyMaker pressure pump has replaced the MoneyMaker as farmers prefer to irrigate with it using sprinklers instead of furrows. ApproTEC has started scaling down the Super MoneyMaker to a product that is half its present cost.

### ***State of the Art***

#### ***MoneyMaker and Super MoneyMaker pump***

*Components of the pumps.* The MoneyMaker pump is placed above ground, is sufficiently light to be portable and can be moved from the production site at night, is adapted to fitting into existing wells since shallow wells and is guaranteed for 1 year. The pump body, which is the basic structure, is constructed from metal parts. Two pump cylinders each 4" in diameter

are also made of metal. The metal parts used in the piston are joined together by welding. The pedals are of metal construction. Rubber products are used in the piston sleeve and valves.

The first generation of ApproTEC pumps was named MoneyMaker and started selling in the Kenyan market in 1996 at a cost of Ksh 4,000 (\$54). The pump, which is portable, weighs 15 kg and draws water into a furrow and is capable of irrigating 2 acres of land.

In 1998, a manually operated pressure pump known as the Super MoneyMaker pump came into the market. The pump, which weighs 15 kg, is more powerful and able to irrigate 2.5 acres of land per season using sprinklers. The Super MoneyMaker pump costs Ksh 5,500 (\$74).

Figure 4. Super MoneyMaker pump.

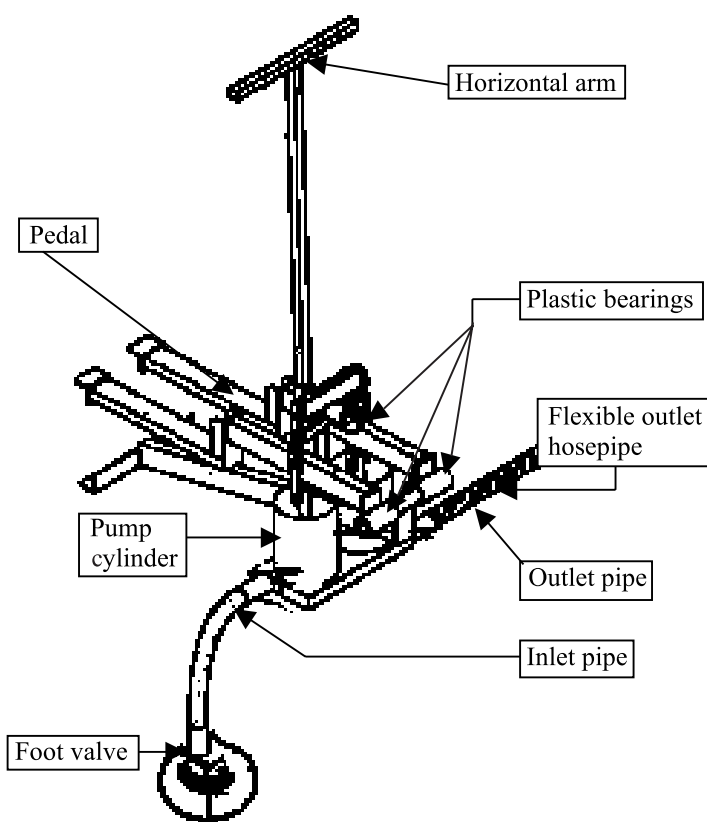

*O&M aspects of pumps.* The smaller MoneyMaker pump is used for suction lifts of up to 6 m and releases the water into furrows. The larger Super MoneyMaker, which has replaced the pump, can be used for suction lifts up to 6 m and a delivery pressure of 13 m. It is used with low-head sprinklers or a hose pipe to irrigate the crops. The pumps, each being 15–20 kg in weight, are light enough to be taken home for safety.

Because grease will damage the rubber cups in the pump it is not applied. Water should be drained from the valve box and foot valve when the pump is not in use to avoid rusting while rubber cups and plastic bearings need to be replaced when they are worn out.

*Agronomic aspects.* Many crops are grown with these pumps but farmers have selected crops with high payback including kale, tomato, cabbage, onion, French bean, spinach and tree seedlings.

*Economic aspects.* Both pumps have the potential to change the livelihoods of the farmers. With the MoneyMaker irrigating up to 2 acres, farmers have reported profits of Ksh 60,000 (\$800) or more per season. The potential for micro-irrigation pumps in Kenya has been estimated to be over 360,000 units. So far, only about 2 percent of the potential has been exploited.

### ***Swiss concrete pedal pump***

*Components of the pump.* The foot-driven Swiss pedal (figure 5) pump is a simple tool for manual irrigation of land. It contributes to increased food production and has demonstrated its value in alleviating poverty for smallholder farmers. The body of the pump, which has two parts—pump head and platform—is cast from steel moulds and is made of concrete. The cylinders are cut from 4-inch PVC pipes. After the mould is assembled, a mixture of cement, sand and gravel, in the ratio of 7:7:10, is prepared and carefully packed into the mould and allowed to cure in water for a minimum of 3 days. The piston, valves, equalizer and pedals are fitted. The piston comprises metallic parts that are connected together by bolts and nuts. Rubber is used in the piston sleeve and valves. The pedals used are made of timber. The pump may be fixed permanently or provided with a platform so that it can be moved.

*O&M aspects of pumps.* The pump draws water from a maximum depth of 8 m and discharges it directly for irrigation, usually by furrow, or leads to a water reservoir. The water should be free from sand, which causes excessive wear to the cylinders. The pump whose weight is about 50 kg cannot be easily stolen. By using concrete for construction, the pump can be used with salt water and requires minimum replacement of the metallic parts, which constitute about one quarter of the pump.

*Agronomic aspects.* The experience with the pump to date has shown that farmers prefer to grow tomato, kale, cabbage, onion and spinach, and tree seedlings.

*Economic aspects.* The pump, which is constructed locally in the village, costs less than Ksh 4,000 (\$54), is easy to use and requires little maintenance. Farmers have reported good returns on investments when pumping for irrigation, with tomato and tree seedlings showing the highest return.



Figure 5. Swiss concrete pedal pump.

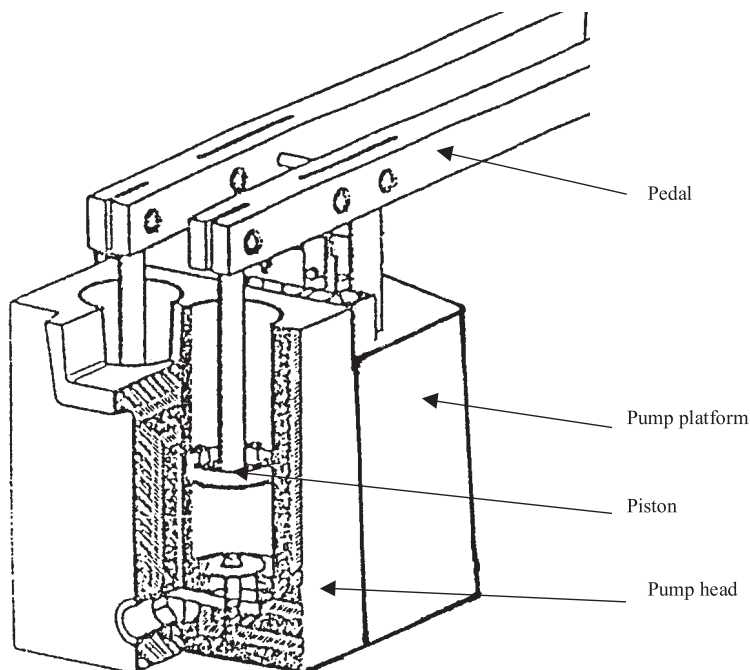

## Challenges to Be Addressed

### *Research and Adaptation of New Technologies*

Lack of appropriate and affordable technologies geared towards poor farmers on small plots is a major constraint to the spread of irrigation in Kenya. Most irrigation equipment is imported and costly. Equipment suppliers are few and products are usually too expensive for smallholders. To address this, therefore, appropriate technologies need to be identified and adapted to suit smallholder farmers. These technologies should be:

- appropriate, simple and, if possible, made using local material and skills
- affordable and attract high returns on investment

Therefore, there is a need for continued research, development and adaptation of the technologies as have occurred in Asia. This also calls for technology and backup-support to the farmers as they face new challenges.

### *Marketing New Technologies*

After appropriate technologies have been identified, the challenge is to promote them to the potential beneficiaries. One problem is to not to over-promote the technology to farmers who

also may be too ambitious, although they may not have the resources, and end up investing in pedal pump or drip systems when the water supply is inadequate. Small farmers should start “thinking big about small-scale irrigation.” By farming on small gardens intensively, farmers maximize production according to available resources. Technology demonstrations should provide enough information, both technical and economic, including information on marketing outlets for the farm produce.

### ***Capital for Small-Scale Farmers***

Poverty is probably the greatest challenge to the adaptation of small-scale irrigation technologies. Resource-poor farmers living below the poverty line do not have resources to take off; the initial problem is access to capital. Along with the technologies, therefore, ways and means should be found for these farmers to access the necessary capital. Some possible avenues include:

- establishing merry-go-rounds, where a small group pools its money, to provide the capital for investment
- involving in other income-generating activities
- funding the dissemination of appropriate technologies for self-help in place of relief food
- ensuring that smallholder farmers have secure tenure over their land
- providing loans to smallholder farmers through micro-credit schemes

### ***Information and Networking***

As the small-scale irrigation farmers take off, they have to face new challenges. Information and networking are important to provide ready information for these new farmers. This should be addressed in the following possible ways:

- Provide information on who is who in the technology-dissemination sector so that the farmers will know where to go when things go wrong.
- Encourage farmers to form small groups to deal with emerging issues (new technology gaps and marketing) and development and maintenance of shared infrastructure.
- Encourage government extension to work with small-scale farmers and help the extension to keep abreast of development in extension.
- Set up regional outlets for dissemination of technology so that farmers can access technologies.

### ***Cultural***

African women, not men, bear the burden of fetching water. Men, not women, are often the heads of the home. Unfortunately, men may be comfortable in letting the women fetch water

from a distance and even use it for hand-watering of plants instead of investing in affordable labor-saving technologies. This is because, culturally, men are not the ones who do the fetching. This problem needs to be addressed from a cultural perspective, in order to sensitize the heads of families on the advantages of adopting these technologies.

### ***Market and Market Information***

With the new technologies, farmers need to address the production strategies. For maximum return on investment, production has to be targeted for the market. Farmers should target their production to the off-season period targeting the local markets when prices are highest. As farmers get organized they should aim at other market outlets including producing for export. To avoid exploitation, by middlemen, farmers should have access to market information. It is necessary to strengthen FOs and networks to minimize the farmers' risks of being exploited by unscrupulous middlemen.

## **Bibliography**

ApproTEC. *Annual reports*. 1996/97.

ApproTEC. *Annual reports*. 1997/98.

ApproTEC. *Annual reports*. 1998/99.

ApproTEC. nd. *Operation manual for the Super-MoneyMaker: Pessure irrigation pump*.

ETC East Africa. 1998. *Report of mid-term evaluation of the ApproTEC MoneyMaker pump*.

KARI. nd. *Garden dip irrigation kits (General manual for eighth-acre systems)*. Nairobi: Small-Scale Drip Irrigation Development Project.

Kihia, J. K.; and R. N. Kamau. 1998. *MoneyMaker suction pedal pump impact assessment in utilisation, job creation and income generation*.

Postel, S., 1999. *Pillar of sand: Can the irrigation miracle last?* Washington, D. C.: Worldwatch Institute.

Sijali, I.V. *Drip irrigation: Options for smallholder farmers in eastern and southern Africa*. Nairobi: (SIDA: Regional Land Management unit (RELMA). (In press)

IWMI/KARI (International Water Management Institute/Kenya Agricultural Research Institute). 2000. *Report on the low-head drip irrigation review workshop at the National Agricultural Research Laboratories, Nairobi*.

Winrock International. 1999. *Review workshop on drip irrigation in Embu and Mbeere districts*.

Zumstein, A.; and A. Kohler. 2000. *Swiss concrete pedal pump: Pedal pump 2000*.



## Part 2

### Smallholder Irrigation in the Basin Context



# Use of Geographic Information Systems for Planning and Management of Smallholder Irrigation and Drainage

*Bancy M. Mati, JKUAT<sup>1</sup>*

## **Introduction**

As the world moves into the information age, meaningful data are becoming the major currency. The value and use of data, and their ultimate form “information” are becoming basic necessities. For any development to take place or for it to be recognized as such, the available data and those that can be collected must be put together in a form that can be easily accessed and understood by users and stakeholders. The price of information can be high, as it encompasses the sum total of investments such as people, facilities, machinery, effort and time needed to process it. Perhaps even higher is the cost of no information, as we may pay dearly for such ignorance. Despite the high costs, information offers an excellent investment, considering its value. In a developing country such as Kenya, the need to put in place spatial databases that assist in planning and management of development programs, such as irrigation, is not only crucial but also a good investment. However, the success or otherwise of such a venture may be based, to some extent, on the available infrastructure. For Kenya, a look at the background information provides a basis for formulating these developments.

## ***Development of Irrigation and Drainage Databases in Kenya***

Kenya lies within the tropical regions where rainfall is characterized by erratic and unreliable patterns, and where rain-fed agriculture is unsustainable for 80 percent of the country. The scarcity of water and reliability of its supply are major constraints for agricultural development. While the average amount of water available to a country remains constant, the demand for water is steadily increasing. As Kenya is a strongly agrarian country, the rapid population increase has pushed the demand for more agricultural land for food production as well as for economic purposes. Two scenarios have emerged: one, where previously protected water catchment areas, such as forests, are opened for agricultural production, resulting in detrimental environmental impacts; and two, semiarid lands previously used as rangelands are cultivated (Kilewe and Thomas 1992), where crop yields under rain-fed agriculture are poor or fail altogether. This has prompted many small-scale farmers to seek irrigation as a solution, to ensure and improve crop production, as well as for raising farm family incomes.

Irrigation development started in isolated parts of Kenya about 400 years ago, but formal irrigation started in the mid-twentieth century, when several irrigation projects were developed. The creation of the National Irrigation Board (NIB) saw the development of large-scale public-settlement schemes. With time, small-scale irrigation development emerged as an important

---

<sup>1</sup>Senior Lecturer, Jomo Kenyatta University of Agricultural Technology, Nairobi, Kenya.



subsector. Irrigation has been identified (IDB 1999) as a possible option to increase food production in the arid and semiarid lands (ASALs) of Kenya, which account for 80 percent of the total land area as well as for intensified land use in high potential areas. However, data on irrigation and drainage in Kenya are scarce and only irrigation schemes of the NIB are well known. Private commercial irrigation, both smallholder schemes and large estates, are less well documented (Republic of Kenya 1990). Hence, more information is required for policy makers as well as administrators. Previous attempts to put together a database of irrigation and drainage in Kenya have relied on ad hoc studies, which provide detailed information for specific projects. Perhaps the most comprehensive database of irrigation and drainage in Kenya was compiled in 1990 (Republic of Kenya 1990). However, even this database was not spatially geo-referenced to permit easy access, analysis and updating of new information. Later work by the Irrigation and Drainage Branch (Republic of Kenya 1995) of the Ministry of Agriculture to put together a database resulted in about 45 reports. These are bulky and are not easy to access by users. Therefore, there is a need for a more flexible and reliable database, such as a Geographic Information Systems (GIS).

Irrigation development revolves round the development of water resources. The major challenge facing planners and managers is that the physical availability of water and land is fixed; yet their demand is growing (Biswas 1990a). Accordingly, the problem is how to balance demand and supply under these increasingly difficult conditions. For many countries, the only solution, therefore, is to manage the available land and water resources in the country in an efficient and sustainable manner. To achieve this, a reliable information base is necessary, which can identify the resources available, their allocation and use (or misuse), the actors involved, their abilities and limitations and the infrastructure available at the national, regional and subregional levels. Such a database is most useful, if it has spatially referenced data, in which the information can be easily displayed on a map. This calls for a Geographic Information System.

### ***Geographic Information Systems***

A GIS has been defined (Burrough 1986) as a set of tools for capturing, storing, manipulating, analyzing and displaying spatially referenced information. Thus, a GIS is not a system which automatically answers all questions, but a set of computer hardware and software which helps the user in the analysis of data (Peccol et al. 1996). GIS technology is nowadays used by millions of people throughout the world, in a wide range of applications. The use of GIS has accelerated in recent years due to the availability of more user-friendly and cheaper computers capable of handling large volumes of data. This is in addition to the availability of data sources in digital formats as well as a clientele with ever-increasing demand for more cost-efficient and timely tabular and spatial information (Mellerowicz et al. 1994; Aalders and Morrison 1999). GIS allows for vast amounts of information on different themes and from different sources to be integrated and displayed in a format that end users can utilize.

## **Compiling the Irrigation and Drainage GIS Database for Kenya**

### ***Data Sources***

In 1994, the Irrigation and Drainage Branch (IDB), Ministry of Agriculture and Rural Development (MARD) compiled one of the most comprehensive databases on smallholder irrigation and drainage (SID) development in Kenya. District Irrigation Engineers (DIEs), with the technical staff of their respective District Irrigation Units (DIUs) collected these data through field surveys. In addition, the Ministry of Water Development assisted with the collection of streamflow data. These data are available at the IDB in 45 volumes referred to as “District Profiles” (Republic of Kenya 1995).

An example of a District Profile, Homa Bay (Ministry of Agriculture and Livestock Development 1995) provides a 125-page document, which weighs nearly 1 kilogram. Some hard copy maps have been provided, while a page of codes is necessary to permit reference to distances to irrigated areas (potential, actual, proposed), market locations, etc. The District Profile contains maps of administrative units, agro-ecological zones, soils, rural access roads, and average annual rainfall. In addition, there is a map of irrigation and drainage project sites, grouped by size of irrigated area. With about 45 such reports, access to irrigation and drainage data can be tedious, slow and inefficient. A GIS database can significantly improve the accessibility to these data.

### ***Preparing the Baseline Data***

For the preparation of the GIS database on smallholder irrigation and drainage (SID) in Kenya, it was necessary to update the District Profiles, as new districts have been created since the preparation of the original data in 1994, and also to update them with new data. Thus, the IDB in collaboration with the International Water Management Institute (IWMI) organized a series of three workshops, covering eastern/coast/central Kenya, Rift valley, and Nyanza/western Kenya. The DIEs were invited to these meetings, where they presented their activities, including updated irrigation and drainage databases for their districts. They were also given basic training in GIS and provided with topographic maps, which they used to estimate the respective Global Positioning System (GPS) of each irrigation and drainage scheme in the district as point data, obtaining the easting and northing coordinates for each scheme. Ideally, it would have been better to have the geo-referencing of the schemes done using portable GPS units at each scheme. However, because of fiscal and logistical constraints associated with such an exercise, the methodology described here was the most practical. Even then, there is still a need to do a more thorough geo-referencing exercise using modern technologies, such as a GPS unit. It should be noted that that database does not include data on the NIB, commercial or large-scale private irrigation schemes.

### ***Preparing the GIS Thematic Data***

The updated baseline data from the District Profiles and the GPS were put in a spreadsheet (Excel). For each district, the following data were compiled for each scheme: Scheme name, easting, northing, total irrigable area (ha), actual irrigated area (ha), ratio of irrigated area (%), water demand (m<sup>3</sup>/s), water supply (m<sup>3</sup>/s), number of farmers per scheme, name of the river or water source, crop types and current status (whether the scheme is operational or not, the

types of water conveyance and any special notes). The data for each district were put in a separate file, and a text file created for it. This was the file put into the GIS.

ArcView GIS (ESRI 1996) was used to prepare maps of irrigation and drainage data. ArcView is one of the leading software products for desktop GIS and mapping, which enables the user to visualize, explore, query and analyze data geographically. One advantage of ArcView is that it allows extensions and add-on programs that provide specialized GIS functionality. Its easy adaptability with text files created from spreadsheets makes it especially useful for interfacing data, especially by inexperienced users. Thus, this software was considered useful in the current project, as well as for long-term day-to-day management of the irrigation and drainage database by the IDB, where it will be used by a wide cross section of personnel.

### ***Preparing the Maps***

In preparing maps of irrigation and drainage, five base maps of Kenya were digitized. These were a) administrative districts as polygons, b) major rivers/streams, c) contours, d) major roads as lines, and e) towns as point data. Only the district map was really necessary for this work. However, the other thematic layers were used for integrity assessment of the data. The map of Kenya showing districts was opened in ArcView and zoomed to show more clearly the district of interest. The irrigation/drainage database text file for that district was then loaded into ArcView. The relative accuracy of the GPS for each scheme was checked for integrity, based on known indicators, such as nearness to towns, rivers and roads, and any corrections cross-checked with the maps. The other thematic layers were then loaded onto the map, which was then printed. A sample GIS irrigation thematic layer for a district is shown in appendix 1 (Embu district), as well as the sample data used (appendix 2). Out of a total of 69 districts in Kenya, 57 have been mapped in this way. However, GPS and baseline data from 11 districts had not been received at the time of writing this paper. The 57 district files (table 1) were combined to create one file containing data on smallholder irrigation and drainage in Kenya. This file is too large to be appended in this paper and, therefore, its contents have been summarized and presented in table 2.

### ***Data Analysis and Presentation in GIS***

Due to the changes in district boundaries from the time (1994) when the smallholder irrigation and drainage data were compiled, there were overlaps in the data presented in districts that had been split up to create new districts. Thus, a cleaning exercise was done to weed out schemes appearing in duplicate across the districts. This was achieved by sorting the data in the spreadsheet by scheme name, then deleting those that appeared twice. Care was taken to avoid losing important details attached to each scheme. These are the data that were used to create the map of irrigation and drainage schemes in Kenya (figure 1).

Table 1. List of districts in the GIS database of smallholder irrigation and drainage in Kenya.

Province	Districts in Irrigation and Drainage GIS Database	Districts Not in GIS Database
Central	Kiambu, Kirinyaga, Maragua, Muranga, Nyeri, Nyandarua, Thika	
Coast	Kwale, Kilifi, Malindi, Taita, Taveta	Tana river, Lamu, Mombasa
Eastern	Embu, Isiolo, Kitui, Mbeere, Meru Central, Meru North, Meru South, Mwingi, Machakos, Tharaka	Makueni, Marsabit
Northeastern	Garissa	Mandera, Wajir
Nyanza	Bondo, Gucha, Homa Bay, Kisii, Kisumu, Kuria, Migori, Nyamira, Nyando, Rachuonyo, Siaya, Suba	
Rift Valley	Baringo, Bomet, Kajiado, Kericho, Koibatek, Laikipia, Marakwet, Nakuru, Nandi, Narok, Samburu, Transmara, Trans-Nzoia, Turkana, Uasin-Gishu	Keiyo, West Pokot
Western	Bungoma, Busia, Butere-Mumias, Kakamega, Lugari, Mt. Elgon, Teso	Vihiga
Nairobi		Nairobi

Table 2. Summary of irrigation and drainage data in the GIS.

Item	Irrigation and Drainage	Irrigation	Drainage	Percentage of Total
No. of irrigation/drainage schemes	2,210	1,860	350	
Potential irrigable/drainable area (ha)	32,8001	243,060	84,941	
Actual area under irrigation/drainage (ha)	56,603	40,265	16,338	
Potential area (%)	17.3	16.6	19.2	
Total no. of farmers	196,864	160,109	36,755	
Water demand (m <sup>3</sup> /s)		0.01–86.8		
Water supply (m <sup>3</sup> /s)		0.01–750		
No. of schemes providing data on crops	1,776			80.3
Schemes growing field crops	1,055			59.4
Schemes growing local horticulture	1,222			68.8
Schemes growing export horticulture	261			14.7
Schemes growing Asian vegetables	97			5.5
Schemes in the GIS database	1,656			74.9

Source: District Profiles database, current study.



Figure 2. Location of irrigation and drainage schemes with respect to rivers in Kenya.

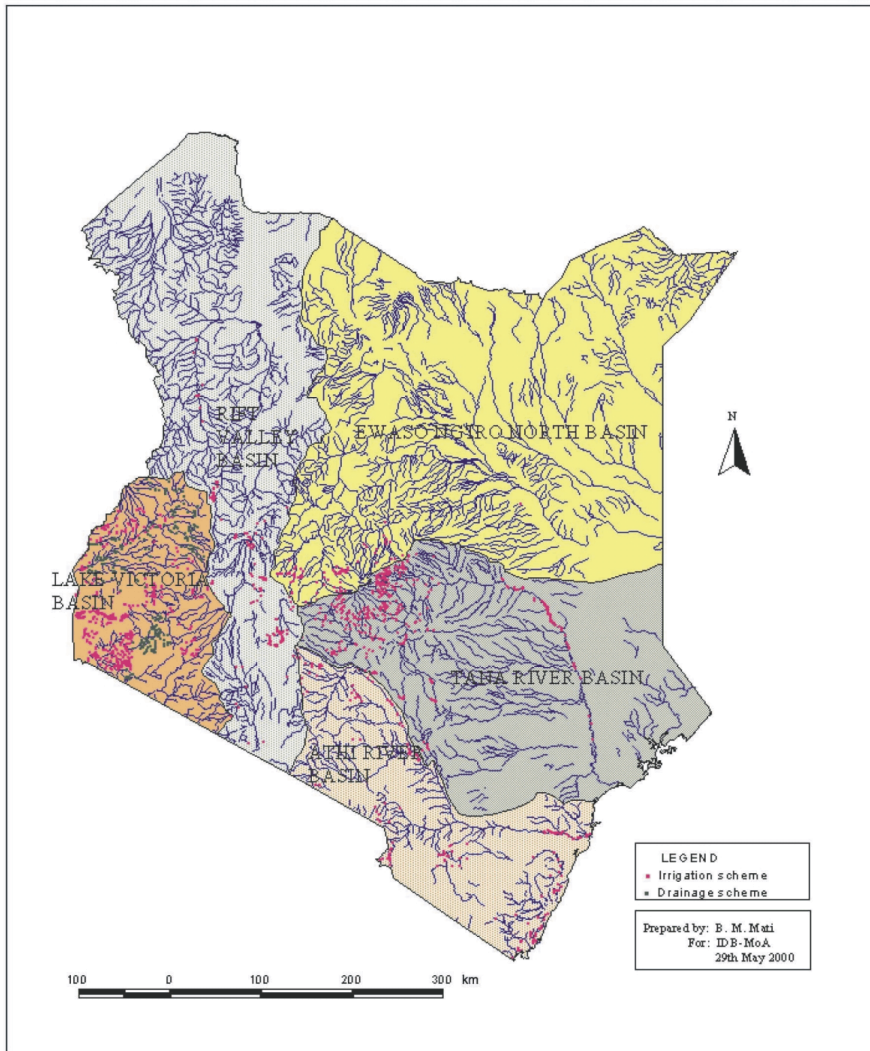

## **Available GIS Data on SID in Kenya**

### ***Districts in the Database***

This paper presents a report on the first comprehensive GIS database on SID schemes in Kenya, which has been prepared using cost-effective methods. It provides the basic variables associated with agricultural production such as area, number of farmers, crops grown, water availability and, most importantly, the geographical location of each scheme. At the time of writing this paper, 57 districts were depicted in the database (table 1), while 11 districts had not yet submitted their data. Such are some of the gaps in this database, which still need to be addressed. As the districts that had not submitted their data in time do not have significant irrigation activities, the current database gives a fair representation of the national perspective.

### ***Distribution of SID Schemes in Kenya***

The location of each SID in Kenya is presented in figure 1. It shows the spatial distribution of the schemes in terms of the administrative districts. These data show that most of the irrigation schemes are concentrated in the following districts: Nyeri, Meru Central, Meru South, Garissa, Nakuru, Homa Bay, Migori, Kisumu, Busia, Bungoma, Taita Taveta and Kwale. Drainage schemes are concentrated in western Kenya in Kisii, Nyamira, Uasin Gishu, Trans Nzoia and Bondo. A common feature of these districts is that they are in the wet agro-climatic zones of Kenya, enjoying a relatively high density of streams (figure 2), proximity to market centers and high population densities. These are the same areas where rain-fed agriculture is also best-suited (Jaetzold and Schmidt 1983). It is ironic that in the dry areas of Kenya, where irrigation is most necessary, very few schemes are found, with the exception of the Garissa district (probably because the Tana river passes through it). From the inventory of existing smallholder irrigation activities, it was noted that most smallholder schemes are presently operated by farmers' own initiative, with little assistance from the IDB or other government agencies.

## **SID in Kenya: A GIS Overview**

Attempts have been made in the past to assess Kenya's irrigation potential. Two authoritative reports are the 1980 National Water Master Plan (Herdjk et al. 1990), compiled by the Ministry of Water Development and the "Study on Options and Investment Priorities" conducted on behalf of the Government of Kenya and the World Bank in 1987. Herdjk et al. (1990) proposed that a policy framework should include a mechanism for updating data on available water resources and competing uses, as well as disseminating such information to planning and implementing agencies. An irrigation policy could also help define how different water sources relate to different types of irrigation. For instance, in the ASALs, a strategy might call for conjunctive use of groundwater and surface water resources to attain local food security. On the other hand, in the medium- and high-potential areas, supplementary irrigation based on surface flows could be perceived as instrumental in increasing productivity of high-value crops. Herdjk et al. (1990) recommended that a study should be done with the aim of defining the type, extent and geographical distribution of services that irrigation enterprises need, and which

of these services could be rendered by the Irrigation and Drainage Branch (IDB), or by the private sector.

### ***Trends in SID Development in Kenya***

Table 2 shows a summary of SID development, as depicted in the GIS database. An analysis of these data takes into account the fact that only 57 districts are represented. It shows that there has been more irrigation development than drainage. From the comments of the current status, it was found that the most common methods of irrigation were furrow, sprinkler and bucket (watering can). Irrigation by bucket-kits has been spreading especially in central and eastern Kenya, where there are many streams.

Table 2 shows that there are 2,210 hectares of documented SID schemes in Kenya, covering an area of 56,603 hectares, constituting only 17.3 percent of the total potential. This area produces the bulk of the local horticultural crops consumed in Kenya, as well as some of the export horticultural crops. About 196,864 farmers are involved in irrigation and drainage, but 81 percent of them are involved in irrigation only. Figure 2 shows that the Tana river basin has the highest concentration of irrigation schemes. The biggest constraints to irrigation development are inadequate water, low technological inputs (e.g., using watering cans is inefficient), poor infrastructure and marketing. It should be noted that only 80 percent of the database had indicated the types of crops grown. From these data, it emerged that field crops and local horticulture are the major products from smallholder irrigation.

The development of drainage has tended to lag behind that of irrigation. Perhaps this has more to do with the topography and the presence of wetlands. From figure 2, it is apparent that most of the drainage schemes are in the Lake Victoria basin. Drainage occupies 16,338 hectares constituting only 19.2 percent of the total potential, as obtained from the current study. This calls for more investigations into the possibilities of reclaiming land through drainage in the areas where it would not lead to adverse environmental effects.

### ***River Basin as a Unit of Interest***

The river basin has become increasingly accepted as a unit for water resources management. The rationale stems from the concept of a river as an organic entity, so that interference with or modification of any part of it will be felt elsewhere in the system (Biswas 1990a). In most cases, river basins have been used for the collection of data on the quantity and quality of water, or for setting up large hydroelectric power-generation projects. In Kenya, eight river basins are recognized for purposes of irrigation and drainage (Republic of Kenya 1990). These are the Tana, Athi, Ewaso Ng'iro north, Ewaso Ng'iro south, Kerio and Turkwel, Lake Victoria, Lake Naivasha and Lake Baringo. Table 3 shows the areas under irrigation and drainage in 1990 compared to their potentials. For the larger basins (Tana, Athi, Ewaso Ng'iro, Lake Victoria and Kerio), the government has set up large state corporations for their management since they have several projects.

Although SID is implemented by the IDB, other players in the irrigation sector are important in getting the general trends of irrigation development in Kenya. These include the Ministries of Agriculture and Water Development, the NIB, three Regional Authorities (Tana and Athi Development Authority, Lake Basin Authority and Kerio Valley Development Authority), District Development Committees (DDC), NGOs, FOs, the private sector, donor agencies and other agencies, e.g., the Horticultural Crops Development Authority (Herdijk et



al. 1990). Although the current GIS database targets only smallholder farmers, it is necessary in the future to develop a more comprehensive database of all irrigation and drainage activities in Kenya, at all scales. Therefore, these agencies should be included as partners in such an endeavor. To conduct basin-wide studies on water availability and use, a complete inventory of water users should be compiled, including seasonal demands. Also, as water becomes scarcer in Kenya, trade-offs have to be made between various uses. Irrigation users will need to provide data on their requirements, including diversions, crop water usage, water losses, etc.

*Table 3. Irrigation and drainage in the major basins of Kenya.*

Basin	Irrigation		Drainage		
	Actual (ha)	Potential (ha)	Actual (ha)	Potential (ha)	Percentage Developed (%)
Tana	18,841	91,000	0	0	20.7
Athi	15,898	49,500	0	-	32.1
Ewaso Ng'iro north	1,236	15,700	0	-	7.9
Ewaso Ng'iro south	172	-	0	-	-
Kerio and Turkwel	4,702	31,000	140	-	15.6
Lake Victoria	3,606	57,000	801	-	7.7
Lake Naivasha	3,577	-	0	-	-
Lake Baringo	971	-	0	-	-
Basin totals	49,003	244,200	941	-	20.5
Basin totals were distributed as follows:					
Commercial, large scale	22,743	-	-	-	46.4
Central managed by basin authorities	10,325	-	-	-	21.1
Smallholder irrigation	15,935	-	-	-	32.5
Smallholder drainage	-	-	941	-	-

## The Case for Setting up GIS Databases

### *GIS in Monitoring and Evaluation of Irrigation Projects*

In most developing countries, the development of irrigation and drainage has suffered from lack of regular monitoring and evaluation. Rarely have the results of proper monitoring and evaluation been used to improve the management of irrigation projects to ensure that the benefits accrue within the planned time horizon. Monitoring may be defined (Biswas 1990b) as “continuous or periodic surveillance over the implementation of irrigated activities, including their various components, to ensure that work schedules, input deliveries, targeted outputs and other required actions are progressing according to plan.” As the primary purpose of monitoring is to achieve efficient and effective project performance, GIS should be made an integral part of the management information system, and thus should be a regular internal activity.

On the other hand, evaluation determines systematically and objectively, the impact, effectiveness and relevance of project activities in terms of their objectives. Therefore, evaluation can be an ongoing activity, fitting easily within a GIS, or it can be done on a periodic basis. Ongoing evaluation with a GIS can be used to determine whether changes are necessary for O&M of the project to ensure satisfactory performance, while periodic evaluation is carried out after longer time intervals, say every 5 years. Periodic evaluation deals with the achievement of socioeconomic objectives, and may not show any discernible change over a shorter period of time. Such evaluation studies have been made in Kenya, with special reference to smallholder irrigation (Republic of Kenya 1990, 1995, 1999).

Most irrigation schemes have undergone some form of evaluation and monitoring. For instance, many irrigation schemes monitor flow rates in the main irrigation canals, but they may not have data on corresponding watercourses. Often, losses occurring in distribution are unknown. In some cases, crop yields are monitored, but even these may not be monitored on a regular basis or with acceptable margins of error. In addition, activities such as types and amounts of chemical inputs, changes in the chemical composition of soil, labor, transport and marketing costs, and even socioeconomic impacts are rarely monitored. If this type of information is available in a GIS format, evaluation and monitoring can be made easier, timely and cost-effectively.

Regular and reliable evaluation of irrigated agricultural projects is not an easy task under even the best of conditions. There are methodological problems that need to be resolved in order to find a cost-effective and reliable approach that can be used within the resources and expertise available (Biswas 1990b). There are also institutional barriers that make the exercise complicated since the demands of national institutions may contradict those of the community. The use of GIS in evaluation and monitoring of irrigation projects makes it easier to:

- determine the extent of achievements of the goals of the project
- identify limitations within the project
- help understand the management of the various interlinked processes and aid in decision making

- verify the relevant project assumptions
- permit transferability of technology to other areas
- plan later phases of the project much better
- contribute to the modification of the organizational behavior on the basis of the relative successes or failures based on reliable experience.
- provide facts and baseline data, which can be used to defend certain actions and also for lobbying for financial support
- provide national policy makers with objective information, which can be used for planning for other areas in the country

### ***GIS in Watershed Management and Basin-Level Studies***

Watershed management, in its broadest sense, is the attempt to ensure that hydrological, soil and biotic regimes, on the basis of which water development projects (e.g., irrigation) have been planned, can be maintained or even enhanced (Biswas 1990c). It is well known that changing land use patterns affects soil and water regimes of any watershed. These changes, if properly managed, could be beneficial. However, unplanned and ad hoc land use changes, as has happened in much of Kenya, have detrimental effects. Individual activities that affect land use practices are generally small and incremental. However, when all the individual activities over an entire watershed are considered, their overall aggregated impacts could be substantial, and these can be shown much better with GIS.

Watershed management has become an important consideration for sustainable water development projects. However, this is not a simple task. It requires simultaneous achievement of many tasks, among which are afforestation, strict control of land use practices, and more emphasis on small-scale structures, such as check dams for better conservation of soil and water. Land use practices are generally very sensitive issues in most countries, at least politically. Thus, success depends on strong policies and willingness of all the stakeholders to observe them. Depending on size, it is difficult to ensure proper implementation of specified land use practices on large watersheds. As watersheds normally cover large spatial extents, GIS becomes a powerful tool for showing trends of the various changes that take place. This can be done through the creation of awareness and setting up of implementation plans, and system evaluation and acquisition (Konecny 1992). It should be noted that, in some cases, it may take years before the benefits of GIS can be effectively realized.

### ***Maintaining and Updating the GIS Database***

A GIS is a dynamic database that should reflect changes occurring in the area of interest. In addition, a GIS must earn its keep. The current GIS database at IDB is envisaged to be dynamic as it still requires a lot of improvement. For instance, it is necessary to complete the data on districts missing from it. In addition, it is important that GPS units are bought and sent to officials in the field so that they can accurately locate even minor farm-based schemes. Current GPS units in the market are accurate to 2-m resolution, so it is possible to get detailed data, which are useful for planning.

The master database at IDB should be disseminated to the field, starting with district-based GIS databases. It will facilitate easier accessibility of data for planning, as GIS is a powerful tool for lobbying, able to show trends in development, and easier to access. A good GIS can also be used to convince District Water Allocation Boards, on the trends in river flow, impacts of excessive abstraction, and for planning water allocation in the district. It can also be used at community level in water users' groups to help them allocate water better.

There are cost implications associated with any GIS database. These include the cost of data collection and entry, digitizing maps and dissemination. These costs can be met by introducing some cost-sharing element in data dissemination. For instance, a department wishing to access the GIS database for information should be charged a fee. There are many people who would be interested in such a database including researchers, project managers, donors and the farmers themselves.

### *Conclusions*

The need for a GIS database of irrigation and drainage in Kenya was expressed over 10 years ago. However, in the intervening years, much of the GIS work at IDB has been ad hoc, project-based work, usually limited to the preparation of hard-copy maps of specific project areas of interest. Until now, all the data on irrigation and drainage could only be obtained from volumes of records and files, which are bulky, difficult to access and are few in number. The GIS database prepared in this project can contribute to improved planning and management of irrigation and drainage in Kenya. As an output of the GIS database exercise, it is now possible to easily extract scheme-, district- and national-level information. The current database obtained that the highest concentration of smallholder irrigation schemes are in the Tana river basin, while drainage schemes are concentrated in the Lake Victoria basin. Also, availability of water, roads and market centers appears to affect the development of irrigation. It was found that only 17.3 percent of the irrigation and drainage potential has been tapped in Kenya, benefiting nearly 200,000 farmers. The poor performance of this sector needs to be examined.

The advantages of a GIS database over conventional methods have been presented. The use of workshops to assist in preparing the current database was based on available resources and time. The database obtained is accurate within reasonable limits, but much work is needed to improve it. More needs to be done to make the GIS functional and self-sustaining. Among these activities are the need to train the staff at IDB in GIS, as well as the District Irrigation Engineers. Next is to equip them with modern GIS hardware and software, to enable them to update the data accurately. Also needed is publicity to make known the existence of the database, and to get clientele for it. It is also necessary to sensitize prospective users so that they can be aware of what they are missing. GIS is a powerful tool for planning, management and troubleshooting of problems, including maintenance requirements. But this cannot happen without continuous data collection from the field. Such data can come from several sources, including engineers, farmers, market surveys, etc. Proper planning and management of water resources, and irrigation and drainage that result from efficient data management should, in the end, benefit smallholder farmers.

Appendix 1. Smallholder irrigation schemes in the Embu district.

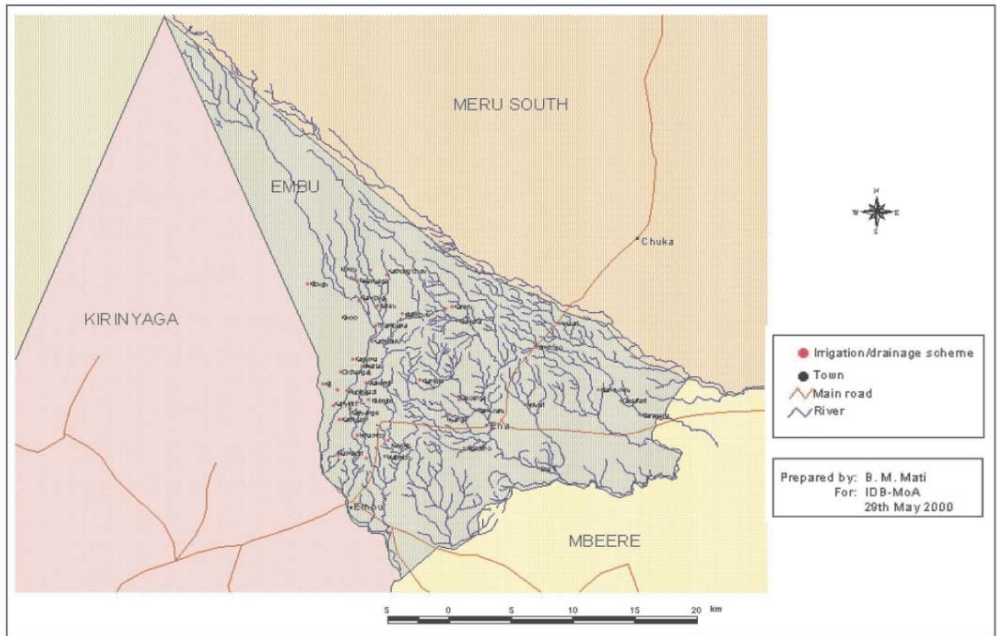

Appendix 2. Smallholder irrigation data for the Embu district.

Scheme Name	Easting	Northing	Potential Irrigable Area (ha)	Actual Irrigated Area (ha)	Area Irrigated (%)	Water Demand (m <sup>3</sup> /s)	Water Supply (m <sup>3</sup> /s)	No. of Farmers	Water Source	Crops Grown
Kiandundu	347,300	9,950,400	40	0	0	0.04	0	30	Gachungu	
Kianjuki	332,900	9,951,200	30	0	0	0.03	0	25	Kapingazi	
Kiaragana	350,600	9,948,300	80	0	0	0.08	0	40	Karurumo	
Kibugu/Nguviu	323,800	9,959,300	320	0	0	0.014	0	1,000	Rupingazi	
Kierisha	335,900	9,956,200	14	0	0	0.036	0.036	25	Kaena	
Kigaritho	336,500	9,945,500	15	1	7	0.02	0.059	20	Kamururu	Kales, tomato, F. bean, chili
Kii	325,100	9,950,900	20	0	0	0.02	0.059	0	Kii	
Kithanje	326,200	9,950,400							Gichangai	
Kivingiri	328,700	9,949,600	18	10	56	0.018	0.02	18	Kapingazi	F. bean, tomato
Kivoo	328,700	9,956,900	13	1	8	0.013	0.08	3	Nyanjara	F. bean, tomato
Majimbo	330,100	9,944,800	30	1	3	0.03	0	80	Kapingazi	Tomato, F. bean
Makengi	328,600	9,951,000	40	0	0	0.04	0	50	Kapingazi	
Mukongoro			10	0	0	0.01	0.107	25		
Mwiria	328,200	9,952,400	30	0	0	0.03	0.118	0	Rupingazi/Nyanjara	
Ndaari	344,100	9,956,000	20	0	0	0.02	0.036	23	Gitwa	
Nduuri	341,400	9,949,200	15	1	7	0.02	0.036	25	Gachichiro	Kales, tomato
Nthambo/Njukiri	327,800	9,946,600	80	0	0	0.50	0	160	Kapingazi	
Nyange	335,100	9,948,300	30	10	33	0.01	0	25	Kamururu	Chili, kales, F. bean
Riamaciri	326,300	9,944,900	10	5	50	0.10	0.368	35	Rupingazi	F. bean, maize
Rianjeru			100	15	15	0.04	0	40	Rupingazi	Tomato, onion
Rupingazi	327,000	9,950,300	40	15	38	0.03	0.025	250	Rupingazi	
Rwanyaga/Gekago	327,800	9,959,600	32	0	0	0.03	0.025	17	Nyanjara	
Thambana	329,300	9,955,800	80	0	0	0.08	0.025	300	Thambana	

Note: The column on current status has been omitted due to lack of space.

## Literature Cited

- Aalders, H.; J. and Morrison. 1999. Spatial data quality for GIS. In *Geographic information research: Trans-Atlantic perspectives*, ed. Taylor and Francis, 463–475.
- Biswas, A. K. 1990a. Objectives and concepts of environmentally-sound water management. In *Environmentally-sound water management*, ed. N. C. Thanh and A. K. Biswas. Delhi, India: Oxford University Press, 30–58.
- Biswas, A. K. 1990b. Monitoring and evaluation of irrigation projects. In *Environmentally-sound water management*, ed. N.C. Thanh and A. K. Biswas. Delhi, India: Oxford University Press, 119–140.
- Biswas, A. K. 1990c. Watershed management. In *Environmentally-sound water management*, ed. N.C. Thanh and A. K. Biswas. Delhi, India: Oxford University Press, 155–175.
- Burrough, P. A. 1986. *Principles of geographic information systems for land resource assessment*. Oxford, UK: Clarendon Press.
- Davies, B. 1996. *GIS: A visual approach*. Santa Fe, USA: Onward Press.
- ESRI (Environmental Systems Research Institute). 1996. *ArcView GIS. The geographic information system for everyone*. Redlands, California, USA: Environmental Systems Research Institute, Inc.
- IDB (Irrigation and Drainage Branch). 1999. *Stakeholder seminar report on smallholder irrigation and drainage development*. Nairobi: Irrigation and Drainage Branch, Ministry of Agriculture and Rural Development.
- Herdjk, A.; G. Diemer; J. Kimani; M. Mukolwe; and M. Thairu, eds. 1990. *Evaluation of small holder irrigation development project. Small holder irrigation: A large challenge*. Nairobi, Kenya: Ministry of Agriculture, Irrigation and Drainage Branch, and The Netherlands: Ministry of Development Cooperation.
- Jaetzold, R.; and H. Schmidt. 1983. *Farm management handbook of Kenya. Vol. II/B. Central Kenya*. Nairobi, Kenya: Ministry of Agriculture.
- Kilewe, A. M.; and D. B. Thomas. 1992. *Land degradation in Kenya. A framework for policy and planning* (3 volumes). London: Commonwealth Secretariat.
- Konecny, G. 1992. Basic considerations for the implementation of spatially based information systems. In *Analysis of earth observations space data integration. Proceedings of the EARSEL workshop, Sinaia, Romania, 1–11*.

- Mellerowicz, K. T.; H. W. Rees; T. L. Chow; and I. Ghanem. 1994. Soil conservation planning at the watershed level using the Universal Soil Loss Equation with GIS and microcomputer technologies: A case study. *Journal of Soil and Water Conservation* 49(2): 194–200.
- Ministry of Agriculture and Livestock Development. 1995. *District profile: Homa bay district, Nyanza province*. Nairobi: Irrigation and Drainage Branch, Ministry of Agriculture and Livestock Development.
- Peccol, E.; A. C. Bird; and T. R. Brewer. 1996. GIS as a tool for assessing the influence of countryside designations and planning policies on landscape change. *Journal of Environmental Management* 47: 355–367.
- Ramasubramanian, L. 1999. Nurturing community empowerment: Participatory decision making and community based problem solving using GIS. In *Geographic information research: Trans-Atlantic perspectives*, ed. Taylor and Francis, 87–102.
- Republic of Kenya. 1990. *Atlas of irrigation and drainage in Kenya*. Nairobi: Ministry of Agriculture, Irrigation and Drainage Branch. 132 p.
- Republic of Kenya. 1995. *District profiles*. Nairobi: Irrigation and Drainage Branch, Agricultural Engineering Division, Ministry of Agriculture, Livestock Development and Marketing, and Nairobi: Japan International Development Cooperation Agency.
- Republic of Kenya. 1999. *The study on community-based small holder irrigation development project*. Promotion of horticultural production in the foothills of Mt. Kenya. Main report for feasibility study. Report No. 42. Nairobi: JICA and Ministry of Agriculture.





# Preliminary Evaluation of Irrigation Development in Kenya

*Stephen N. Ngigi<sup>1</sup>*

## **Summary**

Sustainable agricultural development, especially in the water-scarce arid and semiarid areas of Kenya, may not be achieved without due consideration to the management of irrigation and agricultural water resources. Past irrigation interventions in Kenya have had mixed results. Hence the need to critically review and evaluate the performance and trend in irrigation development. Such an evaluation is necessary to guide future development or rehabilitation of irrigation projects.

The preliminary evaluation, based on three workshops held with irrigation officials between November 1999 and February 2000, aimed at identifying issues that required in-depth investigation to analyze factors affecting smallholder irrigation development in Kenya. The evaluation examined such diverse factors as the adoption of precision irrigation technologies, horticultural production and marketing, gender aspects, donor aid and recent trends in irrigation development.

In this paper, the current trends in irrigation development over the last decade are presented for each province. In addition, issues that emerged from the three workshops pertaining to irrigation development are discussed, focusing on problems, current status and recommended courses of action. The broad issues highlighted include project development and implementation, water resources management, marketing systems and infrastructure, advancement of irrigation technologies, socioeconomics, capacity building, and policy, legal and institutional aspects. The conclusions and recommendations provide a way forward to address constraints to irrigation and drainage development in Kenya.

## **Introduction**

The previous update on irrigation development in Kenya, done between 1992 and 1994, resulted in the development of district irrigation profiles. A critical review of these profiles revealed the following:

- Some schemes that were working in the past are no longer operational.
- Information given in a number of districts was contradictory and inaccurate.
- The rate of irrigation development, in general, has been declining. However, some areas of the country are showing positive trends in terms of rates of irrigation expansion.

---

<sup>1</sup>Department of Agricultural Engineering, University of Nairobi, P.O. Box 30197, Nairobi.

- There has been a shift in government policy geared towards cost-sharing and cost recovery.

Therefore, for any meaningful future intervention aimed at improving irrigation development in Kenya, it is a prerequisite to address the issues and reasons for inconsistent development. In view of the existing information deficiency on the current status of irrigation development in Kenya, a preliminary evaluation was carried out.

It is for this reason that IWMI in conjunction with the University of Nairobi and the Irrigation and Drainage Branch (IDB) of the Ministry of Agriculture and Rural Development (MoA&RD) undertook a preliminary evaluation of irrigation development in Kenya. This was accomplished through a series of three regional workshops, whose outcome forms the basis of this paper. The regional workshops were held between November 1999 and February 2000. The participants of the three evaluation workshops were drawn from the IDB, the universities, IWMI, Kenya Agricultural Research Institute (KARI), Ministry of Environment and Natural Resources (Department of Water Development [DWD]) and regional authorities, among other stakeholders. The objectives of the workshops were to:

- update the district irrigation and drainage profiles
- establish the geographical positions of the irrigation and drainage schemes
- identify districts where further and in-depth evaluation would be conducted
- identify further areas of collaboration among IWMI, IDB and the national universities

## **Current Status of Irrigation Development**

### ***Coast Province***

There is a general decline in irrigation development in the Coast province, which can be attributed to various reasons such as insecurity, salinity and sodicity problems, water scarcity and destruction of irrigation structures by El Niño floods. Further, there has been diminishing financial support, inadequate marketing and infrastructure, inadequate technical know-how and lack of both credit facilities and exposure of farmers to new irrigation technologies. The trend has also shown a shift from group-based to individual farmers and also a shift in irrigation technology from gravity to motorized pumps. The rate of irrigation development in the last decade in some districts is as follows: Kwale -40 percent, Kilifi 1933 percent and Malindi -69 percent (see appendix 1).

### ***Eastern Province***

There is a slight increase in the area under irrigation in the Ukambani districts, which could be attributed to external support and growing of high-value crops. IFAD and ADB are assisting with rehabilitation and development of irrigation projects. There is an increased demand for high-valued horticultural produce, mainly grown under irrigation, leading to a consequent

increase in incomes. This has led to increased interest in irrigation, especially individual micro-irrigation enterprises—water-saving irrigation technologies—being promoted and supported by NGOs and church organizations. The rate of irrigation development in the last decade in some districts is as follows: Machakos 6 percent, Mwingi 0 percent and Kitui 25 percent (see appendix 1).

The trend in irrigation development is expected to rise judging by the number of water resources development projects being implemented and renewed interest in irrigation, mainly for horticultural produce. However, it is evident that the number of donor-funded projects has gone down and there has been a rise in the number of independent individual smallholders. There is also a shift from group-based schemes to individual irrigators, which could be attributed to the promotion of new irrigation technologies such as the ApproTec MoneyMaker pump, and low-head drip systems, which have had a great impact, especially at household level.

Some districts within the Mt. Kenya region have recorded a significant increase in the area under irrigation, which can be attributed to financial support especially from IFAD, ADB and Plan International. There is a general increase in the number of individual smallholder irrigators. The increase in irrigation activities can also be due to well-established marketing outlets, especially for horticultural produce. Precision-irrigation technologies—low-head drip kits and treadle pumps—are being adopted in this region. Water availability and high returns from horticultural produce have contributed enormously to increased irrigation. However, environmental degradation has continued to impact negatively on the water resources and hence there is a need to promote soil and water conservation measures in the water catchment areas. The rate of irrigation development in the last decade in some districts is as follows: Mbeere 29 percent, Embu 211 percent, Meru south 200 percent, Tharaka 0 percent, and Meru north 502 percent (see appendix 1).

Isiolo district to the north of Mt. Kenya has recorded an irrigation growth of 117 percent over the last 5 years. This could be attributed to a shift in food-security strategies—adopting of irrigation by traditionally pastoral communities.

### ***Northeastern Province***

Irrigation in the province is limited to the Garissa district, in particular along the Tana river. Irrigation development in the Garissa district has increased by 161 percent over the last 5 years. The trend can be attributed to training of farmers in irrigation activities and funding for rehabilitation and development by various agencies and NGOs. However, despite the increase in acreage, furrow irrigation still predominates.

### ***Central Province***

There is a general increase in the number of group- and individual-irrigation projects mainly due to the high demand and prices for horticultural produce and well-established marketing systems and financial support for group-based smallholder irrigation schemes. Nevertheless, there are some constraints hindering irrigation activities, which include water scarcity (overcommitted water resources), inadequate funds and the high cost of irrigation equipment. The following is the rate of smallholder irrigation acreage increase for the last 5 years: Nyeri 82 percent, Kirinyaga 182 percent, Kiambu 92 percent, Maragwa 308 percent, Murang'a 1,424 percent, Thika 43 percent and Nyandarua 180 percent (see appendix 1).

## ***Rift Valley Province***

There is a positive irrigation development trend in Laikipia, Kajiado and Turkana districts, where the area under irrigation for both group-based and individual smallholder schemes is increasing. For instance, in Kajiado, irrigation area has increased by 125 percent for group-based schemes and 12 percent for individual smallholder schemes while overall irrigation development has increased by 114 percent over the past 5 years. However, the water-saving requirement by the DWD that all water conveyance systems must be lined or piped before issuance of a water permit, is likely to hinder irrigation development by local farmers.

In Laikipia, water-saving technologies, such as water harvesting and precision irrigation, are practiced. Low-head drip systems and treadle pumps are common, which have contributed to a 10-percent increase in area under small-scale farmers (micro-irrigation). Rehabilitation as opposed to expansion is currently the main activity of irrigation development. This can be attributed to the DWD requirement that all irrigation schemes must improve the efficiency of their water conveyance. Supplemental irrigation is also common in the district.

In the Turkana district, irrigation technologies are shifting from heavily mechanized to furrow and micro-basin irrigation to facilitate O&M by farmers. Formation of WUAs to handle O&M has been emphasized. Farmers have organized themselves into cooperatives that assist in acquisition of farm inputs and marketing of produce. In Samburu, the area under irrigation has decreased by 186 percent, mainly due to siltation of the dams, inadequate management, and frequent conflicts between pastoralists and farmers.

Irrigation development in the west Pokot and the Marakwet districts is decreasing largely due to insecurity, cattle rustling, poor marketing infrastructure and the insecure communal land-tenure system. For example, in the Marakwet irrigation scheme, the area of irrigation development has decreased by 76 percent. Further, there has been no notable change in irrigation technologies. In addition, irrigation development in these districts faces many constraints including lack of funds for rehabilitation of schemes, poor infrastructure, poor marketing, lack of coordination between stakeholders and limited water resources.

Irrigation development in Trans Nzoia, Baringo, Koibatek and Keiyo districts indicates an upward trend of 11 percent, 4 percent, 36 percent and 3,600 percent, respectively (see appendix 1), especially for individual small-scale farmers. The Uasin Gishu district has also experienced an upward trend. The trend could be attributed to donor funding, training and exposure and the adoption of high-value crops. However, sustainable increases have not been realized due to limited water resources, poor marketing organization and high investment costs, weak FOs and marketing organizations, low adoption of new technologies, resistance to irrigation by pastoral communities, lack of access to land by the young generation that is willing to venture into irrigation, poor infrastructure, insecurity due to frequent cattle rustling in some areas and inadequate credit facilities.

In the Nakuru district, the area under irrigation has increased by 124 percent while drainage has tremendously reduced due to tribal clashes in the Njoro area. The area now under irrigation is 3,862 hectares whereas the irrigation potential had been estimated at 1,994 hectares. The increase in area under irrigation can be attributed to improved water management practices and the use of groundwater resources, not considered in the estimation of potential irrigable area. The increasing demand for irrigated crops has also contributed to irrigation development.

Another constraint to irrigation development in some parts of the province is the availability and quality of water, especially for groundwater, which tends to be saline. Other constraints are inadequate awareness of the importance of irrigation, lack of technical know-how on the management of irrigation water, lack of capital, poor marketing and infrastructure and lack of credit facilities. It was noted that the proximity of the Eldoret airport alone is not sufficient to induce horticultural production and irrigation development in the area. So far, it is not clear whether the airport will have any effect on irrigation development.

### *Nyanza Province*

Irrigation development in Nyanza has been slow despite the enormous potential, and could be enhanced by addressing major constraints. Appropriate technology should be evaluated and promoted. The role of stakeholders should be well defined and coordinated to sensitize their efforts. Collaboration and networking among stakeholders should be strengthened. Suppliers of irrigation equipment and rural credit institutions should also be encouraged to open outlets in the province.

In the high rainfall districts the focus has been mainly on drainage activities. Although the potential for drainage is large, to date farmers have only carried out limited irrigation and drainage works with assistance from the District Irrigation Units (DIUs). The drainage potential has not been exploited due to inadequate technical assistance leading to over-drainage and soil degradation in some areas, land tenure (poorly drained valley bottoms are officially under the county council) and types of soils (peat and planosols). The farmers need to be trained on sustainable water management practices and the potential of irrigation and drainage to boost food production.

In the drier parts of the province, irrigation activities are limited. Farmers there need to be sensitized on the need and benefits of irrigation. The use of motorized pumps is also limited despite the great potential due to low-lying land next to the rivers, especially towards Lake Victoria. The few farmers with motorized pumps hire them out to other needy farmers at a fee. Group-based irrigation has drastically declined due to poor management and weak FOs—most of them are not operational. However, individual irrigation projects are slowly picking up. Farmers face marketing problems, crop damage by livestock and wildlife, especially by hippos along Lake Victoria. Additionally, farmers lack credit facilities, face poor transport and communication infrastructure and lack a positive attitude towards irrigation, and suffer from inadequate coordination of stakeholders, inappropriate designs and in some limited technical services.

### *Western Province*

Like the Nyanza province, the high irrigation and drainage potential has barely been exploited and in the area under irrigation, performance is low due to weak FOs and lack of credit facilities. Western and Nyanza provinces have high potential for irrigation and drainage but, ironically, they also utilize the lowest, less than 5 percent, of the potential. There is a lot that needs to be done to change the scenario. The awareness and adoption of new technologies, such as drip kits and treadle pumps, are very low and a lot needs to be done to sensitize farmers, the majority of whom use hand-watering. Besides sensitizing the farmers to change their attitudes towards irrigation and drainage, sustainable water management is a prerequisite—combined irrigation and drainage during the dry seasons and draining during the wet seasons. Most of

the farmers grow sugarcane, which, has proved to be less economical as it takes too long to mature. Hence, there is the need to promote crop diversification to address frequent food shortages and overreliance on neighboring provinces for foodstuffs.

This potential seems to have been realized by various stakeholders if the number of active external support agencies is anything to go by. However, their impact has not been forthcoming. Hence the need to evaluate their strategies with the view of developing an integrated approach for management of water resources. While individual irrigation development seems practical and ideal, individual drainage activities are not possible because not all farmers can have adequate drainage outlets within their farms.

Gender issues have also been cited as a constraint to irrigation development in western Kenya. It was noted that men take most of the benefits when maize is grown while women benefit more from vegetable production. While women favor irrigation, especially for vegetables, men, who are the dominant decision makers, are concerned more about rain-fed maize production.

## **Emerging Issues**

These emerging issues were derived during the three regional workshops organized by IWMI in collaboration with the Ministry of Agriculture and the University of Nairobi to evaluate smallholder irrigation development in Kenya between November 1999 and February 2000. The workshops brought together District Irrigation Engineers (DIEs) and officials among other stakeholders. The workshops preceded a preliminary review of district irrigation profiles that were developed between 1991 and 1994, which portrayed an optimistic scenario warranting further evaluation. The workshop methodology included a presentation of updates by DIEs and selected persons followed by plenary and group discussions. The plenary discussions focused on seeking clarification from presenters and comments from participants. During the plenary discussions, emerging issues were identified and analyzed. The analyzed issues were then discussed in detail during group discussions and the outcome presented during the plenary discussion. This section presents a synthesis of the issues that emerged during the workshops.

### ***Project Development and Implementation***

*Financing of irrigation development.* In the past, smallholder irrigation development had entirely depended on donor support. However, with diminishing donor support and economic recession, the future is gloomy unless new strategies are developed. The following are some of the questions we must find answers to before any meaningful change can be achieved:

- Are smallholder irrigation schemes donor-dependent?
- What is the role of the government?
- What needs to be done to support irrigation development?

The decentralization of irrigation development to the DIUs is probably a step in the right direction. The bottom-up approach may provide a means to integrate all stakeholders at district level. Otherwise, it is time to develop strategies that enhance sustainability of smallholder

irrigation projects. The proposed establishment of district irrigation committees seems to be a good idea in order to coordinate irrigation activities and stakeholders in the district. This will contribute to the promotion of irrigation development in the region.

Overreliance on external support and funding has proven unsustainable and hence the need to change the approach to suit the prevailing conditions. The current financing of irrigation projects is mainly on cost-sharing and cost-recovery bases. The role of various stakeholders has also been changing drastically. Unfortunately, the approach by farmers has remained almost stagnant, which has negatively affected irrigation development.

In the past, external support agencies put more emphasis on new projects while the existing ones, most of which required rehabilitation, were ignored. This contributed to the declining irrigation development and poor performance, which could have led to donor withdrawal and apathy. Most projects were mainly supported only up to the project-implementation phase, the other important aspects such as O&M, monitoring and evaluation and rehabilitation being relegated. The results have been low sustainability of donor-funded smallholder irrigation projects. The inadequate project-development approach was compounded by inadequate planning data and low capacity for O&M, and a lack of credit facilities, sense of ownership and attention to rehabilitation.

Therefore, the following needs were recommended:

- Financing of irrigation projects should include all phases of irrigation development.
- Farmers' knowledge and skills need to be enhanced.
- Farmers need to be sensitized to changing government and donor policies.
- The role of all the stakeholders need to be clearly defined.
- Farmers need to be encouraged to get credits from other sources other than bank loans.
- Any perceived cause of failure during project inception and conceptualization need to be addressed.

Farmers should also be encouraged to establish an O&M fund and be trained on the essence of project sustainability. Relevant government ministries should also undertake regular project monitoring to identify and address any eventuality in the course of project development.

Between 1990 and 1992, IFAD and ADB sponsored a study on how best farmers can be assisted. The study recommended that it was not advisable to go back to grants because history had shown that immediately the donor funding ceased, problems were experienced. It was recommended that future development should incorporate farmers' participation to promote sustainability. In the Eastern Province, for example, IFAD provided funds through cooperative banks to be disbursed to the farmers at low rates of interest. Pilot projects were also implemented to try and identify constraints and assess the effect of subsidies.

The loan scheme of the SISDO, an organization formed to counter the unwillingness of banks to fund irrigation projects, was an excellent concept but channeling the funds through cooperative banks, which provided credit at commercial rates meant doom because farmers could not afford the high rates of interest. Nevertheless, there are other rural credit facilities



that have been established, such as K-REP, for funding small projects through credit. Farmers should be encouraged to consider getting credits from them. Due to fluctuations in agricultural production, farmers should be allowed reasonable grace periods before commencing repayment of credits.

*Roles of various stakeholders.* Irrigation development involves various stakeholders whose roles if not well defined and coordinated could be counterproductive. Stakeholders include not only those who initiate, implement and benefit from irrigation projects, but also those who are directly or indirectly affected by such projects. Nevertheless, the most essential stakeholder is the farmer, who, if not properly integrated in project development, may not feel obliged to play his/her role effectively, thus jeopardizing the sustainability of the project.

Stakeholders should be integrated from the beginning of a project and should be involved in the formation of farmers or WUAs, addressing water use conflicts, sensitizing the farmers, funding of irrigation activities, monitoring and evaluation, providing credit facilities and marketing of produce. In the past, stakeholder coordination and collaboration have been inadequate, hindering sustainable irrigation development due to conflicts among stakeholders, water not being properly managed, weak FOs, lack of monitoring and evaluation, poorly sensitized farmers, limited funding, lack of credit facilities and poor marketing.

These limitations could be addressed through effective coordination and clear definition of the roles of stakeholders, formulation of clear irrigation policy, training on the importance of FOs, formation of WUAs, use of adequate baseline information before implementing projects, availability of accessible credit facilities, diversification of credit security, collateral formation and strengthening of marketing groups to enhance bargaining power and search for new market outlets. These call for an integrated approach in irrigation development that incorporates all the stakeholders.

*Sustainability of irrigation projects.* To address sustainability constraints, there is a need to adopt participatory implementation approaches, formulate a comprehensive irrigation policy, and consult, coordinate and collaborate with all stakeholders, provide affordable credit facilities, build capacity of farmers to manage irrigation projects, restrain Ministry personnel on new approaches and irrigation technologies and strengthen FOs, such as WUAs, marketing groups, etc.

The sustainability of irrigation and drainage projects has been discouraging, especially those funded through the government. This can be attributed to negative political influence, weak FOs, poor management, low priority in irrigation and drainage, nonparticipatory development approaches, negative environmental impacts, low productivity and profitability of irrigation and drainage projects, inadequate credit and financing, and unclear and inadequate enforcement of bylaws for group-based projects.

These constraints have led to collapse of projects, underutilization of resources, illegal water abstraction, little involvement of stakeholders, especially women, in the decision-making process, limited funding for irrigation and drainage projects, poor farmers being disadvantaged, credit facilities not being utilized, farmers not willing to cost-share, bylaws being misused, financial mismanagement, and poor project performance below expected levels.

To address these constraints the following should be considered; sensitize farmers to enhance participation; strengthening FOs; training of farmers on leadership and project

management; encouraging farmers to establish revolving funds; enhancing stakeholder collaboration; integration of gender sensitivity and women in decision making; enforcing the Water Act; making EIA mandatory; involving all stakeholders in the formulation of the bylaws; enhancing implementation of the bylaws; promoting crop diversification; providing market information to farmers; encouraging farmers to obtain credits; etc.

### ***Water Resources Management***

Despite the recommendation by Seckler et al. (1998) that water use by the agriculture sector must be decreased to 33 percent by the year 2025 if the water demands are to be met, the Department of Water Development (DWD) estimates that the water demand for irrigation will be 73 percent by the year 2010 (NWMP 1992). This means that a serious water crisis is looming in Kenya.

*Irrigation water management.* To improve irrigation water management in the context of the river basin, there is a need to address watershed degradation, and monitor data on water resources, illegal water abstraction, water conflicts among users and uses, water as both a social and an economic good, and improve water use efficiency at farm, scheme and basin level. In view of the limitations on water resources, there is a need to utilize the water available for productive purposes, promote efficient technologies such as drip and sprinkler and generally train farmers on irrigation water management. Irrigation of fodder crops alongside food crops should be promoted in the pastoral areas as is being done in the Perkerra irrigation scheme to encourage the herders to adopt irrigation.

The following are some of the recommendations for addressing water management constraints: incorporate catchment conservation in water projects, sensitize the farmers on the need for improved watershed management; improve monitoring of streamflow data; ensure water permits are issued before project implementation; enforce adherence to the water allocation in the permit; improve policing mechanisms, sensitize farmers on the value of water, strengthen WUAs to resolve conflicts over water resources and ensure equitable water distribution among various users and uses and promote water-saving technologies, such as precision irrigation.

This issue of institutional collaboration is very important because the above recommendations are beyond the mandate of the MoA&RD, in particular the IDB. Such collaboration is also hampered by administrative boundaries that, in most cases, are not in conformity with hydrological boundaries.

*Water harvesting and supplemental irrigation.* The SIDA-supported Regional Land Management Unit (RELMA) is promoting rainwater harvesting for supplemental irrigation in Machakos and Meru South where runoff from catchments is stored in either shallow wells or ponds. The water reservoirs are used for supplemental irrigation and the rationale is that farmers can use this water to irrigate during the intra-seasonal dry spells, which would otherwise drastically affect yields. This seems to be a promising technology especially in ASAL districts. The technology has proven worthwhile and has high potential in Kenya, especially if combined with water-saving technologies, such as the low-head drip system.

In view of the diminishing water resources, water harvesting should be integrated in irrigation development, especially for supplemental irrigation. To address persistent water-scarcity problems, especially in the ASALs, water harvesting should be integrated with irrigation technologies that are compatible, such as low-head drip (bucket) kits, which have been promoted throughout Kenya. This is being promoted in Laikipia and Baringo districts and has shown promising results.

Soil and water conservation should also be considered in order to reduce the rampant siltation of irrigation canals. This problem has contributed to the abandonment of irrigation in the Turkana district. Rehabilitation should also be given priority while addressing the causes of failure in the first place.

### ***Marketing Systems and Infrastructure***

Marketing is one of the many factors influencing irrigation development. It is a major indicator and determinant of the level of development. Projects have been known to collapse due to frustration in marketing, with farmers giving up farming due to market losses. Poor marketing, which has drastically affected irrigation development, can be addressed through infrastructural development, information availability, establishing strong market groups and production management. In most parts of the country, irrigation development has been affected by low returns, mainly related to poor marketing.

The marketing infrastructure—transport, communication and limited storage facilities—have deteriorated over the years. Inadequate marketing information (pricing, supply, dealers and outlets) has also had its toll. The exploitation of farmers by middlemen and brokers has been disappointing. These constraints are compounded by inadequate production management, which has led to flooding of markets, poor quality produce and low prices.

These constraints can be addressed by improving infrastructure, such as through farmers' self-help, road maintenance and advocacy, establishing and strengthening marketing groups and networks, such as the Fresh Produce and Export Association of Kenya (FPEAK), among others, at the farmer level. Such organizations should assist farmers with information, facilitate contract farming, training and extension services, credit facilities and quality control. The role of the government in protecting the farmers against undue exploitation should be reviewed. The HCDA and FPEAK should discipline dishonest exporters who contravene agreed contracts.

Nevertheless, the brokers or middlemen should not be seen as a problem; sometimes they are a solution, especially where farmers produce in very little quantities, which may not be economical to transport to the market. In such cases, brokers usually collect these small quantities from the farmers and pay at the farm gate. What seems to be the problem is the exploitative practice of some brokers. Some brokers make sure they sign contract agreements with many farmers to ensure that the latter have excess produce with the aim of lowering the prices due to oversupply.

There are also positive experiences, as with big companies such as Homegrown. For instance, in the Laikipia district, big companies—producers and exporters of horticultural products—have been encouraging small-scale farmers by buying their produce and marketing this produce together with theirs. They have also been providing inputs to farmers who sell their produce to them. This has addressed the nightmare of marketing small quantities of produce through middlemen and brokers.

## *Advancement of Irrigation Technologies*

The pace of advancement of irrigation technologies has been persistently slow, despite diminishing water resources and hence the need to improve water management. This can be attributed to inadequate technological transfer and adoption, cultural persistence on growing low-value food crops and the continuing emphasis by the IDB on gravity-fed surface-irrigation systems, which are perceived as cheap to implement. Other factors include inadequate financial resources, lack of information on new technologies and lack of collaboration with the private sector and technology promoters.

To address the above constraints, there is a need for flexibility in future design and rehabilitation of existing projects to encourage precision-irrigation technologies, to link technology development to the issuance of water permits and to regularly train farmers and DIU staff—to expose to new technological development, promote crop diversity to suit improved technology and streamline the policy implementation process.

The adoption of motorized pumps, sprinklers and drip systems (low-head drip kits) can be attributed mainly to individual irrigators who are able to manage them efficiently. Water scarcity and availability of alternatives are also forcing farmers to shift to water-efficient technologies. Another important driving force is demand for high-value crops, and availability of markets, which are giving farmers quick returns to their investments. More interventions are necessary to improve the water use efficiency of group-based schemes through training, strengthening FOs, rehabilitation of schemes, introduction of new technologies and improvement of marketing infrastructure and credit facilities.

## *Socioeconomic Issues*

The socioeconomic issues identified as affecting irrigation and drainage development include insecure land tenure, weak FOs, inadequate utilization of external financing, low production and profitability of irrigation and drainage activities, overdiversified socioeconomic activities, underdiversified agriculture, alternative sources of livelihood and inadequate gender participation in decision-making processes.

These constraints have led to inaccessibility to, and affordability of, credit facilities, poor and low level of management of group-based schemes, lack of entrepreneurship, poor repayment and/or misuse of credit, low scale of operations, inadequate marketing systems and infrastructure, lack of crop diversification, low income, limited labor for agricultural activities and lack of family consensus on credit acquisition.

To address these constraints there is a need to encourage parents to subdivide and allocate land to descendants, formulate guidelines on how to create and sustain an FO, train farmers on credit utilization, retrain field extension staff and farmers on improved technologies, complement ownership, promote irrigation development and adoption as an alternative livelihood, improve transport and communication infrastructure, strengthen FOs and promote gender awareness in irrigation and drainage activities.

*Irrigation economics.* The evaluation of the productivity of water (yield per volume of water) at the field level has not been carried out. With better water management at the farm level, water could be saved and used to irrigate additional land. For example, the Kikima farm in Machakos, which uses water from a reservoir, has managed to attain an irrigation efficiency of

over 80 percent (Mbogo 1999) through improved water management. Economic evaluation of water at the small-scale level needs to be carried out to provide data necessary for future planning. This could provide information on the economic viability of irrigation and a basis for monitoring of irrigation performance.

In the past, irrigation economics has not been given due consideration during the initiation of smallholder projects. This has led to overreliance on government subsidies and low sustainability of group-based schemes. Inadequate consideration of irrigation economics has also led to low adoption of improved water management—water use is not related to productivity. This realization and reduced donor funding have prompted the introduction of cost-sharing policies and the setting up of SISDO to provide credit to farmers.

The expectation that the introduction of irrigation would automatically trigger socioeconomic development, especially in the ASAL regions of Kenya, has not been met. This can be attributed to constraints such as pastoralists' reluctance to adopt farming, dependency created by food schemes, cultural barriers limiting diversification and insecure land tenure.

These constraints could be addressed by creating awareness in the importance of irrigation, adopting a business approach to irrigation development, sensitizing farmers on policy changes, carrying out studies on water use and productivity, reducing levels of cost-sharing, depending on farmers' financial resources, establishing village banks, gradually introducing new policies, hastening issuance of title deeds, promoting low-cost irrigation technologies, improving rural access roads, encouraging marketing associations to emphasize irrigation development and integrating irrigation with other socioeconomic activities.

*Credit facilities.* It has been observed that banks are not willing to fund irrigation projects because of the high risks associated with agriculture. This prompted the formation of SISDO to promote cost-sharing in irrigation and agricultural projects through a loan scheme. However, loan recovery rates have been poor, especially due to fluctuating and unpredictable returns. In other cases, the farmers perceived SISDO as a government department and ignored loan repayments. The situation was worse for group-based projects.

SISDO's experience with credit financing of irrigation development revealed a need to review a whole chain of constraints associated with it. This could be a turning point for funding of irrigation development, which has been hampered by lack of avoidable credit facilities. The recovery of loans to purchase inputs is estimated at 70-95 percent while loans provided for infrastructure developments have proven difficult to recover (Orego 2000).

### ***Capacity Building***

The capacity-building issues that affect irrigation and drainage development were identified as lack of adequate skills in water management (application and frequency), inadequate awareness of government legislation and policy, inadequate leadership and financial management skills, lack of an adequate information on new or improved technologies, lack of an adequate and reliable database on irrigation and drainage, inadequate practical orientation for graduates, inadequate gender awareness and inadequate extension services. These constraints have led to a lack of adequate skills, weak FOs, low adoption of new technologies, inadequate designs of projects, poorly trained staff, gender insensitivity in irrigation and drainage, limited extension services and eventually to low productivity.

To address these constraints, there is a need to expose farmers and irrigation staff through demonstration training to improve water management technologies, establish model or demonstration farms in every district, promote exchange visits, train leaders on leadership and management skills and strengthen FOs. Marketing groups should regularly update DIU staff and farmers on new technologies; farmers should be provided with information on research and manufacturers; reliable databases and information centers need to be provided; practical oriented training should be provided in the universities; on-the-job training for field staff should be encouraged; women should be encouraged to be involved in decision-making processes; and the training curriculum in public universities should be reviewed to suit the prevailing conditions.

### ***On-the-Job Training***

The syllabuses of institutions of higher learning have not been keeping pace with recent technological development; neither do they incorporate farmer-initiated technologies (Karanja 1999). Thus the MoA&RD, in particular KARI and IDB, should provide research priorities and data, as it is clear that in the past, most of the research activities had no relevance to conditions on the farmers' fields. The collaboration among MoA&RD, universities and farmers needs to be strengthened. It was noted that one way of strengthening university-farmer linkages is to encourage on-farm research activities, which will enhance capacity building and adoption of research findings. KARI's commitment to this change in the research agenda will strengthen its role in irrigation development.

Transfer and dissemination of improved technologies have been hampered by inadequate extension packages—the majority of farmers have no access to relevant information on recent technologies, irrigation water management, sources of funding, etc.,. Some of the extension officials are also not abreast with recent irrigation technologies; hence the need for continued training to enhance irrigation development.

### ***Policy, Legal and Institutional Issues***

Policy, legal and institutional issues need to be addressed to resolve conflicts over water resources, marketing of produce, planning of irrigation and drainage development activities, stakeholder coordination and collaboration, and enforcement and implementation of policies and laws. These issues have not been addressed adequately, leading to uncontrolled and illegal abstraction of water, conflicts among uses and users, poor marketing of produce, poor infrastructure, weak FOs, lack of reliable data for planning, low prioritization of irrigation and drainage, underutilization of irrigation potential, inadequate financial resources, drastic shifts in government policies, uncoordinated efforts by stakeholders, conflicts of interest among stakeholders, breakdown in law and order in most group-based irrigation schemes, low morale of DIU staff, and farmers being exposed to different project-implementation approaches.

To address these constraints, there is a need to involve all stakeholders in all facets of project development, formulate responsive and dynamic bylaws, revise the Water Act, sensitize farmers on changing government policies, encourage farmers to establish marketing groups, advocate for improved infrastructure, prioritize irrigation and drainage among other agricultural sectors, establish more reliable databases, gradually introduce new policies, consider water as a social and an economic good, establish district irrigation committees to coordinate the

activities of various stakeholders and establish WUAs and FOs to seek legal advice on the formulation of bylaws.

*Policy.* Policy is the main factor affecting irrigation development in Kenya. Until the policy issues are addressed fully, no meaningful progress will be realized in the irrigation sector. The issue of policy needs to be addressed urgently if the current predicament in irrigation development is to be reversed. The MoA&RD (IDB) has drafted an irrigation policy, which emanated from the 1992 irrigation workshop but this has not been adopted.

There has been a change in government policy, from donor reliance to self-reliance, from grant to cost-sharing and cost-recovery. This sudden shift in policy has impacted negatively. It is felt that the new policy was implemented too fast, farmers were not given enough time, and there was no transition period; hence farmers could not cope with the policy. Current DIU procedures require that farmers seek assistance from the DIU but the DIU staff do not look for farmers who need help. To enhance adoption, new policies should be developed with farmers and introduced gradually.

Group-based irrigation development has decreased tremendously. This could probably be attributed to a new policy by MENR (DWD) that requires improvement in the efficiency of irrigation water conveyance. Since 1997, the issuance of water permits has been tied to these conveyance improvements.

In view of the changing policies, there is a need to harmonize different approaches being used by various external support agencies (ESAs). This could be achieved through coordination of all irrigation-development activities in an area and formulation and implementation of a comprehensive policy. Some ESAs neither consider prevailing policies nor consult relevant government departments leading to confusion among the farmers.

The-cost recovery approach in financing the development of irrigation systems was adopted in 1992. Under this policy, farmers were required to meet the full cost of implementing irrigation projects through a loan from SISDO, which was based on the Grameen Bank approach in Bangladesh (Oregio 2000). However, the approach has not been successful mainly due to lack of clear policy on irrigation development; other stakeholders not promoting a cost-recovery policy; SISDO's and IDB's roles being not well coordinated; high cost of irrigation development; inequity in water allocation and hence production and repayment power; lower returns than anticipated; and high interest rates and relatively short repayment duration. Nevertheless, despite these shortcomings, it has been observed that farmers are willing to pay for irrigation services if it results in better services and higher production and returns.

Farmers in Laikipia and Nyandarua districts have been paying for services rendered by the DIU staff. Initially, farmers used to contribute only part of the cost while the IDB contributed the rest. However, IDB contributions have not been forthcoming and the farmers opted to meet the total cost. This means that the farmers value the services provided by IDB and they see irrigation as a business enterprise. They are aware of the benefits and hence are willing to pay. This is a positive turn of events that needs to be promoted if the current trends in irrigation development are to be reversed.

*Legislation.* It is evident that the majority of the smallholder irrigation farmers in Kenya are abstracting water illegally. A survey done upstream of the Mwea irrigation scheme (Kamundia 1999) revealed that more than 90 percent of the abstractions were illegal and the quantity of

water abstracted is not accurately measured. In addition, there are numerous temporary abstraction points—also illegal—where portable motorized pumps are being used.

This makes planning for irrigation development virtually impossible, as accurate data are not available. Cases of illegal water abstraction are rampant. While the water permit application procedures are clear, they are not strictly adhered to. The issue of continuous monitoring of water abstraction needs urgent attention to enhance water management at the river basin. Circumstances are dynamic and the upstream users of today are the downstream users tomorrow. There is a great loss of investments when no water flows to the downstream users, especially during critical crop-growth stages when irreversible losses can occur.

There is much confusion about the high-flow and low-flow abstraction requirements. In many basins all low-flow permits have been allocated and only high- or flood-flow permits are issued. These require farmers to construct a 90-day storage in order to adequately irrigate their crops. Often, farmers do not understand that their abstractions can only be made during high-flow periods. These periods are not clearly defined and enforcement is sporadic. The system, generally, results in misunderstanding and is a source of conflict.

*Institutions.* There is an urgent need to harmonize the operations of the stakeholders involved in irrigation development with the aim of reducing duplication of functions and confusion. Each public institution should have a clear contribution to make to the sector and linkages need to be properly put in place to ensure coordination of activities to enhance achievement of desired national goals. The public institutions should be restructured to reflect the government's emphasis on delivery of services to the people. The organizational/institutional aspects and needs of various types of small systems (group-based and private) need to be studied in a participatory manner with the farmers in the schemes.

The proposed restructuring should take into consideration prevailing government policies and legislation. For example, in this era of income generating within government departments, a conflict seems to be brewing between the MENR (DWD) and IDB with regard to design and implementation of irrigation projects. While the MoA&RD has a mandate to undertake smallholder irrigation development, the DWD has also a division dealing with minor irrigation improvement. There is a need to address this institutional confusion to minimize existing conflicts. This calls for enhanced collaboration and networking among all stakeholders.

### ***Conclusions and Recommendations***

The preliminary evaluation identifies the many constraints facing the smallholder irrigation and drainage development in Kenya. The following are a number of activities that need to be addressed by various stakeholders:

- Evaluate the past and current performance of smallholder irrigation and drainage schemes to identify what has gone wrong and suggest appropriate actions to improve the situation.
- Trends in irrigated area development in the districts are not uniform—in some districts the area under irrigation has increased, in others it is stagnant or even decreasing. Ascertain why these differences exist and learn from successes and failures.



- Build the capacity of farmers and DIES through exchange visits, and training at demonstration centers.
- Enhance collaboration among stakeholders including farmers.
- Conduct and disseminate adaptive on-farm research on irrigation and drainage in collaboration with all the stakeholders.
- Appoint assistants to DIES who are familiar with improved irrigation and drainage technologies.
- Make water users pay an appropriate and reasonable amount for the water they use. This should be based on policies stipulating how much of the estimated cost of the water, including costs of O&M of the system, can be brought to bear on farmers, on the general enforcement of the policies and fee collection, and on the means to measure reliably the amount abstracted by the various users.
- Build the capacity and morale of DIUs, DIDUs and extension service officials through training and financial incentives for providing good services to water users.
- Adopt viable policy changes and keep all stakeholders informed about changes in government policies.
- Encourage farmers to obtain credit and build their capacity to manage their financial resources.
- Encourage commercial farming and diversification of agricultural production.
- Improve on-farm water management and incorporate water-saving technologies.
- Strengthen FOs and WUAs through training in decision making, project/scheme management, leadership skills, financial management, record keeping and enforcement of bylaws. All training should encourage participation by both men and women.
- Encourage and improve on-farm innovations and experimentation.
- Promote local processing of farm produce to increase productivity and profitability.
- DIES and IDB staff should be trained on GIS applications to make use of databases being established.
- Sample districts should be selected for in-depth studies whose results should evolve a strategy to raise income for farmers' irrigation enterprises. The objectives of future studies should include analysis of matching water demands and supplies, quantifying production per unit of water, the efficiency of water use in different kinds of irrigation schemes, and water use efficiency at river basin level where various systems and other water users are considered in an integrated approach.

- Examine the role of drainage in western Kenya with the aim of developing a work plan for the installation of drainage systems.
- DIEs should articulate their information needs, based on the situation on the ground.
- Document the work that has been done on irrigation and drainage in the form of a bibliography.
- Strengthen the Kenya Society of Agricultural Engineers (KSAE) and also establish a Soil and Water Management Network to coordinate national initiatives.
- Address the issue of land tenure and access to water in some ASAL districts.
- Stimulate the use of water-saving irrigation technologies and disseminate information on precision-irrigation systems to individual smallholders.
- Promote bottom-up, participatory and integrated approaches in which IDB partakes as an equal stakeholder.
- Credit institutions should recognize farmers' seasonal need for money and provide a reasonable grace period for repayments.
- The government should appoint a body charged with the resolution of conflicts arising from competition for water and develop suitable guidelines for the resolution of such conflicts.
- Examine current and future irrigation water demands in the context of watershed management.
- Establish appropriate marketing facilities.
- Review the project approach to scheme rehabilitation.
- Finally, establish an Irrigation and Drainage Working Group—composed of all stakeholders—to monitor progress and advise with respect to irrigation and drainage development in Kenya.

The long list clearly indicates that it cannot be left to the government alone but that all the stakeholders should collaborate in addressing the challenges, opportunities and constraints of irrigation development in Kenya.

### Some Current Trends in Irrigation Development (1999-2000)

District	Area Under Irrigation (ha)		Percentage Development
	1990–1995 <sup>a</sup>	2000 <sup>b</sup>	
Baringo	1,914	1,994	+4
Embu	18	56	+211
Garissa	537	1,400	+161
Isiolo	484	1,050	+117
Kajiado	1,993	4,274	+114
Keiyo	5	188	+3660
Kiambu	942	1,804	+92
Kilifi	6	122	+1,933
Kirinyaga	257	725	+182
Kitui	60	75	+25
Koibatek	59	80	+36
Kwale	2,526	1,511	-40
Laikipia	200	220	+10
Machakos	300	318	+6
Malindi	72	22	-69
Maragwa	256	1,044	+308
Marakwet	6,200	1,485	-76
Mbeere	528	682	+29
Meru north	166	1,000	+502
Meru south	20	60	+200
Murang'a	33	503	+1,424
Mwingi	58	58	0
Nakuru	1,725	3,862	+124
Nyandarua	200	560	+180
Nyeri	565	1,029	+82
Samburu	20	7	-186
Tharaka	260	260	0
Thika	195	279	+43
Trans Nzoia	91	100	+11

<sup>a</sup>Values obtained from the District Irrigation Profiles developed between 1990 and 1995.

<sup>b</sup>Values obtained from the three regional workshop reports on Evaluation of Irrigation Development in Kenya.

## Literature Cited

- Kamundia, S. 1999. Survey of water uses upstream of Mwea irrigation scheme intake. Paper presented at the 1<sup>st</sup> Regional Workshop on Evaluation of Smallholder Irrigation Development in Kenya. NARL, KARI, Nairobi. 8-11 November, 1999.
- Karanja, A.K. 1999. The Role of universities in irrigation development in Kenya. Paper presented at the 2<sup>nd</sup> Regional Workshop on Evaluation of Smallholder Irrigation Development in Kenya. Agricultural Resources Centre, Egerton University, Njoro, 8-11 December, 1999.
- Mbogo, R.N. 1999. The role of the ministry of environment and natural resources (DWD) in irrigation development in Kenya. Paper presented at the three Regional Workshops Workshop on Evaluation of Smallholder Irrigation Development in Kenya.
- NWMP (National Water Master Plan). 1992. *National water master plan*. Nairobi: Japan International Cooperation Agency and Ministry of Water Development.
- Oregó, F. 2000. SISDO experience on cost recovery in financing irrigation development in Kenya. Paper presented at the 3<sup>rd</sup> Regional Workshop on Evaluation of Smallholder Irrigation Development in Kenya. Museum View Hotel, Kisumu. 22-25 February, 2000.
- Seckler, D., D. Molden and R. Barker. 1998. *Water scarcity in the twenty-first century*. IWMI Water Brief. Colombo, Sri Lanka: International Water Management Institute.



# Water Scarcity and Conflicts: A Case Study of the Upper Ewaso Ng'iro North Basin

*Francis N. Gichuki*<sup>1</sup>

## **Introduction**

Growth in population, increased economic activity and improved standards of living have led to increased demand for freshwater resources in semiarid regions of Kenya. Consequently, local and regional water scarcity occurs in the dry seasons. It is induced mainly by low rainfall, low river flows, high demand for irrigation water and water pollution, and failure of water storage, delivery and distribution systems. With limited freshwater resources, competition for, and conflicts over, the resource use are increasing with increasing demand for water. The conflicts are further aggravated by high social inequity, economic marginalization and limited non-land-, non-water-dependent sources of livelihoods.

The purpose of this paper is to present a case study of water scarcity and associated problems in the Upper Ewaso Ng'iro North river basin in northern Kenya and to propose a research and action program through which the opportunities to alleviate water scarcity and associated conflicts can be exploited.

The Upper Ewaso Ng'iro North river basin is part of the Juba basin, which covers an area of 47,655 km<sup>2</sup> in Kenya, Ethiopia and Somali. The Juba basin has a low population density of 12 persons per km<sup>2</sup> and a high water scarcity, as 72 percent of the basin is in arid areas (WRI 1998). The Upper Ewaso Ng'iro North river basin is located to the north and west of Mt. Kenya (see figure 1) and extends between longitudes 36° 30' and 37° 45' east and latitudes 0° 15' south and 1° 00' north. The basin covers an area of 15,200 km<sup>2</sup>, approximately 6 percent of the Ewaso Ng'iro North drainage basin and 2.8 percent of the total area of Kenya (587,900 km<sup>2</sup>). The area falls under seven administrative districts (Nyandarua, Nyeri, Laikipia, Meru, Samburu, Isiolo and Nyambene) and three provinces (Rift valley, Central and Eastern).

The elevation gradient, climate and soil conditions give rise to ecological zones, ranging from humid to arid (see table 1). Approximately 60 percent of the area receives rainfall that is less than 50 percent of the potential evaporation.

The basin has been experiencing a high population growth arising mainly from immigration of small-scale farmers from the neighboring districts of Nyandarua, Nyeri and Meru and nomadic pastoralists from Baringo, Samburu and Turkana districts. In 1989, the population of the basin was estimated to be 270,000 (Karekia 1995). The population density varies with the ecological potential, access to water and available infrastructure. In 1989, population densities were estimated to be 875, 22 and 10 persons per km<sup>2</sup> for the Nyahururu division, a

---

<sup>1</sup>University of Nairobi, Kenya.

mainly urban area, the Rumuruti division, a mainly rural area with scattered smallholder settlements and the Mukogodo division, a rural area settled by pastoralists, respectively (Karekia 1995).

The Upper Ewaso Ng'iro basin is a rich wildlife ecosystem and is home to a large wildlife and livestock population as shown in table 2. Wildlife are generally found in national parks in Aberdare and Mt. Kenya, in private game ranches in the Laikipia plateau, in the game reserves in the lowlands, or in migratory areas as they move in search of water and grazing resources.

Figure 1. Location of the study area.

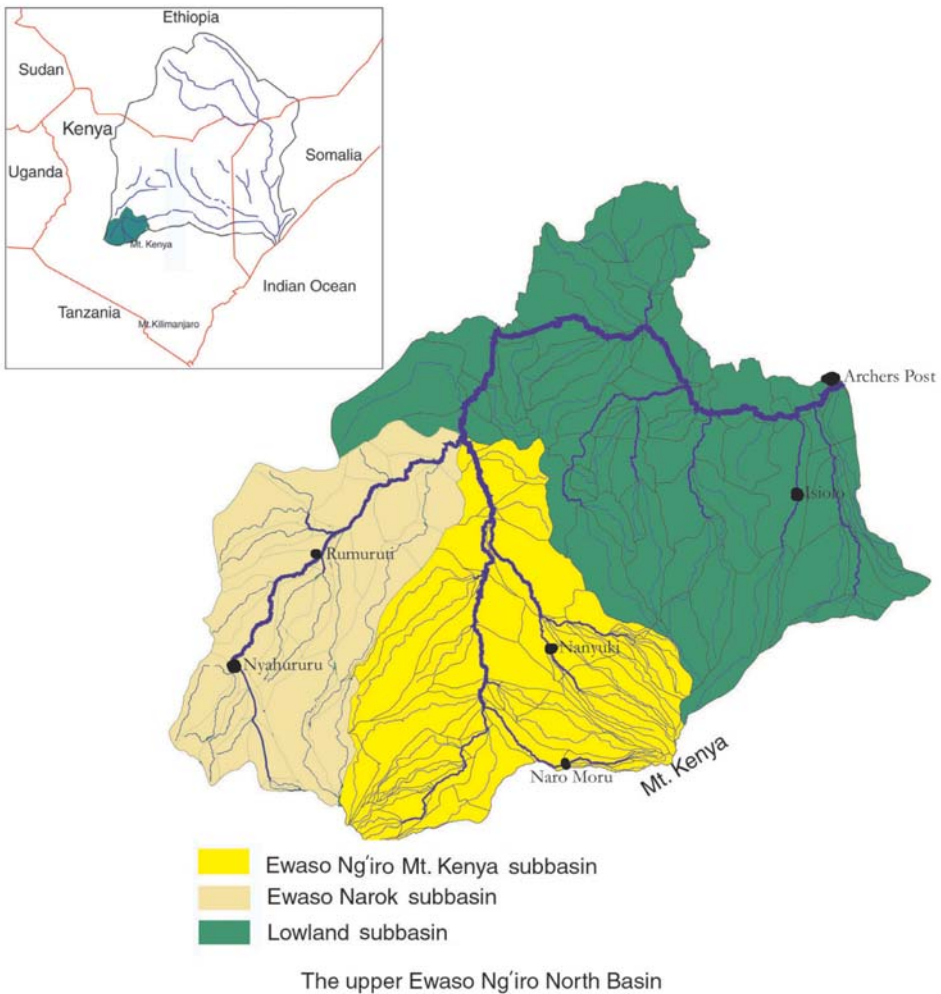

Table 1. Moisture availability zones.

Moisture Availability Zone	R/Eo	Classification	Natural Vegetation	Area (km <sup>2</sup> )	Total Area (%)
I	>0.8	Humid	Moist forest	358	2
II	0.65-0.8	Subhumid	Moist and dry forest	1,316	8
III	0.5-0.65	Semihumid	Dry forest and moist woodland	3,043	20
IV	0.4-0.5	Semihumid to semiarid	Dry woodland and bushland	3,046	20
V	0.25-0.4	Semiarid	Bushland	4,666	30
VI	<0.25	Arid	Bushland and scrubland	3,066	20

R = Average annual rainfall (mm); Eo = Average annual potential evaporation (mm); R/Eo = Moisture availability ratio.

Table 2. Summary of the animal population.

Species	1997		1990		1994		1997	
	PE	SE	PE	SE	PE	SE	PE	SE
Livestock	793,964	222,219	717,644	77,061	493,519	62,187	521,196	63,358
Wildlife	132,435	66,808	88,461	29,625	81,127	42,996	121,082	22,704

PE = Population estimate; SE = Standard error.

Source: Muchoki 1998.

## Status of Water Resources

*Rainfall.* The mean annual rainfall in the basin ranges from 1,500 mm in the montane forest areas of Mt. Kenya and Nyandarua mountain ranges to 350 mm in the arid lowlands around Archer's Post. The elevation and orientation of the major topographical features (Mt. Kenya, Nyandarua and Nyambene hills, and Mathews, Lariak, Marmamet and Ndundori ridges) influence rainfall distribution over the basin (figure 2). There are four seasons, namely: long rains, continental rains, short rains and dry season. The long rains (mid-March to mid-June) provide the best rainfall (29–40% of annual rainfall) over the entire basin. Continental rains (mid-June to mid-September) are mainly confined to the western edge of the basin and their importance diminishes as one moves north and east. Short rains (October to December) penetrate the basin from the dry northern region and contribute 50–60% of the annual rainfall of the arid areas. The continental rains falling in the southwestern parts of the basin are mainly credited for maintaining flows at Archer's Post from July to September when the other parts of the basin are relatively dry.

Long-term analysis of rainfall data shows high variability from year to year, particularly for low rainfall stations and wet-dry cycles of 5–8 years.



Figure 2. Rainfall distribution (annual mean).

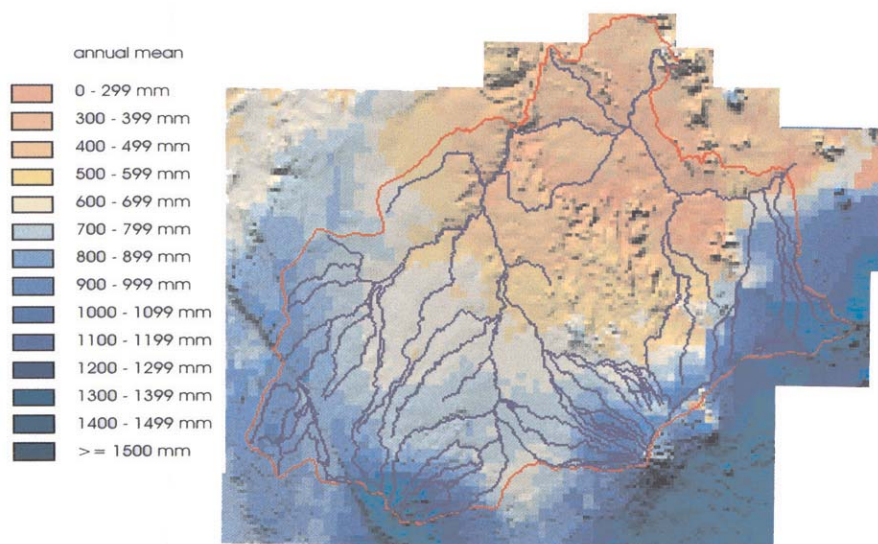

Source: Gichuki et al. 1998a.

*Surface water.* The Upper Ewaso Ng'iro North river basin can be divided into three main subbasins: the Ewaso Narok subbasin, the Ewaso Ng'iro-Mt. Kenya subbasin and the Ewaso Ng'iro Lowland subbasin. The common point of the three subbasins is the confluence of the Ewaso Narok and Ewaso Ng'iro rivers, called Junction. The relative contribution of the three subbasins to the river flow at Archer's Post varies with the rainfall regime (see table 3). An analysis of the relative contribution of the three subbasins shows the following (Gichuki et al. 1998b):

1. Ewaso Ng'iro-Mt. Kenya and Ewaso Narok subsystems with high rainfall and better ground cover (mainly the forested areas of Mt. Kenya and the Nyandarua mountain ranges) provide most of the water during the dry seasons.
2. The Mt. Kenya subbasin has the highest contribution during average rainfall and dry years<sup>2</sup> and for both wet and dry months.
3. The Ewaso-Narok subbasin sustains moderate flows at Archer's Post during the period of the continental rains (around June to September). Approximately 32 percent of the annual flow of the Ewaso Narok subbasin occurs during the months of June, July and August and an additional 36 percent occurs during the months of September, October and November.

<sup>2</sup>Glaciers of Mt. Kenya are important sources of water during the dry season.

4. The Ewaso Ng'iro Lowland subbasin has a major contribution during high rainfall periods (wet years and short-rain seasons) mainly attributed to the high runoff from the almost bare catchment at the beginning of the rains and the large area.

*Table 3. Sources of flows at Archer's Post.*

Period	Ewaso Narok Subbasin (5AC8) (3,380 km <sup>2</sup> )	Ewaso Ng'iro-Mt. Kenya Subbasin (5D5) (4,640 km <sup>2</sup> )	Ewaso Ng'iro-Lowland Catchment Subbasin* (7,180 km <sup>2</sup> )
1951 (wet year)	22	22	56
1952 (dry year)	18	75	7
1960 (average rainfall year)	11	67	22
April (wet month)	11	40	49
September (dry month)	59	41	0
November (wet month)	23	36	42
February (dry month)	28	69	3
Annual mean	30	46	24

*Sources:* MoWD 1992 and NRM<sup>3</sup> database 2000.

\*Catchment between Junction and Archer's Post.

Monthly flow data show that there is a high variability in flows with February having the lowest mean flow and November recording the highest mean flow (table 4). The analysis of river flow at Archer's Post from 1960 shows a clear trend of decreasing dry-season flow (figure 3). During the period 1960–2000, the maximum mean annual flow recorded was 82.36 m<sup>3</sup>s<sup>-1</sup> in 1961 and the minimum was 6.8 m<sup>3</sup>s<sup>-1</sup> in 1980 with a mean of 20.8 m<sup>3</sup>s<sup>-1</sup>. The 10-year running mean indicates that the flow has been decreasing since 1970. From April 1998 to December 2000, the daily mean flow peaked at 354 m<sup>3</sup>s<sup>-1</sup> in May 1998 and dropped to zero in February 1999 (Gichuki et al. 1999). River flow at Archer's Post gauging station is lowest in February and the mean for this month has dropped from 9 m<sup>3</sup>s<sup>-1</sup> in the 1960s, to 4.59 m<sup>3</sup>s<sup>-1</sup> in the 1970s, to 1.29 m<sup>3</sup>s<sup>-1</sup> in the 1980s, and to 0.99 m<sup>3</sup>s<sup>-1</sup> in the 1990s (Liniger 1995). The river dried up for a stretch of up to 60 km upstream of Buffalo springs in 1984, 1986, 1991, 1994, 1997 and 2000 (Gichuki et al. 1995; Gichuki et al. 1998b). This reduction in flow is attributed mainly to increasing water abstraction upstream and drought cycles, as there is no corresponding decline in rainfall amounts over the same period.

Table 4. Monthly flow characteristics at Archer's Post.

Month	Monthly Flow Parameters 1960–2000 ( $\text{m}^3\text{s}^{-1}$ )			
	Mean	Median	Standard Deviation	High Outlier Threshold
Jan.	11.82	4.25	17.76	181.73
Feb.	7.43	2.22	12.25	145.88
Mar.	10.28	5.59	13.40	142.06
Apr.	38.03	23.93	37.27	387.29
May	25.57	20.96	20.51	200.64
June	14.70	8.80	15.50	115.86
July	12.39	8.37	9.50	74.63
Aug.	16.95	13.13	13.53	141.85
Sept.	14.18	11.97	10.31	107.64
Oct.	17.65	12.82	15.74	212.96
Nov.	52.82	22.8	107.44	350.69
Dec.	28.12	12.16	36.47	273.67

Figure 3. Temporal variability of Ewaso Ng'iro river flow at Archer's Post.

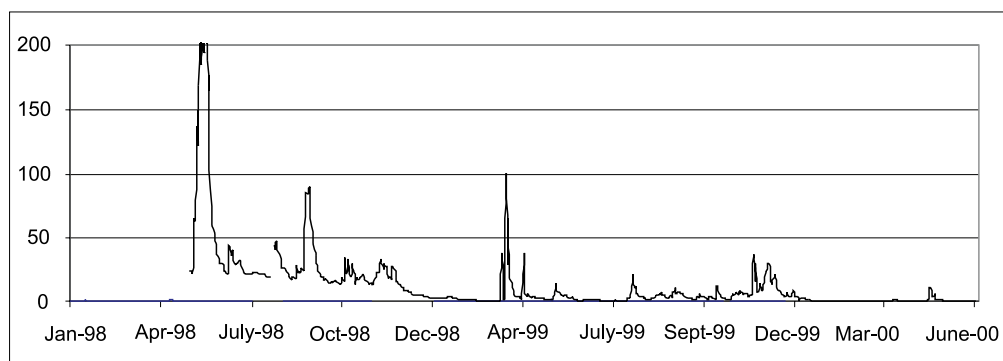
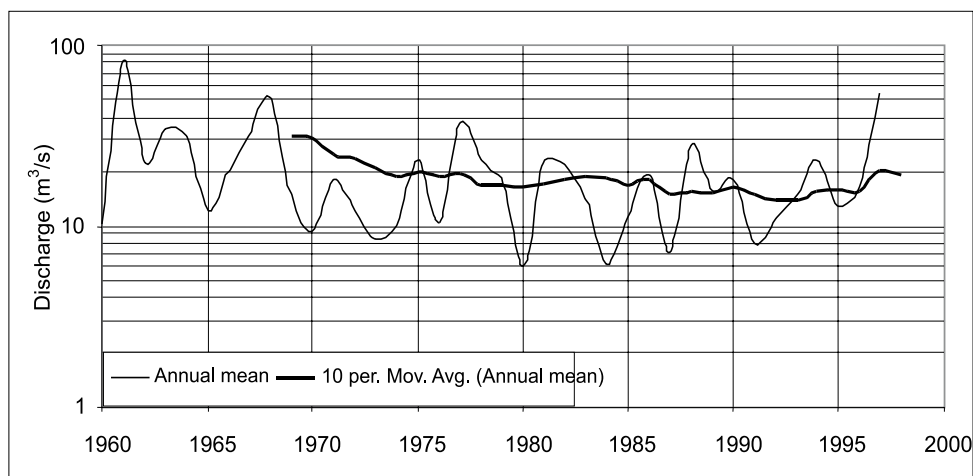

*Groundwater.* The total amount of groundwater replenished in the upper catchment is estimated to range between 120 and 220 million m<sup>3</sup> per year (MoWD 1987). Springs discharging the water in the riverine areas of the Ewaso Ng'iro river near Archer's Post (Buffalo<sup>3</sup> and Shaba springs) are an important source of dry-season flow for wildlife around the game reserve areas and for pastoralists downstream. Groundwater yield at points in the basin is associated with the hydro-geological properties of a given area and is highly variable with a static water depth ranging from 5.3 m to 96 m and the discharge varying from 0.3 m<sup>3</sup>/hr. to 13.7 m<sup>3</sup>/hr.

The distribution of boreholes in the basin is influenced by the availability of alternative water resources, groundwater potential,<sup>4</sup> economic activities of the area, and purpose and ownership of the borehole. In communal grazing areas, most of the boreholes are owned by the government as part of the program to improve access to water resources in areas with good grazing resources and limited surface water.

*Water quality.* Surface water is considered to have an acceptable quality for irrigation, livestock and domestic use in most areas. Decurtins (1992) quoted in Gichuki et al. 1998b reported that the Ewaso Narok river had very high concentrations of sodium and high electrical conductivity whose effect is moderated when the Ewaso Ng'iro merges with it. Therefore, it can be concluded that Mt. Kenya is a very important source of river water both in quantity and quality.

The limited availability of data on water quality shows that there are reasons for concern in some places, particularly during the dry season when the concentration of pollutants increases beyond acceptable levels. The main concerns of water quality are sediment loads, salinity, sanitation and sewerage, industrial waste and agricultural chemicals. Sediment is the major form of physical pollution. The Ewaso Ng'iro North river is reported to have a high suspended sediment load (1,538 ppm), the second highest rate of suspended sediment load of the major rivers in Kenya<sup>5</sup> (MoWD 1992). Studies on the suspended sediment load in ephemeral catchments show that the sediment load can be as high as 200 kg s<sup>-1</sup> at a flow rate of 4.4 m<sup>3</sup> s<sup>-1</sup> (Gichuki et al. 1995). The main source of biological pollution of surface water is sewage from major urban centers, namely: Nyahururu, Rumuruti, Nanyuki and Isiolo. The incidences of waterborne diseases are reported among community members who use Nanyuki river water downstream of the Nanyuki town, indicating possibilities of high levels of bacteriological pollution of the river water.

---

<sup>3</sup>Buffalo springs, on the southern bank of the river, yield approximately 0.20 m<sup>3</sup>/s to the Ewaso Ng'iro North river during the dry season. This source of water maintains flows at Archer's Post even when the Ewaso Ng'iro North river dries up about 60 to 80 km upstream of Archer's Post during the dry season.

<sup>4</sup>A recent project involved in the development of groundwater resources in the semiarid areas of the Laikipia district has reported a 63.7-percent success rate in striking water and equipping the boreholes.

<sup>5</sup>Suspended sediment load was reported as 3,387, 1,538 and 1,328 ppm for Perkerra, Ewaso Ng'iro North and Tana rivers (at Garissa), respectively.

## **Factors Leading to Declining River Flows at Archers' Point**

### ***Natural Factors***

The main natural factors contributing to the declining river flows at Archer's Post river-gauging station are seasonal rainfall pattern, low rainfall/high evaporation and drought cycles.

Since rainfall is the main source of streamflow, seasonal rainfall directly influences streamflow. The spatial variability of rainfall in the basin (see rainfall section) results in January and February being the months with no significant rainfall throughout the basin and hence with the lowest flow regime.

The average annual evaporation, rainfall and deficit (rainfall-evaporation) over the entire basin are 1,739 mm, 651 mm and 1,088 mm, respectively. Annual rainfall exceeds annual evaporation in only 1 percent of the basin area. A deficit of more than 1,000 mm per year is experienced, on average, on 51 percent of the basin area, whereas 11.5 percent of the area has a deficit exceeding 2,000 mm.

An analysis of data on rainfall and streamflow shows that extreme conditions of low flow are experienced during the dry seasons and in cycles of 2–8 years. A correlation analysis of rainfall and river discharges has shown that the decrease in low river flow is not a result of changes in rainfall patterns (Liniger and Gichuki 1994) but is due to a combination of low rainfall and high levels of water abstraction in the upper reaches. The drying up of the Ewaso Ng'iro North river upstream of Buffalo springs occurred following the low rainfall in 1983/84, 1985/86, 1991/92, 1994, 1997 and 1999/2000.

### ***Human-Induced Factors***

The main human-induced factors contributing to declining low flows at Archers' Post are land use and management, increasing water demand for human, wildlife and livestock use and inadequate management of water demand and supply.

*Land use and management-induced water scarcity.* Land use and management affect the partitioning of rainfall into runoff and infiltration that, in turn, affect the temporal and spatial availability of soil water, river water and groundwater resources. In forested areas, high rainfall, favorable soil drainage, and good canopy and ground cover result in high infiltration and groundwater recharge. Moderate evapotranspiration rates in these areas limit the amount of water lost to the atmosphere leaving most of the water to be released as dry-season river flow. Therefore, the forest belt is the most valuable water catchment area. In the semiarid highland plateau and arid lowlands, runoff induced by land degradation limits infiltration, groundwater recharge and dry-season river flows. Runoff losses as high as 60 percent have been recorded under poor ground cover conditions illustrating the importance of soil cover and topsoil management in water management (Liniger et al. 1998). Under these conditions, most of the rivers are ephemeral.

The main forms of land use changes experienced in the basin involve conversion from natural to plantation forest, from natural forest to cropland, from bushland to grazing land, from bushland to cropland, from grazing land to cropland, from grazing, forest or cropland to

residential, commercial or transportation-infrastructure land and from swamps and marshes to cropland. The most dramatic land use change is the conversion of grazing land to cropland in the Laikipia plateau by smallholder farmers, which was reported to be 25 percent between 1984 and 1992 (Liniger 1995).

Land management changes are made to facilitate intensification of land use and include irrigation, conservation farming (in-situ moisture conservation, contour farming, mulching, construction of structures for soil conservation and the use of cover crops), agroforestry,<sup>6</sup> plantation forest and cultivation of cleared forestland during the period of the plantation-tree establishment. These management changes are mainly geared towards increasing the productivity per unit area and, in some cases, result in higher water use thereby reducing the catchment water yield, particularly in semiarid areas. In humid and semihumid areas, these land management practices may lead to increased groundwater recharge, which ultimately improves river flows during the dry season.

The area where land use and management changes lead to improved dry-season river flows is small compared to where runoff has increased and, therefore, the net effect of these land use and management changes on water scarcity has been the decrease of river flow during the dry season (mainly the degradation of grazing land and increased water use by irrigated agriculture).

*Increasing water demand for human, wildlife and livestock use.* The human population has been reported to increase at 2–8 percent per annum in different parts of the basin and by 1989, the estimated population of the area was 270,000 (Karekia 1995). The total wildlife population in the lowlands in 1997 was estimated at 121,082, consisting mainly of buffaloes, eland, elephants, gazelles, impala, gerenuk and giraffes. The elephant population grew from 1,156 in 1977 to 5,391 in 1997. The increase in elephant numbers has a significant effect on water resources because their vegetation consumption affects ground cover and hence runoff. The livestock population in 1997 was estimated at 521,196, consisting mainly of cattle, sheep, goats, camels and donkeys (Muchoki 1998).

The projection of water demand in the year 2010, assuming 9,000 hectares of irrigated agriculture and 3 percent growth in the human population and the 1997 animal population, shows that the basin will experience serious water constraints (table 5). The densely populated area at the foot of slopes and on the Laikipia plateau, where population pressure has been increasing and where there is a high irrigation potential, will experience the highest water deficit.

*Inadequate management of water demand and supply.* There is a high dependency on perennial river water resources. Wiesmann (1998) noted that 75 percent of the rapidly growing population in the basin was concentrated in small-scale settlement areas where the demand for perennial river water has been increasing rapidly. In a household survey of the smallholder farmers, Wiesman reported that since 1964, rain, groundwater and perennial river-based water supply systems had increased (in number but not in volume of water supplied) by 11, 34 and 60 percent, respectively. Towards the end of the dry season, 88 percent and 93 percent of the

---

<sup>6</sup>Liniger et al. (1998) reported a fivefold increase in trees in cropland and a twofold increase in trees in grazing land within an 8-year period (1984–1992).

Table 5. Subbasin water balance for the year 2010.

Subbasin	Area (km <sup>2</sup> )	Potential (m <sup>3</sup> /day)		Demand in 2010 (m <sup>3</sup> /day)		Potential Demand in 2010 (m <sup>3</sup> /day)	
		Surface water	Ground- water	Domestic and livestock	Irrigation water requirement	Domestic and livestock	Domestic livestock and irrigation
5AA	560	1,728	1,321	14,601	35,000	-11,552	-46,552
5AB	482	2,592	455	15,434	65,000	-12,387	-77,387
5AC	1,879	3,802	1,744	24,525	59,000	-18,979	-77,979
5AD	517	1,037	907	5,731	35,000	-3,787	-38,787
5BA	269	12,960	125	4,144	80,000	8,941	-71,059
5BB	452	39,744	461	4,061	90,000	36,144	-53,856
5BC	1,636	45,792	2,824	16,800	120,000	31,816	-88,184
5BD	674	17,280	805	6,760	53,000	11,325	-41,675
5BE	1,238	4,320	2,636	10,456	150,000	-3,500	-153,500
5DA	2,240	108,000	8,306	20,102	90,000	96,204	6,204
5DB	1,176	132,192	3,579	2,921	25,000	132,850	107,850
5DC	1,268	175,392	2,894	8,419	14,000	169,867	155,867
5DD	1,883	134,784	5,553	18,392	16,000	121,945	105,945
5DE	926	3,900	450	5,289	70,000	-939	-70,939
Total	15,200	683,522	32,060	157,635	902,000	557,948	-344,052

households are dependent on river water in the semihumid and semiarid zones, respectively. These values underline the importance of perennial rivers as water sources and the growing pressure on these resources during the critical dry-flow conditions. The main reasons for the high dependency on the perennial river water resources are: a) reliability; b) accessibility; c) ease of capture and conveyance to the point of use, as they require the least technical and material input during construction and operation; and d) nonexistent or too expensive alternative sources of water.

There is also water scarcity induced by the abstraction of irrigation water. High levels of water abstraction in the upper reaches of the Ewaso Ng'iro have been blamed for decreasing water availability in the lower reaches. Overabstraction in the upper reaches of the river has been taking place since the introduction of irrigated agriculture in the area but it has increased at an exponential rate since 1984 when production of horticulture crops for the export market became very profitable. There is a higher level of abstraction in the upper reaches mainly due to the hydraulic and hydrologic advantage, suitability for irrigation development, access to the market and the settlement density. During the dry season, irrigation water demands and economic loss for not irrigating a water-stressed crop are highest. Consequently, as much as 60–80 percent of available water in the upper reaches is abstracted, 40–98 percent of it being unauthorized (Gikonyo 1997). Unauthorized abstractions are mainly attributed to a) lack of an effective abstraction-monitoring program, b) high financial returns from irrigated agriculture and low fines for illegal abstractions, c) lack of storage facilities for floodwater; and d) low water-use efficiency as evidenced by low irrigation efficiencies (25–40%) of smallholder irrigation schemes (Gichuki 2000).

There is potential for untapped water storage. Where there is inadequate ground cover most of the rainfall runs off whereas retaining only 30 percent of the current runoff can triple the available water supply (Gichuki et al. 1998b). Most parts of the basin have a high potential for water harvesting (surface or roof catchment) and storage (above and below ground tanks). Experience has shown that the use of underground water tanks, as a source of supplemental irrigation water, enables farmers to grow vegetables during the dry season and recover their investments in 2–4 years. The potential for small earth dams exists on many ephemeral and perennial springs. This potential if exploited would minimize the dry-season water abstraction from the perennial rivers. Suitable sites for large- and medium-scale reservoirs have also been identified but none has been developed (Gichuki 1999).

## **Conflicts Associated with Water Scarcity**

### *Conflicts and Key Actors Associated with Water Scarcity*

Conflicts in the basin have arisen due to a number of reasons: ethnicity, clanism, finance, gender, water scarcity, inequitable water allocation and distribution, election of representative water users, failure to observe water bylaws, imposition of values by outsiders, etc. In this paper, the focus is on conflicts induced by water scarcity. Water scarcity, particularly in the lower reaches of major rivers, has been increasing over the years and has resulted in conflicts. Box 1 presents a summary of some of the conflicts that have been reported in the basin. The effects of conflict vary from temporary reduction in water availability to complete collapse of water-supply projects. In some cases, conflicts have escalated into physical violence.

Water-related conflicts occur in the basin at the following levels: among water-project beneficiaries (project level); between different water-user groups (upstream v downstream); and between water users and environmentalists/resource managements (use v conservation). Project-level conflicts occur within a water project where the water-project beneficiaries are the key stakeholders. Conflicts at this level arise from inequitable water allocation and delivery, financial mismanagement, disputes over the unfair distribution of maintenance work, failure to observe bylaws, etc. Conflicts between upstream and downstream occur between irrigation and nonirrigation water users, mainly over very low dry-season river flows. Conflicts at this level arise from overabstraction of water by upstream water users, pollution of water, lack of cooperation between different user groups, disputes generated by jealousy related to growing wealth disparities, and conflicts between indigenous resource users and recent settlers. Use v conservation conflicts occur between those benefiting from direct use of water and those benefiting from environmental functions (e.g., tour operators/hoteliars operating in the basin). Conflicts at this level arise from environmental degradation associated with the drying up of the lower reaches of the river, migration of wildlife to upper reaches in search of water and grazing resources and associated loss of income.

The key actors in these conflicts fall into the categories of active or passive parties. They include environmentalists, small- and large-scale irrigators, nomadic pastoralists and commercial ranchers, downstream hoteliers and tour operators and downstream communities (living below the Archer's Post).



*Box 1. Intensity of water conflicts.*

*Downstream Water Users Versus Conservationists Calling for Reduced Destruction of Forested Water Catchments*

One of the main causes of water problems has been identified as destruction of water catchment areas. Newspapers are replete with statements on the effect of the wanton destruction of the water catchment. For example, on 26 February, 1999, the Managing Director of Tana and Athi Rivers Development Authority was quoted by a Daily Nation reporter as saying that “Kenya faces an imminent water deficit attributed to the massive destruction of water catchment areas. There is a lot of clearing of catchment areas that must be curbed.” On 3 December 1999, another Nation reporter said that 5 persons had died and many houses, household goods and crops washed away following flash floods in unprotected water catchments. On 15 March 2000, Namunane attributed water scarcity to massive felling of trees in water catchment areas. He quoted a former minister as saying “parts of his Nyeri district that were once wet and lush all year-round, have rapidly turned into semiarid areas requiring food relief.”

*Sources:* Daily Nation. Issues on 26 February and 23 December 1999, and 15 March 2000.

*Conflicts between Smallholder Irrigators and Smallholder Farmers*

On 21 February 2000, residents of the Kariminu village led by the Chairman of the Nyeri County Council barricaded the Nyeri-Nyahururu highway from 8.30 a.m. to 1.00 p.m. when the police arrived at the scene. They were protesting against the diversion of the Kariminu river by a group of individuals for irrigation and failure of the local District Officer and District Water Office to take any action to stop the illegal abstractors from draining the river. They claimed that their sub-location had gone without water for several months due to overabstraction by upstream irrigators resulting in increases in typhoid cases and near closure of a local boarding high school. They demanded audience with the area District Commissioner. As the riot police were restoring law and order, a riot erupted and several vehicles were damaged and old men and women who could not flee were injured.

*Source:* Wachira 2000.

*Box 1. (Continued).*

*Conflicts between Irrigators and Pastoralists*

Mathenge (2000a) reported that NGOs working with pastoralists were expressing concern over unbalanced exploitation of water resources, which cause serious conflicts. They argued that the benefits accruing from horticultural farming should not be allowed to continue at the expense of denying water resources for pastoralists. They blamed small- and large-scale irrigators for the drying of the Nanyuki river barely 20 km from the Nanyuki town. They criticized the government for failing to enforce the Water Act.

*Conflicts between Irrigators and Fish Farmers*

On 13 March 2000, a Daily Nation correspondent reported that a Nanyuki fish farmer had lost 30,000 trout following the diversion of the Likii river for irrigation upstream. The loss was estimated at KSh 4 million (US\$53,000). This is an example of the water availability risks that are borne by downstream water users.

*Source:* Nation Correspondent 2000a.

*Human-Wildlife Conflict*

On 21 March 2000, a Daily Nation correspondent reported that 10 villagers of the Takaba Trading Centre, Mandera district, were hurt and 8 monkeys killed in a 2-hour battle between man and beast over water. The trouble started when monkeys attacked villagers, while the latter were drawing water from three relief water-delivery tankers. The clawing and biting monkeys sent villagers fleeing and then took to quenching their thirst. The villagers regrouped and counterattacked and killed eight monkeys. The villagers reported that water shortage in the area had forced gazelles, hares and monkeys out of the bush to roam through the villages. They feared that the more dangerous animals, such as elephants, lions and leopards would soon attack them in search of water.

On 23 March 2000, Mathenge (2000b) reported that elephants had left the wild to look for water in a village watering point in the Olborsoit location of the Laikipia district. Approximately 4,000 pastoralists and their cattle were experiencing water shortage and were forced to move upstream in search of water and grazing resources.

*Source:* Nation Correspondent 2000b.

### ***Why Are Conflicts Interesting?***

Conflicts over water resource use result from competition for water resources mainly during the dry season and the presence of deep-seated latent conflicts. Conflicts associated with water scarcity are attributed to overabstraction of water in the upper reaches, land use and management-induced changes in flow regimes resulting in decreased low flows, water pollution and to prolonged drought conditions. Latent conflicts are attributed to inequalities inherent in social, cultural, racial, economic and political disparities among the stakeholders. Latent conflicts include perceived inequitable access to water and land resources, economic and political elites supporting commercial interests over and above those of the local groups, and longstanding ethnic, cultural, racial, political and economic differences. Latent conflicts are generally dormant until “reawakened” by scarcity and/or inequitable allocation of the scarce resource, mainly during periods of drought. These conflicts are intensified by institutional failure to achieve fair and equitable water management and water users’ perceptions and attitudes as illustrated below.

*Weaknesses in water allocation.* The current water allocation procedure lays a lot of emphasis on issuance of water use permits.<sup>7</sup> These permits may be acquired for domestic use, public water supply, minor irrigation (<0.8 ha), general irrigation (>0.8 ha), industrial use and power generation. They are issued by the Water Apportionment Board upon recommendations of the Ewaso Ng’iro North Catchment Board, District Water Boards and the Water Bailiff in charge of the river reach where water is to be abstracted. The current water allocation procedures have the following limitations that constrain the attainment of fair and equitable allocation of water resources:

1. Inadequate information on the availability of water resources, permitted abstraction and reserved flows for future applicants.
2. The concepts of flood and low flow are not generally applied in assessing water availability for the reach from which water will be abstracted.
3. There are no limits set on how much water can be abstracted in different reaches of the river system, or on district water abstraction quotas. This leads to overallocation of water resources in the upper reaches of the rivers.
4. It takes a long time (6 months to 2 years) between the application of a water permit and the award of the permit during which time applicants continue to abstract water.

---

<sup>7</sup>The government owns the water resources of the country and the right to use them is vested in the relevant Minister but this right may be acquired in accordance with the stipulations of the Water Act.

*Weaknesses in water abstraction policing.* All water users abstract water illegally at one time or another. The main difference is in the nature and extent of the illegal abstraction. Illegal abstraction is considered to take place when the water is abstracted by a user without a permit<sup>8</sup> or when more than the authorized amount is abstracted at a particular time.<sup>9</sup> Weaknesses in water abstraction policing are attributed to a) inadequate budgetary and human resources allocated for this task, b) lack of clear guidelines and information on legal abstractors for when to and at what flow rate water is to be abstracted (water permits specify water to be abstracted in term of m<sup>3</sup>/day rather than l/s), c) lenience to poor farmers, d) political patronage, and e) lack of complainants (most downstream water users raise concerns only during severe droughts).

*Water users' practices, perceptions and attitudes.* Over the years, water management has been greatly influenced by people's perceptions and attitudes. Illegal abstraction of water resources started in the 1940s and was influenced by the attitudes of European farmers.<sup>10</sup> They argued that water should be put into more productive use in the upper reaches rather than go to waste in the lower reaches. Ironically, after more than 50 years, practices and attitudes today have not changed due to the following perceptions of upstream abstractors:

1. They are only abstracting a small percentage of the flow, which has little or no impact on downstream water users.
2. Downstream water uses are of low economic benefit and, hence, generally, water goes to waste.
3. Changing the current water abstraction patterns calls for investments, which are costly and unjustifiable to upstream water users.

---

<sup>8</sup>This may take the form of abstracting water after submitting an application, or after getting approval to construct abstraction works or abstracting using the previous landowner's permit or abstracting pending approval or renewal of the water permit.

<sup>9</sup>This may take place in the form of abstracting water during low flow conditions whereas the permit is for abstracting water under flood and/or normal flow conditions.

<sup>10</sup>Many furrows have been made without permission of the Water Board (actually, they have been made in open defiance of it). They are not lined with cement (nor is the quantity measured) and, in many cases, the water is allowed to run waste in the bush instead of being returned to the river, as it should be, so that what remains of it can benefit the natives living down in the North Frontier Districts (NFD) (Ferson 1948, 279, quoted in Mathuva 1997).

A remark you hear from many of these settlers is "why the hell should the natives have it? (ibid.)

... in a place where water was supposed to be measured, (a farmer) was taking seventeen times the amount of water that was allowed to him: ... I mentioned this to Reece, who was fighting to bring down all the water that he could for the natives of the NFD. He smiled, albeit bitterly, and said that such men should be shot. My opinion is that those who deserve shooting are the people who permit it (Mathuva 1997).

## Emerging Issues and Implications for Research

### *Emerging Issues*

*Water users' perceptions and their effect on water management.* Water stakeholders have diverse perceptions of the availability of water resources, water scarcity and conflicts, and solutions (see box 2). Interventions that will strengthen the ability of different groups to engage in informed dialogues on the problems, the underlying causes, solutions and strategies to address the problems are very important in addressing water management problems at all levels. Therefore, there is a need to a) improve public access to key information on water resources, b) provide a framework for widespread public involvement in decision making in water management, and c) develop analytical and advocacy capacity, which can synthesize water data into information required for influencing informed water-management decision, and guide water-management initiatives.

#### *Box 2. Commercial irrigators' views on water-resource conflicts.*

There is a growing perception that irrigated horticultural enterprises are abstracting too much water and consequently having an adverse impact on smallholder irrigators and downstream pastoralists. Commercial irrigators operate under conditions of uncertainty of weather, water availability and market conditions. They also have to take into consideration that the Water Bailiff may ban irrigation altogether on short notice, which could result in huge financial losses arising from nonproduction of irrigated crops and consequently failure to honor delivery contracts. This discourages long-term investments in irrigated commercial agriculture.

Commercial irrigators have to maintain irrigation throughout the growing cycle irrespective of the conditions of the river flow. Provision of storage and, in some cases, exploitation of groundwater are both a statutory obligation and an economic necessity for them. Commercial irrigators view smallholder irrigators as inefficient irrigators. They use inefficient water delivery, distribution and application methods, use poor agronomic practices and consequently get a very low return per unit volume of water abstracted. They argue that substantial savings of water can be made if smallholder irrigators were to substantially improve their water-use efficiencies.

*Source: Gichuki and Njeru 2000; and Fox 1998.*

*Need for better water allocation mechanisms.* The system of allocation of water resources in the basin evolved in 1963 when a fixed allocation per unit length of river frontage was applied, to allocation on the basis of an application and availability of water resources. Downstream requirements are taken into consideration by estimating water requirements of the downstream water uses and by allocating only floodwater for irrigation, leaving the normal and low-flow water resources for domestic, livestock and industrial uses and for meeting environmental streamflow requirements. Although there is provision for local-level involvement in water allocation, the process is predominantly top-down with most of the decisions being made at the highest levels (Kiteme and Mathuva 1995; Mathuva 1997). This creates room for discontent and lays the foundation for conflicts as water scarcity bites.

In the past, downstream water uses were minimal and, hence, most of the water resources were allocated for use in the upper reaches. The situation is changing with the downstream users demanding a say in the way the water resources are shared (see box 1 for conflicts between pastoralist and upstream users). Therefore, there is a need for integration of views and interests of various sectoral and stakeholders, with due attention given to upstream-downstream relationships in the water allocation decision-making process.

*Need to look at the bigger picture.* Water scarcity and associated conflicts have been compounded by the lack of a good understanding of the nature and extent of water shortage, failure to take action required to address water-scarcity issues, inequity in resource access, poverty, lack of alternative sources of livelihood, high cost of water development and technologies that use water efficiently, political interference, diverse perception on water availability and entitlement to use, gap between the rich and the poor, etc. These perceptions bring out disagreements among the stakeholders on the causes and the course of action to be taken to address the problem. Hence the need to look at the bigger picture so as to be able to address political and economic disparity and social factors contributing to disputes and disagreements.

*Need for better conflict-management mechanisms.* As the conflicts continue to intensify there is a need to develop capacity in conflict management.<sup>11</sup> Conflict management strategies should build on the existing mechanisms, such as enforcement of the Water Act and relying on the self-regulating capacity of the stakeholders within the limits of the Water Act (GoK 1999). Capacity building would include training conflict management team members who would consist of trainers, facilitators, mediators or arbiters and developing guidelines on conflict management. Resolving conflicts requires that the issues related to factual disagreements, conflicting goals and relational aspects are addressed (Mostert 1998).

---

<sup>11</sup>Conflict management is guiding conflicts towards constructive rather than destructive results. It is a process that promotes dialogue and negotiation by a) addressing issues of disagreements before they generate hostility, b) helping different actors to explore various options for minimizing conflicts and to select those that are widely acceptable and that everyone can live with, and c) identifying the underlying causes of conflict and addressing them with a view to preventing them in future (Babbit et al. 1994).

*Getting the facts right.* Disagreements on water resources are often attributed to the following:

1. The facts on any water resources situation are dynamic and the situations are hardly ever totally certain.
2. Uncertainties arising from imperfect knowledge of the functioning of water systems, limited representativeness and reliability of data and the use of assumptions as a substitute for knowledge and data.
3. The fact that different interest groups often have different data and information sources.
4. Limited capacity to process and use information in ways that will eliminate misunderstanding.
5. Distortion of facts as a tactic to oppose certain actions (Mostert 1998).

Disagreements over the availability of water resources, levels of water use and the impacts on downstream water users are the major causes of conflicts among upstream and downstream water users in the basin. These disagreements can be addressed by developing an effective communication mechanism to ensure that all the parties share the same data and information.<sup>12</sup> Efforts are under way to initiate collaborative monitoring of river water flows and abstractions with the WUAs. It is hypothesized that by involving the WUAs in streamflow monitoring, they will get a better appreciation of the flow regime and water scarcity.

*Minimizing conflicting goals.* Conflicting goals arise when the resources use is viewed from different users' perspectives. Conflicting goals in the basin manifest themselves in the use of water for irrigation in the upstream reaches versus using the water to support the wildlife ecosystem and pastoralism in the lower reaches. Even where the goals are not conflicting there may be conflicts over the approaches to use in arriving at the common goals. A case that is generally put forward is that the water resources should be used to alleviate poverty and promote food security. Upstream water users give high priority to using the resources in the upper reaches of the river where, they argue that, their water use efficiency is higher and results in producing food more efficiently, making it affordable to the downstream water users who are mainly engaged in less water-demanding sources of livelihoods.

---

<sup>12</sup>For all the parties to agree on the data and information to be used in addressing the conflict, it is necessary that they develop confidence in the data sources. This can be achieved by a) active participation of all parties (in person or through their knowledgeable representative) in monitoring and research and in drawing conclusions, b) monitoring and research undertaken by a third party, acceptable to all parties, c) one party (or its representative) undertakes the monitoring and research and the other parties accept the results if they do not detect any biases or if they do not have the resources to question the results or if they can live with the negative aspects of the decisions arrived at using the results of the study.

Conflicting goals can be addressed by searching for “win-win” solutions in which all parties are better off than under the present situations. “Win-win” solutions can be created by means of compensation in kind and by financial or other management and/or policy interventions. For example, it may be worth exploring compensating upstream water users to improve their water use efficiency and consequently release more water for downstream users.

### ***Addressing Issues of Distrust and Power Struggle***

Relational aspects such as distrust and power struggles are important factors in resolution or escalation of water conflicts. Mostert (1998) argued that power struggles can start out of distrust and out of a feeling that the other party wants to increase its power or when the party starting the struggle thinks that it can increase its power. In the upper Ewaso Ng’iro North basin, distrust exists among the interest groups particularly when racial and tribal dimensions are taken into consideration. Power struggles among different communities and water users in the same water project have led to intensification of conflicts over water use (Gichuki 2000)

### ***Research Implications***

Research is required to provide answers to the following questions:

1. What are the economic and social losses arising from conflicts associated with water scarcity? What are the economic and social benefits of different technologies for improving water-use efficiencies? What mechanisms are needed to persuade upstream water users to invest in increasing their water use efficiencies thereby reducing the amount of abstraction of river water?
2. What is the value of the ecological functions performed by water and what is the minimum quantity and flow rate for this purpose? What are the benefits of environmental and ecological services of allocating land and water resources to fishing, grazing and forestry, and how can they be shared equitably?
3. How can water resources be allocated among different subbasins and districts? How should water resources be allocated among different water uses and users to ensure that we maximize productivity of water resources and equity, and reduce water-related conflicts?
4. How can policy and institutional constraints be alleviated? What water tariffs should be imposed on abstractors of irrigation water at different flow regimes? What is the optimal mix of direct regulation and self-regulation under different levels of water scarcity and different levels of conflict? What institutional arrangements are required at different levels?

This research calls for development of tools to address these questions and requires integration of social, economic, hydrologic and ecological principles and multidisciplinary research.



## Conclusions

Water scarcity and associated conflicts arise because there is a) insufficient water, particularly during the dry seasons, b) inadequate water storage to reduce dependency on dry-season flows, c) inefficient use of water resources, d) diverse perceptions of water availability and inequity, e) inadequate enforcement of water laws, f) water user perceived gains and losses arising from use or nonuse of water, and g) lack of information on the downstream water situation and associated impacts. Under conditions of conflict, efficient water management is crucial to maximize benefits and spread them as widely as possible. An important prerequisite of this is availability of data to understand and interpret the hydrological characteristics of the area.

The government has played a key role in promoting sustainable water management through its policy on water-resources management, legislation and institutional roles. However, due to lack of political will and adequate budgetary provision for implementing policies and enforcing legislation, water scarcity continues to bite. During extreme drought years this translates into conflicts between upstream and downstream users. Consequently, the potential of water resources to alleviate poverty and to promote social and economic growth and prosperity has not been achieved.

The importance of creating an enabling framework for equitable, efficient and productive use of water resources in the basin cannot be overemphasized. It has, however, become evident that water stakeholders will have to play a key role in creating the enabling framework for action. Involvement of stakeholders, capacity building, a sound information base and conflict-resolution mechanisms are the key elements to addressing water scarcity and associated conflicts in the basin.

## Literature Cited

- Babbitt, E.; P. Gutlove; and L. Jones. 1994. *Handbook of basic conflict resolution skills: facilitation, mediation and consensus building*. Massachusetts, USA: The Balkans Peace Project, Cambridge.
- Daily Nation Correspondent. 2000a. *Fish die as river is diverted*. Nairobi, Kenya: Daily Nation article, 13 March 2000.
- Daily Nation Correspondent. 2000b. *Monkeys, humans fight over water*. Nairobi, Kenya: Daily Nation article, 21 March 2000.
- Fox, R. H. 1998. A commercial horticultural grower's view point. Paper presented at the international conference on research, planning and conflict resolution for sustainable use of natural resources of the Mount Kenya and the Upper Ewaso Ng'iro North basin held at Nanyuki, 8-16 September 1998.
- Gichuki, F. N. 2000. *Community water management: The case of Matanya small-scale irrigation scheme, Laikipia district, Kenya*. NRM<sup>3</sup> project report.
- Gichuki, P. G. 1999. Flow regulation: A case study of the Upper Ewaso Ng'iro North River. M.Sc. thesis, University of Nairobi. Duplicated.
- Gichuki, F. N.; P. G. Gichuki; R. K. Muni. 1999. Characterisation of the flow regime of Ewaso Ng'iro North River. *East African Agricultural and Forestry Journal* 65 (1).
- Gichuki, F. N.; H. P. Liniger; L. MacMillan; G. Schwilch; and G. Gikonyo. 1998b. Scarce water: Exploring resource availability, use and improved management. In Resources, actors and policies—towards sustainable regional development in the highland- lowland system of Mount Kenya. *Eastern and Southern Africa Journal* 8 (15–28). Special Issue, Nairobi.
- Gichuki, F. N.; H. P. Liniger; and G. Schwilch. 1998a. Knowledge about highland-lowland interactions: The role of a natural resource information system. In Resources, actors and policies—towards sustainable regional development in the highland-lowland system of Mt. Kenya. *Eastern and Southern Africa Journal* 8 (15). Special Issue. Nairobi.
- Gichuki, F. N.; and J. L. Njeru. 2000. *Water stakeholders meeting: Towards water management action plans. Proceeding of a water stakeholders meeting held in Nanyuki, August 17-18 2000*. NRM<sup>3</sup> report.
- Gichuki, F. N.; M. K. Thomas; and P. G. Gichuki. 1995. *Status of water resources of the Upper Ewaso Ng'iro North river basin*. NRM<sup>3</sup> project report. In *Proceedings of the water managers and administrators workshop on sustainable use and management of water resources in the Upper Ewaso Ng'iro North basin held at the Mountain Rock Hotel, Nyeri, from 29 September to 3 October 1996*, ed. J.M. Mathuva.
- Gikonyo, J. 1997. River water obstruction monitoring for the Upper Ewaso Ng'iro river basin, Kenya. Paper presented at the SPPE workshop, Madagascar, 2-6 June 1997.
- GoK (Government of Kenya). 1999. *Sessional paper no. 1 of 1999 on national policy on water resources management and development*. Nairobi: Government Printer.
- Karekia, J. N. 1995. Background information of the ENNDA region. Paper presented at the seminar on sustainable resource management in the ENNDA region held at Sarova Shaba Game Lodge, Isiolo from 28 November to 1 December 1995.

- Kiteme, B. P.; and J. M. Mathuva. 1995. Proceeding of the policy makers and facilitators on water use and management in the Ewaso Ng'iro North river basin, held at Aberdares Country Club, Nyeri, from 20 to 22 February, 1995. Nanyuki, Kenya.
- Liniger, H. P. 1995. *Endangered water—A global overview of degradation, conflicts and strategies for improvement*. Development and Environment Report No. 12. Lang Druck AG. Bern, Switzerland: Centre for Development and Environment.
- Liniger, H. P.; and F. N. Gichuki. 1994. *Simulation models as management tools for sustainable use of natural resources from the top of Mount Kenya to the semi-arid lowlands*. Laikipia-Mt. Kenya Paper, D19. Nanyuki and Nairobi
- Liniger, H. P.; F. N. Gichuki; G. Kironchi; and L. Njeru. 1998. Pressure on the land: The search for sustainable use in a highly diverse environment. *East and Southern Africa Geographical Journal* 8.
- Mathenge, G. 2000a. *NGOs to meet over water resources*. Daily Nation article, 13 March 2000.
- Mathenge, G. 2000b. *The river of god has amazingly dried up*. Daily Nation article, 23 March 2000.
- Mathuva, J. M. 1997. Proceedings of the water managers and administrators workshop on sustainable use and management of water resources in the upper Ewaso Ng'iro North basin held at the Mountain Rock Hotel, Nyeri, from 29 September to 3 October 1996.
- Mostert, E. 1998. A framework for conflict resolution. *Water International* 23(4):206-215. The Netherlands.
- MoWD (Ministry of Water Development). 1987. *Water resources assessment study in Laikipia district*. Nairobi, Kenya: Government of Kenya.
- MoWD. 1992. *Water resources development and use plan towards 2010*. Vol.1 of National Water Master Plan. Nairobi, Kenya.
- Muchoki, C. 1998. Vegetation dynamics and land use in Ewaso Ng'iro basin, Kenya: A basis for natural resources management. Report submitted to Rockefeller Foundation.
- Namunane, B. 2000. *Massive tree-felling threatens catchment areas in mountains: Water shortage worsens*. News Feature article, Daily Nation, 15 March 2000.
- Wachira, M. 1999. *Wanton destruction of water catchments*. Daily Nation article, 23 December 1999.
- Wachira, M. 2000. *Protest at diversion of river*. Daily Nation article, 23 February 2000.
- Wiesmann, U. 1998. *Sustainable regional development in rural Africa: Conceptual framework and case studies from Kenya*. African Studies Series A14. Berne, Switzerland: Geographica Bernensia.
- WRI (World Resources Intitute). 1998. *Chapter 12: Freshwater resources and withdrawals*. Web data. <http://www.wri.org/wri/wr-98-99>.

# Links Between Land Management, Sedimentation, Nutrient Flows and Smallholder Irrigation in the Lake Victoria Basin

*Chin Ong<sup>1</sup> and Frederick Oregu<sup>2</sup>*

## **Abstract**

Over the last few decades, sedimentation and nutrient runoff, urban and industrial point-source pollution and biomass burning have induced rapid eutrophication of Lake Victoria. Recent studies indicate that severe erosion and land degradation are responsible for about half of the nutrient load into the lake. In western Kenya, the sedimentation of the Nyando river has negatively affected the performance and sustainability of several irrigation schemes, which were converted from natural wetlands. These wetlands have important filter functions, which are critical for the viability of the irrigation schemes as well as for the ecology of the lake. The last 20 years have witnessed a high rate of conversion of wetlands into irrigated agricultural land, reaching an area of over 6,500 hectares in the Nyando river basin. However, a sizeable portion of the reclaimed area is rapidly reverting to swamps due to a multitude of reasons, the most prominent being sedimentation. The long-term future of these irrigation schemes is bleak unless the high sediment load in the Nyando river is controlled. Several interventions to prevent the lateral flows of water, sediments and nutrients from the landscapes into the lake are described.

## **Introduction**

Irrigation schemes in the Lake Victoria basin are mainly derived from wetlands. Wetlands are lands characterized by water saturation, which determine the nature of soil development and the type of plant and animal communities living in the soil and on the surface. Such lands are unsuitable for agriculture because the conditions for plant growth, cultivation and any undertaking of other activities related to crop production are not ideal. With an estimated 2.6 percent annual growth rate in world population (Ritzema 1994), the greatest challenge facing the world today is meeting the needs of food and wood for the ever-growing population, predominantly in developing countries. In addition to inappropriate technology, the scarcity of both water and agriculturally productive land is the main obstacle to be overcome to produce

---

<sup>1</sup>International Centre for Research in Agroforestry, P.O. Box 30677, Nairobi, Kenya.

<sup>2</sup>Freelance consultant, Irrigation and Water Management, P.O. Box 29082, Nairobi, Kenya.

enough food to satisfy demand. Therefore, wetlands are increasingly drained and converted for agricultural purposes (Maltby 1986).

Wetlands play an important role in the ecosystem. They absorb and slow downstream flow, filter and remove sediments and degrade pollutants. They are highly productive systems with a high nutrient-fixing ability. The key to good filtering is related to the retention time of water in the wetlands; the longer the water takes to evaporate and infiltrate the longer it takes nutrients to be absorbed by plants. Wetlands provide a good source of plant material for local economies and are recognized for their biodiversity and wildlife functions. Wetlands also have variable efficacies dependent on the conditions and connectivity due to exploitation for household products and conversion to other land uses. Wetlands can remove between 20 and 80 percent of nitrogen by denitrification and uptake. With phosphorus, the slower flow rate of water in a wetland allows soil particles to drop out of suspension; but it also releases phosphorus from its less available forms into its bio-available form. If there is vegetation or algae to take this up and remove it from the system, there may be a reduction in phosphorus. If not, the wetland may become a source of phosphorus.

For agriculturists and ecologists, the conversion of wetlands for agriculture has elicited considerable controversy: agronomists regard the wetlands as the potential area for crop production whereas ecologists are more interested in conserving the ecology and biodiversity of wetlands. Therefore, some attempts exist to prevent further conversion of wetlands and to restore areas lost through reclamation or other human interventions.

Conversion of wetlands for agriculture may lead to negative effects such as:

- *Change of the habitat conditions* within the area thus adversely affecting plant and animal life (flora and fauna).
- *Land subsidence due to oxidation*, particularly if an area with peat soils is drained, making the area more prone to inundation as a result of water seeping in from adjacent areas.
- *Salinization* of the soil due to the lowered water table that induces saline seepage outside the area making the reclaimed area unsuitable for crop production.
- *Acidification* of soils that contain pyrites, which oxidize on being brought into contact with air, thereby triggering the formation of sulphuric acid that makes the soil pH condition unsuitable for either crop or animal life, thus affecting the quality of the surrounding water.
- *Leaching and free movement of nutrients*, pesticides and other elements, which increase through the loss of the filtering capacity of the swamps, thereby allowing the nutrients to find their way into water systems causing eutrophication and affecting the quality of water in such systems.

Drainage of wetlands for agriculture is often accompanied by the development of an irrigation system to provide water for the production of agricultural crops. Therefore, most of the drained areas in Kenya are major irrigation schemes that suffer recurring inundation problems.

One of the major problems affecting the physical performance of most irrigation systems is the clogging up of the irrigation canals, particularly if the water flowing into the system is loaded with sediment, thereby reducing its flow. The removal of sediment from the water delivery channels may raise the level of the fields due to the continued sediment deposition on the land. Cultivation of steep slopes could also increase sediment delivery into irrigation channels, particularly in instances where soil conservation measures are not practiced. Although channels and other irrigation structures may approach their design dimensions after sediment removal, they cannot deliver water to the fields as the field levels keep rising due to sediment deposition.

While the effects of wetland reclamation on drainage for agricultural purposes may be simple to quantify, it is more difficult to predict the overall environmental impacts. Studies have shown that in the Lake Victoria basin the degradation of wetlands has affected their filtering capacity (LBDA 1992). The challenge for wetland utilization is to increase agricultural land in such a way that ecological functions are maintained. The first step is to identify how upland management and wetland reclamation for development impact on the performance of irrigation schemes and on the water quality in rivers and lakes. Figure 1 illustrates some of the linkages.

Figure 1. Effects of nutrient and sediment flow on water quality and irrigation performance.

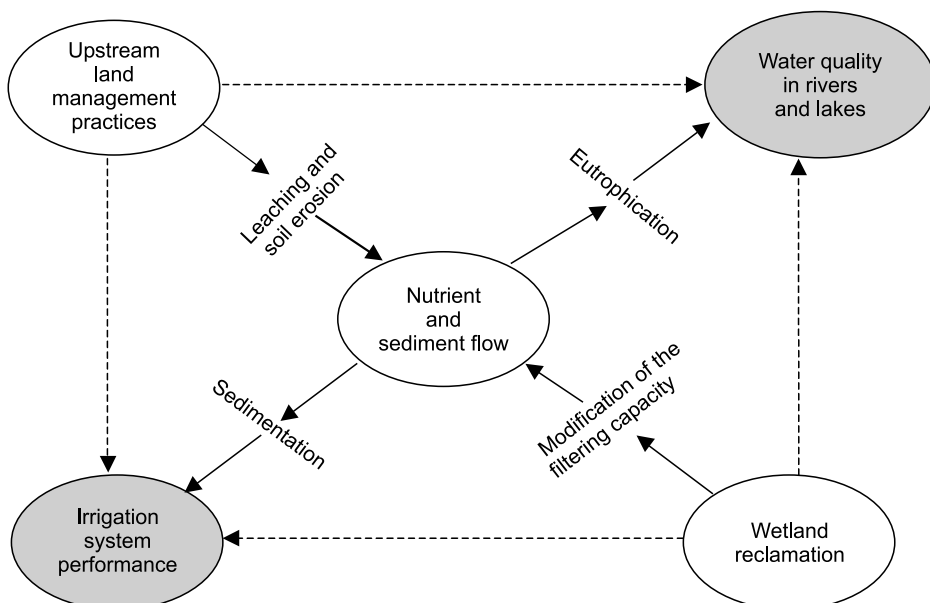

Therefore, the combined effect of poor upland management and wetland degradation permits free movement of sediment and nutrients through the water systems (canals, drains, rivers and streams) into both the irrigation schemes and the lake. The effects of all these interactions may be either sediment accumulation in the irrigation systems and/or nutrient accumulation in the water systems (eutrophication).

## Objectives of the Paper

Recently, the environment of Lake Victoria has attracted the attention of policy makers following its colonization by the water hyacinth (*Eichhornia crasipes*), which blocked water transport and fishing activities. The predominantly fishing community living around the lake was the most affected because the people of this community can no longer go out to fish and the quality of fish has become unfit for either export or local consumption.

Colonization of the lake by the water hyacinth is largely attributed to:

- increased levels of nutrients (particularly of phosphorus and nitrogen) that enter the lake from urban, agricultural and industrial sources, and
- sediment deposits originating from soil erosion due to poor upland management practices.

It has been argued that poor practices of land-use management (on both irrigated and nonirrigated lands) and the free flow of nutrients and sediment have a negative impact on the eutrophication of Lake Victoria. It is also postulated that the irrigation schemes developed within the area have also been affected by the sediment problem and have damaged the wetland's natural filter function. Against this background, therefore, the paper sets out to assess:

- how the land management practices in the Nyando river basin have contributed to the sediment load into the lake
- how the sediment load in the Nyando river and all the other rivers within the basin has affected the performance of the irrigation schemes developed within the river basin
- the level of usage of fertilizers and other chemicals and how this has contributed to the nutrient flow into the lake
- whether the conversion of wetlands into irrigation schemes has a negative impact on the quality of water in the lake and the sustainability of the irrigation schemes

## Lake Victoria and Its Environment

The Lake Victoria basin supports an estimated population of 27 million people, who produce an annual gross economic product of around US\$3–4 billion (SIDA 1999). With the exception of Kampala, the lake catchment economy is principally an agricultural one, with a number of

cash crops, fisheries and subsistence agriculture. The quality of the physical environment is crucial in maintaining and increasing the living standards of the growing population. It is estimated that a 5-percent reduction in the productivity of the region would lead to a loss of \$150 million annually. The lake basin is also used as a major source of food, energy, drinking and irrigation water, shelter, transport, and as a repository of human, agricultural and industrial waste. The Lake Victoria Environmental Management Program (LVEMP), which is a basin-wide project funded by the World Bank and the European Union since 1995, recognizes the fundamental importance of wetlands in relation to the lake's ecology, and is responsible for implementing policy for the sustainable development of wetlands. This policy includes due regard to their economic value, ecological importance and buffering value to the lake. In their recommendations, the consultants to LVEMP (Bullock et al. 1995) highlighted the importance of monitoring the buffering capacity of the lake-basin wetlands and integrating the socioeconomic considerations of wetlands.

Lake Victoria, surrounded by the three east African countries (Kenya, Uganda and Tanzania) is the world's second largest freshwater lake in the world with a surface area of 68,000 km<sup>2</sup> and an adjoining catchment area (comprising 12 major river basins) totaling 155,000 km<sup>2</sup>. One of these includes the Nyando river basin (figure 2), which is the focus of this review. Three other smaller rivers and tributaries of the Nyando river (Asawo, Awach-Kano and Nyaidho rivers) also contribute to the hydrology of the basin. The Nyando river basin has an area of 3,517 km<sup>2</sup> with the river and its tributaries originating from the western slope of the Mau escarpment and the Nandi hills. These are the two main mountain ranges lying between the Rift valley on the east and Lake Victoria on the west.

The area around the lake and within the river basin is characterized predominantly by poorly drained, fine textured, deep and fertile black cotton soils. The condition of the soils together with the multitude of rivulets and low-lying lands that characterize the area brings about water stagnation. Therefore, flooding is a common occurrence, and the area is known to suffer from periodic inundation, particularly after heavy rains in the adjacent escarpments and hills. Despite this shortcoming, the area is considered to have a very a high potential for irrigated agriculture, as irrigation water is abundant. For instance, it is possible to undertake irrigation by:

- pumping water from Lake Victoria
- gravity abstraction of water from the rivers, e.g., from the Nyando river and its tributaries
- using drain water from other irrigation and drainage schemes
- using pond water and water emerging from adjacent swamps

The ecosystem around the Lake Victoria basin has undergone substantial change during the last three decades due to two major human interventions in the basin. The first was the introduction of the Nile perch, which altered the food web structure. The second was the increased nutrient flows from the surrounding catchments into the lake. Although the most urgent problems in Lake Victoria are the water hyacinth, fishery and water quality, the lake is not the *source* of the problem. The root causes of eutrophication stem from continuing land degradation, resulting from deforestation, settlement, farming and accelerated soil erosion.



Figure 2. Map of Lake Victoria basin showing the location of the Nyando river basin.

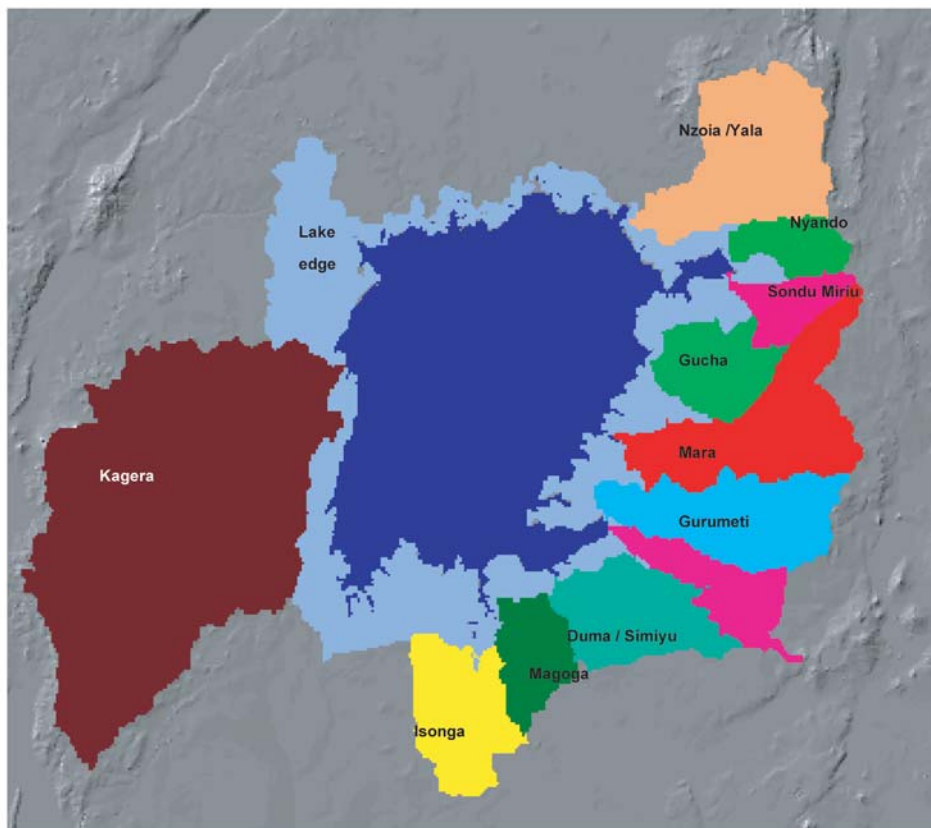

Sediment and nutrient loads on the lake are high and will further accelerate the process of eutrophication. Urban runoff is also an important component of pollution and will worsen the situation in the next few years. Industrial discharges and sewerage will exacerbate the problem, especially when considering the number of agro-industries in the Nyando river basin.

Although there is a wide consensus that nutrient levels in the lake have increased in recent decades, we do not have reliable information on the major sources and sinks of nutrients. Nutrients enter the lake from different sources (agricultural, atmospheric, urban and industrial) but there is some controversy about the relative importance of these different sources. Most methods are flawed or inadequate either because they were based on values extrapolated from North America (Bullock et al. 1995), small catchments in Tanzania (Scheren 1995) or on minor streams during a single year in Uganda (Lindenschmidt et al. 1998) (table 1). The three major riparian countries have very different agro-ecosystems, topography and discharge into the lake. Such extrapolations are therefore grossly unreliable for the whole basin, but the latter two might reflect differences in land use between the two countries. Nevertheless, these rough estimates indicate that the contribution from agricultural lands accounts for about half the

nutrient loads into the lake. Of the total water input into the lake, 85 percent comes as direct rainfall into the lake while the remainder comes from 12 major rivers. There is an urgent need to have more reliable data on the relative importance of each source, especially from the major rivers such as the Kagera on the west. A recent analysis, using topography and satellite images, of these major river basins indicates that the Nyando and Kagera river basins stand out in terms of sediment transport capacity and average slope (Walsh, personal communication, 2001, ICRAF).

*Table 1. Rough estimates of nutrient contributions (%) from various sources to Lake Victoria.*

	Agricultural	Urban	Atmospheric
1. Bullock et al. 1995	50	30	20
2. Scheren 1995	25	na	75
3. Lindenschmidt et al. 1998	57	6	37

na=Data not available.

Ongoing studies of land management practices in the Lake Victoria basin (ICRAF 2000) reveal serious land degradation on the fragile slopes and extensive gully formation in the Nyando river basin. While this evidence supports the fact that the sediment load of the Nyando river has increased over the last 15 years, the source of the sediment remains unclear as it varies greatly in place and time. However, the general consensus is that the origin of sediment is the uplands of the watercourses within the Nyando river basin.

It is widely believed that the large changes in hydrology and sedimentation of the lake basin are due to conversion of forests into agricultural lands. There is considerable evidence, especially from Kenya, of the strong relationship between land use, runoff and sedimentation from drainage basins. For example, sediment yield from undisturbed forest catchments loses sediment at a rate of 20 to 30 t km<sup>-2</sup> yr<sup>-1</sup>, while that from agricultural basins loses between 10 and several thousands t km<sup>-2</sup> yr<sup>-1</sup>, depending on the topography, runoff, and the proportion of the basin that is cultivated. Average sediment yield from agricultural regions was only 90 t km<sup>-2</sup> yr<sup>-1</sup>, with a range of 1,000 to 5,000 t km<sup>-2</sup> yr<sup>-1</sup> from the steepest and wettest slopes. Rangelands have similar variability, but sediment yields are generally higher. In the Nyando district, the area under agricultural lands has increased from 38 to 63 percent during the last 40 years (Hai et al. 2000) and, therefore, the adoption of soil conservation measures on cultivated land alone could have a major impact on sedimentation into the lake. In addition, the dense network of roads and footpaths, which constitutes about 1 percent of the basin area, has a low infiltration capacity and might contribute between 25 and 50 percent of the sediment yield of the basin.

Current monitoring by ICRAF and its partners of the water flow and quality of streams and rivers should establish the relationships between land use and nutrient loads. This information should allow the sediment load on riparian vegetation to be established. Knowledge of the buffering capacity of the wetlands and riparian strips will provide estimates of the ultimate loading on the lake. Combined with data from point-source pollution, management decisions

can be formulated that will determine the future development of the lake catchment and the environmental impact of converting wetlands into agricultural use.

The impact of human activities on the land and lake may be easily overshadowed by the huge natural fluctuations in climate and sedimentation, which are features of other lakes in the region. For example, the lake levels rose by 2.5 m following successive doubling of rainfall from 1961 and 1962 (Sene and Plinton 1994) and the levels have remained relatively high ever since. This long residence time (about 20 years) suggests that the impact of interventions on the eutrophication problem might take years to have a measurable effect. A recent analysis of the level of the lake using fossil diatoms as proxy records of rainfall over the last thousand years suggests even greater natural fluctuations in climate and sedimentation in the east African lakes (Verchuren et al. 2000). For the near future, the impact of El Niño rains on sedimentation rates in the basin should be assessed to establish the relative importance of such events compared to current land use change. Scientists are currently comparing the long-term trends in hydrology and sedimentation due to long-term changes in rainfall versus changes in land use.

In a review of more than 60 studies of sediment yields in Southeast Asia, Bruijnzeel (2000) concluded that the time scale for the downstream benefit from upland rehabilitation depends on the size of the river basins and sources of nutrients: the number of sediment storage opportunities also generally increases with catchment size. For large river basins, there may be so much sediment stored in the drainage basin itself that it effectively forms a long-term supply, even if all human-induced sediment inputs in the headwater were eliminated. Results from major land rehabilitations in China suggest that a reduction in sediment yield of up to 30 percent may be expected after 20 years for very large catchments (100,000 km<sup>2</sup>) (Bruijnzeel 2000).

Experience in the Baltic Sea illustrates the inertia of the terrestrial and aquatic systems that control the exports of nutrients from the land to the seas (Stalnacke 1996). Late in the 1980s, a goal of a 50-percent reduction of the nitrogen and phosphorus export to the North Sea and the Baltic Sea was adopted by HELCOM (Helsinki Commission) and action programs were initiated to achieve this goal by 1995. Results so far suggest that the reduction actually achieved was much smaller than anticipated, and the export of nitrogen has been particularly difficult to reduce despite major changes in land-based activities. In Sweden, massive reduction in point emissions of phosphorus by 200 t yr<sup>-1</sup> to less than 10 percent in the mid-1970s failed to reduce the riverine load even after 20 years! This evidence suggests that the present load is due to diffuse emissions to water or possibly internal loading from the riverbed. In Eastern Europe, the response of water quality to lowered nitrogen is even slower because of large amounts of organic nitrogen that have accumulated in the soil during periods of higher application rates, and that have resulted in the accumulation of nitrate in groundwater aquifers with a long residence time. In the Lake Victoria basin, fertilizer input is negligible compared to that in Europe and, therefore, the response to upstream land rehabilitation is expected to provide an earlier benefit to water quality in the lake. There is little reliable information on the time lag between land rehabilitation and any subsequent reductions in streamflow and sediment transport at increasingly great distances downstream.

## **Irrigation and Drainage Development in the Nyando River Basin**

When compared to the other areas around the Lake Victoria basin, the Nyando river basin has experienced the highest level of development in irrigation and drainage schemes. The last 20 years have witnessed a high rate of conversion of the Nyando basin wetlands into irrigated agricultural land, reaching an area of over 6,500 hectares. In the mid-1960s, the National Irrigation Board (NIB) reclaimed over 1,700 hectares to start the two pilot irrigation schemes (Ahero and West Kano irrigation schemes). The “success” of these two projects prompted the emergence of more schemes in the whole river basin. From the mid-1980s, over 4,000 hectares of government-assisted schemes have been developed with the support of the Provincial Irrigation Unit (PIU) of the Ministry of Agriculture, Livestock Development and Marketing. Several schemes (some as small as 3 ha) have also been constructed by the local community through their own initiatives and with little or no external support. The Lake Basin Development Authority (LBDA) has also earmarked a number of schemes for development following the feasibility study carried out in 1992 by the Japan International Cooperation Agency (JICA)—an exercise that may put more area under irrigation if the recommendations are implemented. Except for two schemes that were developed for vegetable production, it should be mentioned that all schemes in this river basin are meant predominantly for irrigation of rice fields.

Despite the above record of irrigation development, a sizeable portion of the reclaimed area is, however, rapidly reverting to swamps due to a multitude of reasons, the most prominent being sedimentation.

## **Flood Control and Wetland Reclamation**

As already mentioned, the Nyando river basin and, particularly, the lower reaches of the river basin are prone to flooding. In addition to the poorly drained cotton soils, flooding is mainly the result of the many rivers and rivulets that traverse the area—most of which frequently overtop their banks as they flow on relatively flat topographies. The high rainfall intensity, characteristic of the Lake Victoria region is yet another factor, though of minor consequence. The stagnation of water and flooding have, to a large extent, resulted in the growth of swamps at several locations around the lake, with the Nyando swamp being the largest, covering an area of over 10,000 hectares (LBDA 1992). Therefore, this area has developed into a prominent wetland, dominated by papyrus and bulrush vegetation.

Traditionally, the communities around the flood-affected area have existed by adopting various ways to overcome flooding. These include raising banks around their houses and lands, building houses on higher grounds or raised floors and evacuation during flooding to higher grounds. The government, through the Ministry of Water Development has made attempts to provide flood-protection measures through the construction of dykes, particularly along the Nyando river but this has been ineffective because the dykes do not cover the whole course of the river. Because of the frequency of the floods the reclamation of the wetlands has been considered one of the most effective ways of management. Most of the flood-control interventions generally stem from the reclamation of wetlands and the development of irrigation and drainage schemes.

Construction of canals through the wetlands, which act as either irrigation or drainage channels, is common. During the rainy season, when the capacity of most rivers causes overtopping of the banks, the channels convey the excess water away from the farmlands and homesteads into the lake. These channels are also used to convey water from the rivers or swamps into the irrigated lands during the dry season. Consequently, less and less water stagnates on the land, resulting in the drying out of the wetlands. A large section of the wetlands in the Nyando river basin has therefore been reclaimed through such interventions. In 1986, the area under wetlands was 10,000 hectares but 60 percent had since been converted to agricultural use.

## Sustainability of Irrigation Schemes

The following sections have identified two very related activities, i.e., wetland degradation and irrigation development, particularly at the lower reaches of the Nyando river basin. This development has persisted despite the inherent problems due to the high sediment load in most rivers draining into the area (and particularly the Nyando river). Therefore, it is crucial to establish how sedimentation has influenced the performance of the irrigation and drainage schemes because of the reduced buffering effect of the wetlands.

Several community-managed irrigation schemes were visited and field observations made in addition to holding discussions with different stakeholders. Three interesting cases are described below to illustrate the problems and challenges ahead. The three schemes indicated in figure 3 are:

- the Gem-Rae irrigation scheme,
- the southwest Kano irrigation scheme, and
- the Kore irrigation scheme

Figure 3. Irrigation schemes.

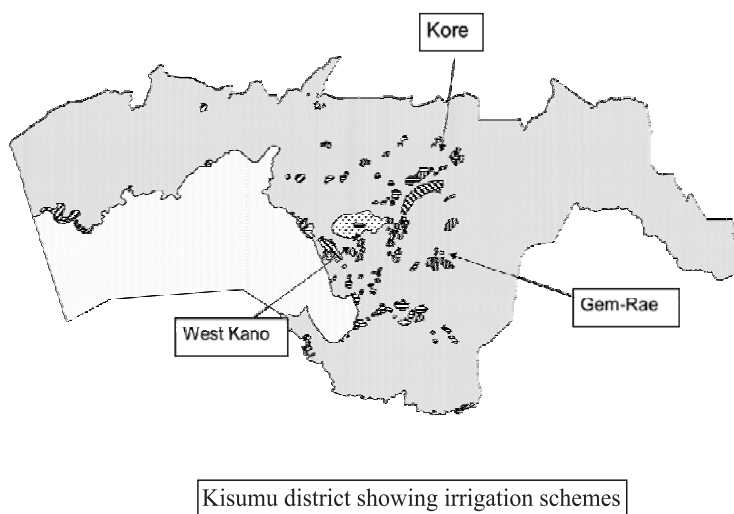

### ***Case 1. Gem-Rae Irrigation Scheme***

Developed in 1985 under the EEC-funded Smallholder Rice Project (SRP), Gem-Rae is one of the four cluster schemes in the Awach-Kano delta scheme designed to irrigate 350 hectares of rice. This scheme, like the other cluster schemes (i.e., Oyani-Nyachoda, Alara and Kopudo), shares the same source of water as from the Awach-Kano river.

The Awach-Kano river originates from within the Nyando basin and carries an appreciable amount of sediment, mainly sand and pebbles. The round-shaped pebbles indicate that the sediment has been transported as bed-load over a long distance. Due to this load, the intake (comprising a 6-m long concrete weir structure) started clogging up at the onset of the scheme. In the initial years, because of the frequency of sediment deposition, irrigation was undertaken only once every 2 years after removal of the sediment. However, after 4 years, sediment deposition at the intake as well as the main canal became so frequent that its removal had to be done at the start of every planting season (commencing July, every year). From 1992, the amount of sediment accumulation accelerated (suggesting that the erosive effect upstream of the river was also increasing) to the point that it had to be removed as often as three or four times during the entire 4-month growing season. From 1995, the removal of sediment was as frequent as twice a week.

The high rainfall patterns experienced in Kenya in 1997 due to the El Niño phenomenon sounded the death knell for the scheme. During this period, clogging of the intake became a weekly event and farmers were clearing sediment daily at the expense of farming. Maintenance records from the scheme indicate that as much as 200 m<sup>3</sup> of sediment was being removed weekly during this period from the intake as well as a section of the main canal.

From its inception until 1995, the Ministry of Agriculture financed the farmers to undertake maintenance work (mainly removal of sediment). Though sedimentation was controlled after the withdrawal of the financial support and the El Niño rains, the farmers could no longer cope with the situation.

Since 1997, sediment clearing stopped and the intake and part of the main canal have been completely clogged up. No water is therefore received within the scheme and the canals, and other irrigation structures (division boxes, offtake structures, etc.) have become nonoperational and are either clogged up with earth or overgrown with vegetation. Formerly well-demarcated rice fields have been overgrown with reeds and the once popular irrigation scheme has now been abandoned.

Driven by the hunger now prevalent in the area, several farmers are attempting to clear a part of the new swamp in a bid to produce some rice using residual water in the swamp. The yields are less than 0.5 t ha<sup>-1</sup>, compared to 3.5 t ha<sup>-1</sup> obtained previously. Less than 30 hectares are currently under this type of rice production and the *Quelea* birds that now inhabit the swamp consume most of the crop before it is harvested.

It can be concluded that the Gem-Rae irrigation scheme has been virtually abandoned because of the high sedimentation problems experienced. Another reason is the weak management structure. However, the principal reason seems to be sedimentation originating from the uplands. Rice production is one of the few livelihood alternatives in the area and, thus, farmers remain interested in reviving the irrigation scheme although the cost of rehabilitation is beyond their resources.

## *Case 2. Southwest Kano Irrigation Scheme*

The southwest Kano irrigation scheme forms the single largest farmer-managed irrigation scheme in the region. Developed by the PIU, it became operational in 1993 and was planned to cover a total area of 530 hectares. However, due to the enlargement of individual cluster schemes the total area was 825 hectares. The Nyando river is the major source of water to the scheme though additional water is received from the Nyatini drain (drain water from Nyatini irrigation scheme, a scheme developed by farmers and located right upstream of the southwest Kano scheme).

Soon after the scheme started it became evident that the southwest Kano scheme experiences a high level of sediment deposition. The sedimentation problem necessitated the formation of the Smallholder Irrigation Support Organisation (SISO), an organization established in 1993 with support from the Ministry of Agriculture to manage the project. On completion of the project, the major infrastructure was handed over to the organization with responsibilities to:

- operate and maintain the major irrigation infrastructure,
- ensure equitable supply of water through the major infrastructure to the different cluster schemes and farmers, and
- charge all farmers (through their cluster schemes), receiving water from the irrigation infrastructure, a maintenance fee to meet the O&M costs.

An O&M agreement was signed between the SISO and the farmers in different cluster schemes. Under this agreement, the farmers were solely responsible for the O&M of secondary works, in addition to remitting the “maintenance fee” to SISO for the O&M of the major infrastructure. On the other hand, the SISO was supposed to use these funds to meet the O&M costs of the schemes (including the removal of silt from the main system) as well as meeting its own overhead costs.

Despite the existence of this maintenance arrangement no serious maintenance work (particularly the desilting of the main canal) has been undertaken, because the SISO has never been able to raise enough money to meet the maintenance cost of the main canal, which is 3.5-km long. Due to the ever-increasing sediment deposition in the main canal, its capacity and the discharge that goes through it have been declining over the years, and consequently the area actually under production keeps changing (table 2).

*Table 2. Performance of the southwestern Kano irrigation scheme.*

Season	1995/1996	1996/1997	1997/1998	1998/1999
No. of schemes under production	19	16	-	19
Total area cropped (ha)	176	544	-	545
Average yield (tons/ha)	4.7	4.3	-	5
Maintenance fees collected (KSh)	336,505	408,059	-	318,454
Default in maintenance fee payment (%)	43	20	-	85

*Source:* Manager, SISO/PIU, Nyanza.

For instance, during the 1995/96 season, only 176 hectares (33% of the total area) were irrigated because only part of the main canal was cleaned. Very few cluster schemes actually paid the maintenance fee. Farmers in others schemes felt that despite making their payments previously, the amount of water delivered through the system did not improve as expected and therefore they defaulted payment. The intervention of the PIU in the following year, by attaching one of their staff as the manager to assist in collecting the maintenance fees, resulted in a marked improvement in the number of cluster schemes that paid up that season. A bigger section of the main canal was therefore desilted, albeit using manual labor, and more area was therefore irrigated during the 1996/97 season.

However, the 1997/98 season was a complete failure as no irrigation water was delivered to the schemes. The season came during the time the country was experiencing the El Niño rains, which dramatically increased the level of sediment deposited at the intake and along the main canal. The high sediment levels discouraged the farmers from paying maintenance fees and, therefore, no irrigation took place because no maintenance work was done.

The cost of mechanically dredging the entire main canal is estimated at KSh 700,000 (a cost that has been way above SISO's seasonal income). The only maintenance work so far undertaken has been manual removal of vegetation, which leaves most of the silt in the canals.

The area irrigated and the yield from the southwest Kano irrigation scheme depend on how effective the sediment is removed to give the main canal enough capacity to deliver the required discharge. However, this depends on the level of payment of the maintenance fees, which can only be improved if the maintenance is adequate enough to deliver the required amount of water. Therefore, the future of the scheme depends on a vicious circle that can only be broken by good management of the sediment in the Nyando river basin.

### ***Case 3. Kore Irrigation Scheme***

The Kore irrigation scheme was started in 1991 and covered an area of 300 hectares. It is located on the upper side of the NIB-managed Ahero pilot scheme and was developed through the farmers' own initiative. It sources its water from a swamp fed by the Ombeyi river. No major irrigation structures were constructed because the water was derived from a swamp. The main work undertaken included the construction of 10 concrete offtaking structures with spindle gates to control the flow of water into various sections of the scheme, and the excavation of water delivery and distribution canals. A cutoff drain-cum-delivery canal, around a swamp adjacent to the scheme, was constructed to convey water into the different distribution canals through the spindle gates.

Unlike most other schemes in the area (particularly those receiving water from the Nyando river), Kore is one of the schemes that is least affected by the sediment problem. Most of the sediment in the Ombeyi river is trapped as the water filters through the swamp and the amount of sediment reaching the scheme is quite small. In consequence, little maintenance work (particularly earth removal) is necessary, except for the uprooting of vegetation. However, this is done during the annual land preparation and the farmers consider this as a part of the routine land-preparation activity.

As far as rice production is concerned, there was no delay in starting the season because the irrigation system is able to deliver water punctually and rice yields have been relatively high (averaging 5.5 tonnes ha<sup>-1</sup>) as compared to other farmer-managed schemes whose average yields are relatively low.



In conclusion it has to be stated that the scheme's sustainability seems to be protected naturally by the filtering role of the wetlands unlike other schemes where the sedimentation problem is acute.

## **Impacts of Sedimentation on the Sustainability of Irrigation Schemes**

The three cases illustrated above highlight the impact of sedimentation problems on irrigation schemes and their potential solutions. In the Gem-Rae case, the scheme was abandoned barely 12 years after its inception. Although the southwest Kano irrigation scheme is still operational, the long-term future is bleak unless the high sediment load in the Nyando river is controlled. The Kore case provides a small, but promising, example of the benefit of a well-designed irrigation scheme, which utilizes the natural filtering capacity of the wetlands.

It can be said that, in general, the sediment problem has negatively affected irrigation schemes in the following three ways:

### ***Infrastructural System***

In the Gem-Rae irrigation scheme, the heavy sediment load in the river blocked the intake structure rendering it ineffective. It is possible that the poor siting of the intake channel contributed to the siltation problem. In the case of the southwest Kano scheme, the continued deposition of sediment in the main canal has changed the canal dimensions to the point where the flow through them is less than the designed flow. The performance of the irrigation structures is dependent on the attainment of the correct flow levels and the reduction particularly affects the division structures. Little or no water is being delivered to the various tertiary units and fields due to this problem. Not surprisingly, the farmers have resorted to damaging the weir sills of the division boxes or constructing new canals that bypass such structures.

In summary, it has to be stated that increased sedimentation arising from poor upland practices has a major impact on the viability of many irrigation schemes.

### ***System O&M***

Effective management of community investments like irrigation systems requires institutional arrangements and incentives to encourage the participation of all users in the day-to-day operational and regular maintenance work. Such arrangements are important if the water, which is generally scarce in most irrigation systems, is to be shared equitably to meet the needs of users. It is crucial to have a management arrangement that encourages all users to participate actively in the O&M of the irrigation structures. Studies (Oregó 2000) have established that inequity in water distribution is a major disincentive to farmer participation and contribution in maintenance activities. The sediment problem does not promote equity or ensure adequacy in water delivery and, hence, the participation cannot be achieved by all.

### ***Project Sustainability***

It is not surprising that the performance of most irrigation schemes abstracting water directly from the sediment-laden water sources is declining because the quantity delivered falls below the designed discharges.

The high rate of sedimentation from the Awach-Kano river dramatically increases the labor requirement and the cost of maintenance of the irrigation infrastructure in the case of the Gem-Rae scheme. Since there is little improvement in water delivery after the removal of sediment and vegetation, farmers have been discouraged from further participation in maintenance work. Little or no money is collected to meet the maintenance costs due to the increased labor requirement.

## **Effects on Water Quality of Lake Victoria**

As indicated in table 1, the contribution from agricultural lands accounts for about half the nutrient loads into Lake Victoria. Generally, agricultural development (and particularly irrigated agriculture) may bring about an increase in water pollution due to increased land use accompanied by high application of fertilizers and the use of other chemicals. In addition, the water flow regime of the rivers can be reduced due to greater water abstraction, which may consequently increase the concentration of nutrients in water that enters the lake.

The growing number of sugar and other agro-based industries within the river basin and their consequent discharge into the Nyando river will undoubtedly increase their contribution to the pollution of the lake. While there are no recent detailed studies to establish how the quality of water in the lake has deteriorated due to agricultural activities, the few studies on water-quality assessment already undertaken indicate that there has been an increased pollution of the lake waters since 1985. A pollution assessment study undertaken by JICA (LBDA 1992) established that the water quality in the Nyando river was relatively poor as compared to all other rivers within the lake basin. Particularly, the level of suspended solids was quite high, as indicated by the highest sediment transport index of 0.3 for all the rivers within the lake basin (ICRAF 2000). Therefore, it is possible that the high sediment load carries along with it an equally high nutrient load, which greatly affects the water quality in the lake.

The “Winam Gulf Baseline Study” conducted from 1984 through 1985 provides comprehensive water quality data in the lake and particularly in the Winam Gulf. The “Secchi depths” (a scale for measuring the transparency of water) were found to be low in the gulf; about 0.3 to 0.4 at the eastern lakeshore as compared to 1.6 to 2.4 at the central part of the gulf. This low transparency value can be attributed mainly to suspended load and the algae blooms that were promoted by high levels of nutrients in the water. The total nitrogen (T-N) was found to range from 0.5 to 0.63 mg/l and the total phosphorus (T-P) from 0.02 to 0.04 mg/l. The high level of nitrogen could be a result of the use of animal manure as well as other nitrogen-based fertilizers. The actual source of the nutrients however needs to be investigated, even though fertilizer usage among smallholder farmers in the area (both in irrigated and nonirrigated fields) is reported to be low.

Analysis of satellite images taken around the lake between 1986 and 2000 revealed a sediment plume in the Winam Gulf (through which the Nyando river drains into Lake Victoria) on the eastern part of the lake (ICRAF 2000) while qualitative (verification work is underway), evidence indicates that the Nyando river is a major contributor to the sediment load in Lake Victoria.

There are no data on the buffering capacity of the wetlands around Lake Victoria. However, it is possible for the swamps to have a high buffering capacity and degradation of

the wetlands around the lake though the development of irrigation and drainage schemes contributes to the deterioration of the water quality because the buffering capacity is reduced. Additional studies are needed to quantify this hypothesis.

## **Intervention Strategies**

Many reports have argued for the need to conserve wetlands around the lake. Since the main livelihood in the communities along the Nyando river basin is farming, wetlands will continue to be converted into agricultural lands to meet food needs. Reducing the flow of nutrients by erosion from the impoverished rural landscapes and from untreated sewage from the growing population would not only improve the water quality and ecology of the lake but also benefit food security, health, income and productivity of the land. Although the amount of inorganic fertilizer application in irrigated areas is negligible to nonexistent, large amounts of soils are lost from the once-fertile lake basin. Therefore, interventions should simultaneously raise agricultural productivity and reduce erosion. In Kenya, considerable productivity and economic success have been achieved by the National Soil and Water Conservation Program (NSWCP) using the “catchment approach,” which is based on an area covering one or two villages rather than in the hydrological sense. With this approach, resources and soil conservation efforts are concentrated within a specific focal area for a limited time and the local communities are involved in the identification and implementation of interventions (Thompson and Pretty 1996). A recent study of the effectiveness of the catchment approach in terms of targeting areas of high erosion risk in the Nyando district by the NSWCP showed that less than 8 percent of the erosion-risk area is covered by the catchment approach (Hansen 2000). Thus, better targeting of interventions on the erosion hot spots is necessary to ensure a greater reduction in sedimentation from the Nyando river basin. Several opportunities exist to prevent the lateral flow of water, sediments and nutrients from the landscapes into the lake (Van Noordwijk et al. 2000).

### ***Controlling Surface Erosion: Filter Strips***

Recent studies in Sumatra, Indonesia show that simple land-based activities, using natural filter strips or vegetation are effective in reducing sediment transfer even on steep slopes (Utomo et al. 1999). Surface cover, condition of the land use system and farming activities (tillage, weeding, fertilizer application) have a great impact on sediment transfer, in addition to other soil-erosion factors such as slope and soil type. For example, retaining weed/grass strips or delaying weeding in coffee plantations can substantially reduce sediment movement. Furthermore, agroforestry systems, such as multistrata and mixing calliandra and coffee, also produced a very low sediment yield. A short filter cover is more effective in trapping the sediment than a very long one because runoff will have opportunity to accumulate in the longer slope and a rill will be created if there is concentrated flow.

### ***Gully Erosion***

Gully erosion is common in the Nyando river basin. Active gullying may be related to soil compaction by overgrazing or improper discharging of runoff from roads, trails and settlements. If gullies are not treated promptly, they may reach a stage when restoration becomes difficult

and expensive. The use of vegetation on actively eroding gullies is limited and additional mechanical measures, such as check dams, retaining walls and diversion ditches, are required.

### ***Riparian Zones for River Banks***

Numerous studies have shown that riparian zones play an important role in shaping stream ecosystems, influencing habitat complexity, biodiversity and in restoring eutrophic lakes (Haycock et al. 1997). Appropriate riparian management could reduce sediment load by 85 percent, phosphorus by 47 percent and nitrogen by 40 percent. Riparian areas can buffer streams from a variety of land-use impacts, especially in improving the infiltration of compacted grazing lands and storing sediments. However, riparian zones should not be regarded as inexhaustible sinks for high nutrient inputs, and it is vital to match nutrient inputs to sustainable rates of nutrient removal if long-term benefits of water quality are to be improved. Two considerations are central to the adoption of riparian zones: community ownership and ongoing maintenance, and developing profitable incentives because farmers do not rank them highly in terms of income generation.

### ***Afforestation***

There still remains much folklore and many myths about the role of land use and its relation to hydrology, especially in relation to deforestation and afforestation, which hinder rational decision making in land use (Calder 1997; Bruijnzeel 2000). When scrutinized, many of these myths are found to be either exaggerated or lacking in evidence. These include the roles of forests in increasing rainfall and runoff, regulating low flows, reducing floods, improving water quality and reducing erosion. Two points are worth mentioning in terms of the Lake Victoria basin. First, although reforestation and soil conservation measures are capable of reducing the enhanced peak flows and stormflows associated with soil degradation, there is no well-documented case where this has also produced a corresponding increase in low flows. This is possibly because storage opportunities of soil water have declined as a result of soil erosion during the post-clearing phase. Second, the most crucial factor in terms of soil erosion is to have a good plant cover to prevent surface erosion rather than tree cover, as mentioned earlier.

### ***Controlled Use of Fertilizers***

There is no documentary evidence to suggest an excessive use of inorganic fertilizers and chemicals in the Nyando river basin but a controlled use will have a positive effect on the contribution of agricultural activities towards pollution of the lake. Information from the field indicates that fertilizers provided to the tenant farmers in the NIB-managed schemes are not actually used within these schemes. Rather, most of the fertilizers are sold to smallholder farmers outside these schemes and their application methods, coupled with the water management systems used, may provide easy avenues for the fertilizers to find their way into watercourses.

### ***Wetland Conservation***

The case of the Kore irrigation scheme highlighted above showed that the sustainability of irrigation schemes developed in sediment-loaded river basins can be feasible if the irrigation water is filtered through swamps and not abstracted directly from the run of the river. It shows that it is possible to simultaneously undertake irrigation development and wetland management. However, this calls for very pragmatic policies and programs that can be easily implemented

to ensure sustainable development and conservation work, particularly involving the local communities.

Farmers within irrigation systems already appreciate the negative effects of sedimentation on their irrigation systems. The Kore case illustrates the enormous benefits to farmers that can be achieved by conserving some wetlands around their irrigation schemes. Therefore, each drainage activity for the development of an irrigation scheme should be accompanied by maintaining or recreating a wetland upstream of the irrigation scheme. This will ensure that sediment does not enter irrigation systems and that its movement into the lake is controlled.

The potential area that should be put under wetlands needs to be investigated. The study should determine the nutrient and sediment level that can be achieved through improved land management practices and controlled fertilizer use. The filtering capacity of the swamps around the lake basin also needs to be investigated.

## **Further Research**

This paper has attempted to raise issues of the impact of poor land-management practices and the degradation of wetlands on the sustainability of irrigation systems and the water quality in rivers and lakes. While the evidence highlighted here provides some arguments on the need to adopt a concerted approach in the management of the hydro-ecological system of the lake basin, further research work is still necessary if more specific and tangible intervention measures are to be recommended. The following research work is therefore recommended:

1. Although nutrient flow from agricultural lands is the major source to the lake there is still insufficient data for a reliable estimate of the mass balance of the nutrient loading into and out of the lake, especially from industrial and atmospheric sources. Therefore, actual point sources and the contribution of nutrient pollution from agricultural lands should be investigated and quantified.
2. It is beyond question that the wetlands have a filtering capacity against sediment and nutrients. The effectiveness of wetlands in sediment and nutrient filtering should be assessed.
3. There is an urgent need to establish a relationship between land use and nutrient loads, and the buffering capacity of the wetlands and riparian vegetation.
4. The sources of sediment (erosion hot spots) within the river basin and the lake basin as a whole must be identified and quantified as a means of identifying the most appropriate measures of erosion control. Although there are numerous opportunities to prevent the lateral flow of water, sediments and nutrients into the lake there is an urgent need to develop methods that increase the incentives attractive to smallholders to adopt them without loss of crop production.

## Literature Cited

- Bruijnzeel, L. A. 2000. Tropical forests and environmental services: Not seeing the soil for the trees. *Agriculture, Ecosystems & Environment* (in press).
- Bullock, A.; S. O. Keya; F. M. Muthuri; Baily-Watts; R. Williams; D. Waughray. 1995. Lake Victoria Environmental Management Program Task Force 2. Final report by regional consultants on Tasks 11, 16 and 17 (Water quality, land use and wetlands). UK: Wallingford. Centre for Ecology and Hydrology and Food and Agriculture Organization of the United Nations.
- Calder, I. R. 1998. Water-resource and land-use issues. SWIM Paper 3. Colombo. Sri Lanka: International Water Management Institute.
- Hai, M.; C. K. Ong; D. Mungai. 2000. *The impact of land use and rainfall on sedimentation and runoff in the Lake Victoria basin*. Poster presented at the UNESCO-IUFRO Symposium on "Forest, Water and People" in the Humid Tropics: Past, Present and Future Hydrological Research. Malaysia: University Kebangsaan, 30-4 August 2000.
- Hansen, T. S. 2000. *Evaluating the environmental impact of participatory soil and water conservation at the watershed level in Nyando watershed, western Kenya*. Poster presented at the UNESCO-IUFRO Symposium on "Forest, Water and People" in the Humid Tropics: Past, Present and Future Hydrological Research. Malaysia: University Kebangsaan, 30-4 August 2000.
- Haycock, N; T. Burt; K. Goulding; and G. Pinay. 1997. *Buffer zones: Their processes and potential in water protection*. UK: Quest Environmental.
- ICRAF (International Centre for Research in Agroforestry). 2000. *Improved land management in Lake Victoria basin: Linking land and lake and research and extension, catchment and lake basin*. First Report of Progress and Results, July 1999 to March 2000. Nairobi, Kenya.
- LBDA (Lake Basin Development Authority). 1992. Feasibility study on Kano plain irrigation project. Japan International Cooperation Agency. Nairobi, Kenya.
- Lindenschmidt, K. E.; Suhr M. Maguma; R. E. Hecky; and F. W. B. Bugenyi. 1998. Loading of solute and suspended solids from rural catchment areas flowing into Lake Victoria in Uganda. *Water Research* 32: 2776-2876.
- Maltby, E. 1986. *Water-logged wealth*. London: Earthscan Publication, 1950pp.
- Orego, F. O. 2000. Devolution in irrigation financing for improved system performance: A solution or an illusion. M.Sc. thesis. The Netherlands: Wageningen University. Duplicated.
- Ritzema, H.P., ed. 1994. *Drainage principles and applications*. ILRI Publication 16 (second edition). Wageningen, The Netherlands. International Institute for Land Reclamation and Improvement.
- Sene, K. J.; and D. T. Plinton. 1994. A review and update of the water balance of Lake Victoria in East Africa. *Hydrological Sciences Journal* 39-1.
- Scheren, P. A. G. M. 1995. *A systematic approach to lake water pollution assessment: Water pollution in Lake Victoria, East Africa*. Netherlands: Eindhoven University of Technology, 71pp.
- SIDA (Swedish International Development Agency). 1999. Strategy for Swedish support to sustainable development in the Lake Victoria region, Sweden. 20pp. Stockholm, Sweden.
- Stalnacke, P. 1996. Nutrient loads to the Baltic Sea. Ph.D. diss. Sweden: Linkoping University.
- Thompson, J. and J. N. Pretty. 1996. Sustainability indicators and soil conservation- A participatory impact study and self-evaluation of the catchment approach of the Ministry of Agriculture, Kenya. *Journal of Soil and Water Conservation*.
- Utomo, M.; R. A. B. Rosadi; and Maryanto, Nurarifaini, Setiyanto. 1999. *Watershed erosion analysis and simulation modelling of river channel erosion in Tulang Bawang river basin*. University of Lampung/ Bogor Agricultural Institute/ICRAF, 28pp. Bogor, Indonesia.

- Van Noordwijk, M.; J. Poulsen; and P. Ericksen. 2000. Filters, flows and fallacies: Methods for quantifying external effects of land use change. *Agriculture, Ecosystems & Environment* (in press).
- Verchuren, D.; K. Laird; and B. F. Cumming. 2000. Rainfall and drought in equatorial east Africa during the last 1,100 years. *Nature* 403: 410–414.

# Impact of Water Scarcity on Pastoral Systems: Experience from the 1995–97 Drought and the 1997–98 El Niño Rains in the Greater Horn of Africa

*Jean Ndikumana<sup>1</sup>*

## **Abstract**

A study was carried out by the ASARECA Animal Agriculture Research Network (A-AARNET) to identify the traditional coping mechanisms to crisis situations in pastoral areas of the Greater Horn of Africa through a survey on the effects and responses of pastoralists and livestock during the 1995–97 drought and the 1997–98 El Niño rains. Considering that water is one of the major factors affecting determinants.

## **Introduction**

A survey study of 664 households in southern Ethiopia, northern and southern Kenya, northern, northwestern (NW) and central Tanzania and central/southwestern (C/SW) Uganda on coping mechanisms of pastoralists and agro-pastoralists, was conducted during the 1995–97 drought and the 1997–98 El Niño rains (floods). The purpose of the study was to obtain baseline information about what pastoralists did to sustain themselves and their livestock during the crisis periods of drought and flood. The survey focused mainly on the assessment of the effects of the crises on livestock dynamics and household welfare, the coping mechanisms adopted by the pastoralists to mitigate the effects of the crises and their efficacy.

Considering that during crisis periods, trekking for water sources is one important facet of the pastoral strategy affecting the capacity of the pastoralists to produce from the rangeland (Dyson-Hudson 1991; Niamir-Fuller 1998), the impact of the drought and El Niño rains on water sources for human and livestock was one of the areas investigated.

## **Methodology and Target Zones**

Based on an analysis of the Cold Cloud Duration (CCD) and on the Normalized Difference Vegetation Index (NDVI), the investigation period was divided into the following five phases: a) pre-drought (January 1 to May 10, 1995), b) peak drought (May 11, 1995 to March 31, 1997), c) minor rains (April 1 to October 31, 1997), d) El Niño rains (November 1, 1997 to May 31, 1998), and e) La Niña dry period (June 1 to December 31, 1998).

A survey questionnaire was used that addressed the issue of types of water sources and distances trekked fetching for water inter alia during the climatic phases.

---

<sup>1</sup>A-AARNET Coordinator.



The area demarcated as the S. Ethiopia zone is semiarid to arid. The main pastoral groups are the Borana people who are pure pastoralists. Somali clans are also found in this zone. The pastoralists in this zone are greatly dependent on livestock for food security.

The zone surveyed in northern Kenya is semiarid to arid. The major pastoral groups are Samburu, Turkana, Borana and Somali who are pure pastoralists or practice transhumance, i.e., the practice of moving between seasonal bases, while carrying out some cultivation at the wet season base (Niamir-Fuller 1998). The two major pastoral groups in the southern Kenya zone are the Maasai who are pure pastoralists, and the Kamba who are agro-pastoralists.

The Maasai, Barbaig (pure pastoralists), Iraqw and Pare (agro-pastoralists) peoples occupy the northern Tanzania zone. The Maasai, who are pure pastoralists, and the Gogo, Irangi and Nyiramba agro-pastoralists are found in the central Tanzania zone. The northwestern Tanzania zone is dominated by the Sukuma and Nyamwezi, who are agro-pastoralists.

The two zones in Uganda are combined as they have many similarities. The pastoral groups include the Bahima in southwestern Uganda and the Banyankole and Baruli in central Uganda. These groups are constituted by agro-pastoralists, who raise crops, and semi-transhumant pastoralists who divide livestock into core and satellite herds.

## Major Results and Discussion

### *Impact of the Drought and El Niño Rains on Water Sources for Livestock*

*Figure 1. Livestock at a shallow river.*



Trekking for water of consumable quality for livestock is one of the key determinants of pastoral movement and migration (see figure 1, 156). A number of different livestock water sources were used across the zones: boreholes (established by the use of drilling equipment), hand-dug wells, dug streambeds (excavated dry or sluggish streambeds to encourage seepage of water), ponds, concrete tanks on the ground, concrete tanks above the ground and reservoirs/dams.

In the arid and semiarid areas, surface water is scarce and most of these water sources are recharged by rainfall (see figure 2, 158). Other water sources are dependent on underground reservoirs; their supply is unknown and is often affected by insufficient recharge. Therefore, water sources reflect the climatic situation, and thus the number and proximity of the water sources will change with drought conditions. The quality of water is also affected by climatic factors. Extended dry periods result in the drying up of water sources making the dwindling water supply unfit for livestock and human consumption. Flooding causes excessive runoff from adjacent areas, resulting in disease agents and other pollutants washing into water sources.

Annex figures 1–9 present the water sources used during the pre-drought, peak drought and El Niño phases in the different zones. Across zones, with the exception of south Ethiopia and north Tanzania, in the pre-drought phase, hand-dug wells were the most commonly used water sources. In south Ethiopia, ponds were the most important water sources while reservoirs and dams were the major water sources in north Tanzania. During the drought phase, hand-dug wells continued to be the most common water source across zones, with the exception of north Tanzania and C/SW Uganda where reservoirs and dams were more important. Pastoralists resorted to digging streambeds using boreholes, measures that indicated scarcity of water. The practice of excavating streambeds is resorted to when streams dry out. At some locations, boreholes carry a mandatory fee, and are thus avoided until other sources are exhausted.

During the El Niño phase, across zones, with the exception of C/SW Uganda, ponds were the dominantly used water sources. In C/SW Uganda, the most commonly used water source was dug wells.

The mean number of water sources for livestock used by pastoral households in the zones are provided in table 1. Two categories were identified in relation to environmental stress. They include those that were normally accessible to the households, which were designated as the primary water sources, and emergency water sources, which were those that the pastoralists had to seek out or were made accessible to them.

At some locations, because primary sources had dried out pastoralists had to utilize the emergency sources. At other locations, emergency sources were used to reduce the burden on the primary sources.

There were significantly less ( $P < .001$ ) water sources accessible to pastoralists during the drought compared to primary sources used during the pre-drought phase in all zones except north and south Kenya, and north Tanzania. Due to additional emergency water sources, north Kenya had significantly ( $P < .05$ ) more drought water sources than during the pre-drought phase. The difference was not significant for south Kenya and north Tanzania.

There was an increase in the number of water sources available for livestock with the onset of minor rains in all zones except in north Tanzania. A further increase was recorded during the El Niño phase, except in the pure pastoral areas of south Kenya and the agro-pastoral areas of north Tanzania. In all zones, emergency water sources were used during the El Niño phase; this could reflect contamination of primary sources.

*Table 1. Mean number of water sources for livestock during each climatic phase in the zones surveyed.*

Location	Pre-Drought 1995	Drought 1996	Minor Rains 1996–97	El Niño Rains 1997–98	La Niña Dry 1998
Southern Ethiopia PP	4	2 (1) <sup>a</sup>	5	6 (2)	2
Northern Kenya PP	3	3 (6)	4	5 (2)	2
Southern Kenya					
Agro-pastoral	1	1 (1)	2	3 (1)	1
Pure pastoral	2	1 (5)	2	2 (1)	2
Northern Tanzania					
Agro-pastoral	2	2 (2)	2	2 (1)	2
Pure pastoral	2	2 (2)	2	4 (2)	2
Central Tanzania AP	2	1 (1)	5	6 (2)	2
NW Tanzania AP	2	1 (1)	4	5 (2)	2
C/SW Uganda AP	2	1 (1)	3	6 (1)	2
Means: Agro-pastoral					
Pure pastoral	2	1 (1)	3	4 (1)	2
Pure pastoral					
	3	2 (4)	3	4 (2)	2

<sup>a</sup>Values in parentheses are emergency sources.

PP = Pure pastoral; AP = Agro-pastoral.

*Figure 2. A dry riverbed.*



During the La Niña dry phase, across zones, the number of water sources used by pastoral households were reduced to pre-drought levels with the exception of south Ethiopia and north Kenya, where fewer water sources were available. This latter observation could reflect the prediction, through NDVI analysis, of another drought for these two zones. In general, the agro and pure pastoral zones had access to a similar number of water sources, with slightly more availability for pure pastoral groups during the pre-drought and drought phases due to emergency sources. There were also more emergency livestock water sources in the pure pastoral zones during the drought phase.

### *Distances Trekked to Water Sources*

The number of water sources for livestock, however, belies true accessibility, i.e., accessibility of a water source must reflect both the presence of the resource and distance to the resource. The quality of a water source was also a key determinant of trekking distance. Poor quality/contaminated sources that had water unacceptable to livestock were abandoned in preference to better-quality sources located further away. Mean distances trekked by livestock to water sources during the period under investigation are indicated in table 2 and figures 3 and 4. Trekking long distances to watering points reduced effective grazing time available to livestock, and in some zones, the frequency of watering of livestock was also reduced to once every 3 to 4 days. Coppock (1994) observed that restricted watering is a strategy that allows livestock to cover greater radii in search of grazing sites, reduces herding and watering labor and increases the efficiency of water use.

*Table 2. Mean distances (km) trekked by livestock to watering points by zone/pastoral category.*

Location	Pre-Drought	Drought	Minor Rains	El Niño Rains	La Niña Dry
Southern Ethiopia PP	22.4	77.3 (81.3) <sup>a</sup>	2.4	1.3 (3.7)	3.6
Northern Kenya PP	4.7	8.5 (19.2)	2.3	1.3 (3.3)	3.6
Southern Kenya					
Agro-pastoral	3.9	4.2 (3.5)	2.1	1.6 (1.6)	3.0
Pure pastoral	3.4	9.3 (12.9)	3.1	1.5 (1.3)	2.2
Northern Tanzania					
Agro-pastoral	4.5	7.1 (7.1)	3.1	2.0 (1.5)	2.7
Pure pastoral	8.1	9.2 (5.4)	2.4	1.3 (1.1)	1.9
Central Tanzania AP	2.9	3.1 (4.1)	2.4	1.3 (3.7)	3.6
NW Tanzania AP	2.2	3.1 (2.9)	2.3	1.3 (3.3)	3.6
C/SW Uganda AP	1.4	4.7 (5.8)	2.3	1.2 (3.6)	3.9
<hr/>					
Means: Agro-pastoral	3	4.4 (4.7)	2	1.5 (2.7)	3.4
Pure pastoral	9.7	26.1 (29.7)	3	1.6 (2.4)	2.8
Overall	5.9	14.05 (15.8)	2.5	1.4 (2.6)	3.1

<sup>a</sup>Values in parenthesis are distances to emergency sources.  
PP = Pure pastoral; AP = Agro-pastoral.

The overall data indicate that during the pre-drought phase, all livestock trekked from 1 km to 8 km to water except in south Ethiopia where livestock trekked an average of over 22 km. During the drought, all zones had some emergency water sources. Livestock in south Ethiopia, north Kenya, and C/SW Uganda trekked significantly longer ( $P < .001$ ) distances while the distances to watering points in south Kenya agro-pastoral and north Tanzania agro-pastoral areas were significantly longer ( $P < .05$ ) compared to pre-drought distances. The difference was not significant for other zones.

The onset of the minor rains dramatically reduced distances to watering points for livestock to below those in the pre-drought period across the zones. Distances to both primary and emergency watering points were further reduced during the El Niño period; however, generally, the distances to emergency watering points were further than to primary watering points. This reflects the preference of the pastoralists to the emergency watering points due to contamination of the primary watering points. During the La Niña phase, distances to watering points increased compared to those in the El Niño phase; however, they were still lower than those in the pre-drought phase except in the agro-pastoral zones of central Tanzania, NW Tanzania and C/SW Uganda.

In general, the livestock in the pure pastoral zones traveled longer distances to watering points during all the phases, with the exception of the La Niña dry phase. The onset of the minor rains equalized the distances traveled by livestock in the agro-pastoral and pure pastoral zones. Livestock in south Ethiopia, in general, traveled much further distances to watering points than those in all the other zones.

Figure 3. Distances trekked to primary watering sources for livestock across climatic phases for all zones except south Ethiopia.

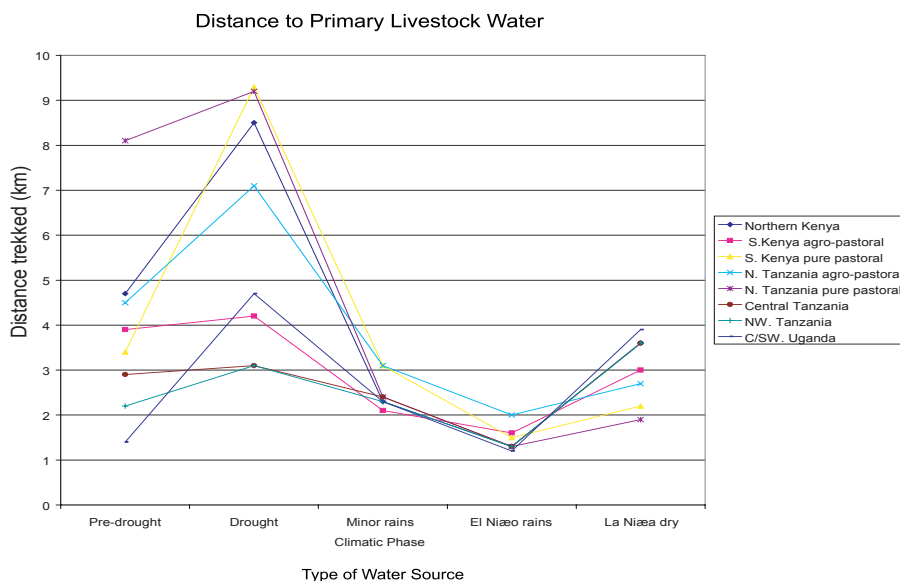
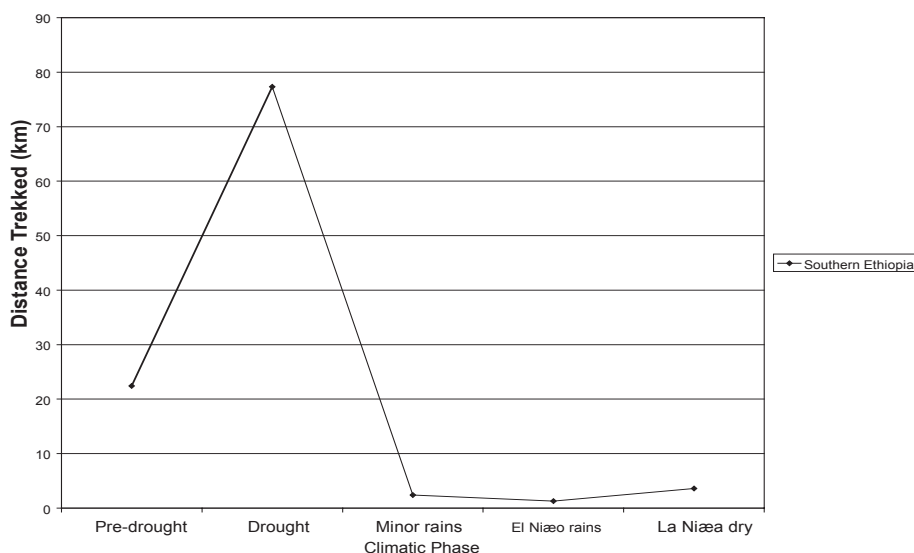

Figure 4. Distance trekked to primary livestock watering sources for livestock across climatic phase in south Ethiopia.



### *Sources of Water for Human Consumption*

In most cases across zones, human beings shared the same water resource as livestock. However, in some zones, special sources of water such as boreholes were constructed by government agencies and NGOs to supply water for human beings only. These sources of clean water had a mandatory fee, which was a deterrent to some of the pastoralists who opted to fetch water from free, though less-hygienic, sources. Table 3 presents the two water sources most commonly used by pastoralists for their consumption in each zone during the different phases.

Generally, across zones, hand-dug wells were the most commonly utilized source of water for human consumption, being cited as one of the two most commonly used sources for all zones except south Ethiopia and north Tanzania. From table 3 it is evident that pastoralists in south Ethiopia, central Tanzania, NW Tanzania, and central/south west Uganda were heavily reliant upon their main source of water (more than 40% of the respondents in these zones used the most common water source across climatic phases). The use of the most common source decreased with the onset of drought in south Ethiopia, central Tanzania, and central/southwest Uganda; it increased for north Kenya, where there was a greater reliance on wells and less on rivers/streams.

During the minor rains, all zones relied more on their most commonly used water source, however, going into the El Niño phase, pastoralists in north Kenya and central Tanzania relied less on wells which were generally their most commonly used source across phases. More pastoralists in north Kenya used rivers and streams, and those in central Tanzania used other sources. This may reflect the fact that wells may be further from households (in some centralized

*Table 3. Percentage of respondent households using the most commonly used water sources during various climatic phases (1995–1998) in the zones surveyed.*

Zone	Water Source	Pre-Drought	Drought	Minor Rains	El Niño Rains	La Niña Dry
<b>Southern Ethiopia</b>						
Pure pastoral	Pond	48	14	54	43	56
	River/stream	16	33	18	22	5
<b>Northern Kenya</b>						
Pure pastoral	Well	47	58	29	12	36
	River/stream	30	13	23	43	41
<b>Southern Kenya</b>						
Borehole	20	17	17	17	23	
Agro-pastoral	Well	27	27	10	10	20
Pure pastoral	River/stream	25	28	23	25	31
	Well	17	17	19	11	16
<b>Northern Tanzania</b>						
Agro-pastoral	River/stream	35	32	38	29	38
	Borehole	15	24	17	12	15
Pure pastoral	River/stream	28	26	31	25	25
	Pond	20	21	28	25	25
<b>Central Tanzania</b>						
Agro-pastoral	Well	47	38	43	24	40
	Borehole	28	36	29	22	24
<b>Northwestern Tanzania</b>						
Well	61	67	61	58	64	
Agro-pastoral	Borehole	13	15	12	10	12
<b>Central/Southwest Uganda</b>						
Well	62	33	59	64	64	
Agro-pastoral	Borehole	12	15	12	12	12

location) or may carry a mandatory fee charged to users. Usage of water sources during the La Niña phase was similar to that for the pre-drought phase.

A comparison of the pattern of usage of water sources for livestock and human consumption showed that there were similarities across the phases. Generally, with the exception of south Ethiopia, pastoralists relied on wells for both human and livestock water in the pre-drought and drought phases. There was a general shift toward usage of ponds, rivers and streams for livestock and domestic water with the onset of the minor rains, and the El Niño rains for all zones, except for central Tanzania, north Tanzania and C/SW Uganda, where wells were predominant sources of domestic water during the minor and El Niño rains.

## **Conclusions**

Mobility is an inherent strategy of pastoralists to optimize production from a heterogeneous landscape under precarious climatic conditions. The search for forage as well as for water for human and livestock consumption triggers mobility and migration, which were shown to be intensified by drought.

Distances trekked to livestock water sources tripled with the drought, from an average of 5.9 km pre-drought to 15.8 km on average across zones, with pure pastoralists trekking further distances than agro-pastoralists. Distances to grazing sites increased from an average of 5.5 km to 20.4 km across zones, with pure pastoralists again trekking further distances. Emergency water sources and grazing sites were used but they were not necessarily further away from the homestead compared to primary grazing. For example, in some areas, swamps/marshlands that were closer than the primary grazing sources were used in emergency times. Pastoralists avoided these areas as much as possible during other times because they were disease-infested areas. In general, distances trekked to water were further than to grazing sites. Distances to emergency water sources and grazing sites were furthest for the most arid zones of south Ethiopia and north Kenya.



Percentage of Respondents Utilizing the Different Kinds of Water Sources in the Various Study Zones

Figure 1. Percentage of respondents in south Ethiopia utilizing the different kinds of water sources.

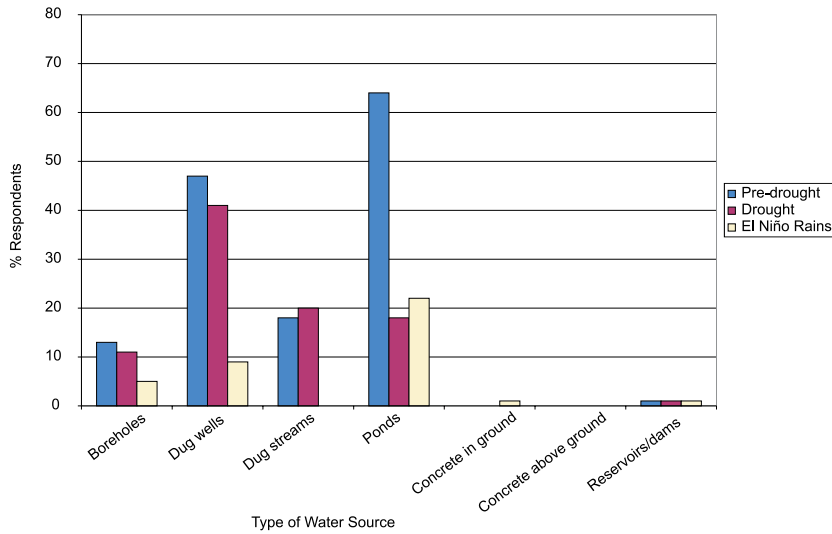

Figure 2. Percentage of respondents in northern Kenya utilizing the different kinds of water sources.

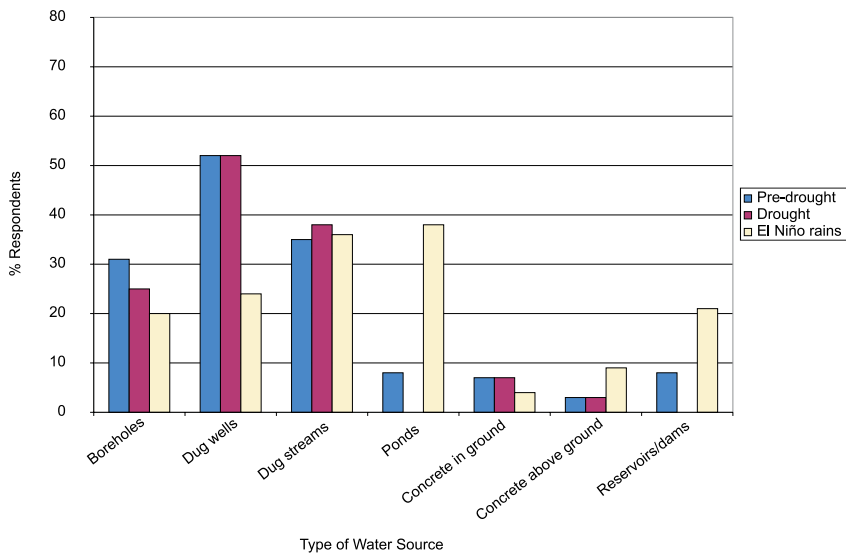

Figure 3. Percentage of respondents in S. Kenya agro-pastoral subzone utilizing different kinds of water sources.

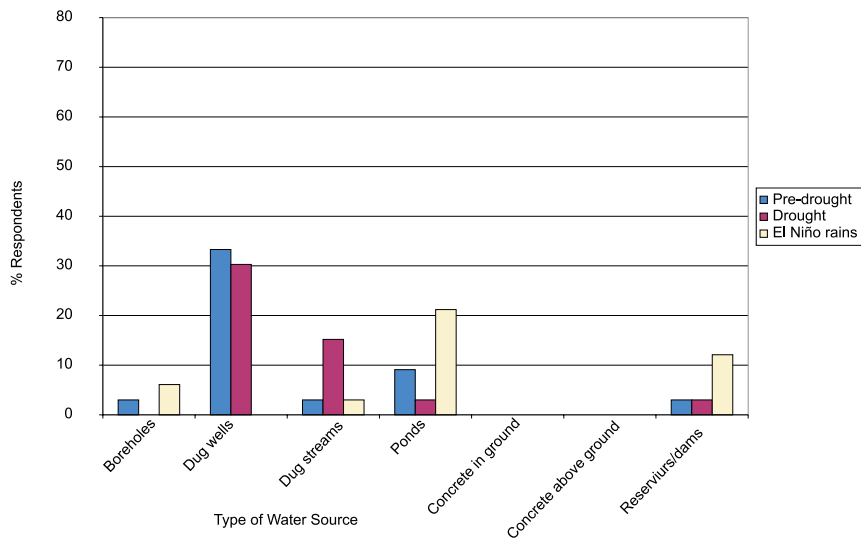

Figure 4. Percentage of respondents in southern Kenya pure-pastoral subzone utilizing different kinds of water sources.

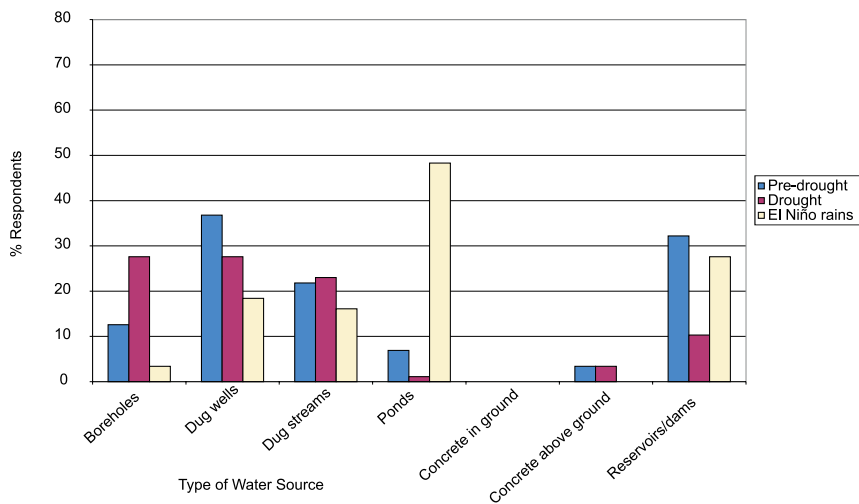

Figure 5. Percentage of respondents in northern Tanzania agro-pastoral subzone utilizing different kinds of water sources.

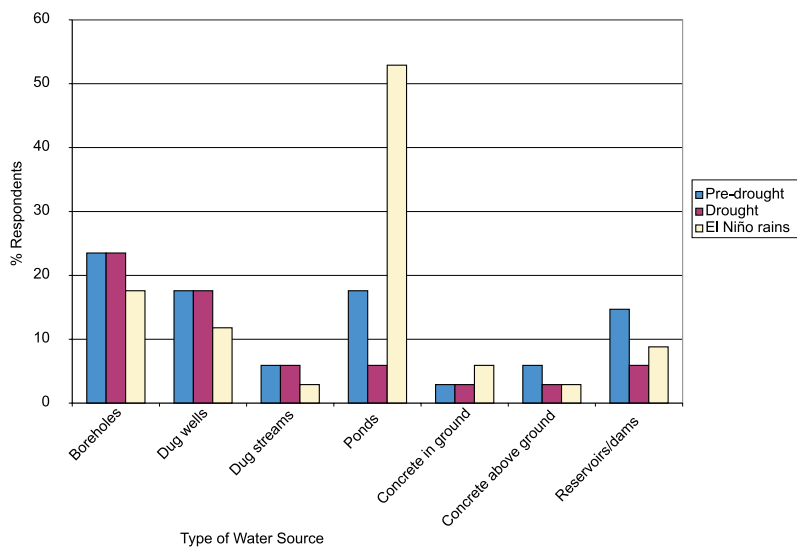

Figure 6. Percentage of respondents in northern Tanzania pure-pastoral subzone utilizing the different kinds of water sources.

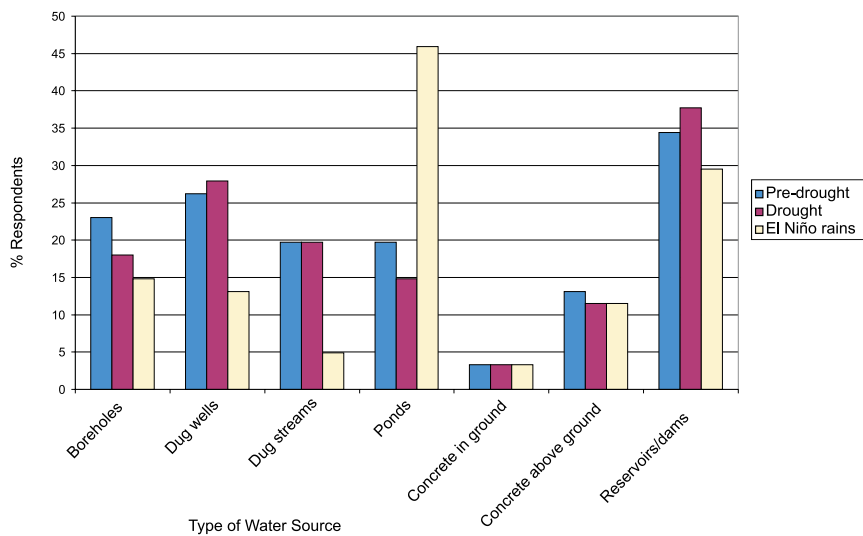

Figure 7. Percentage of respondents in central Tanzania utilizing the different kinds of water sources.

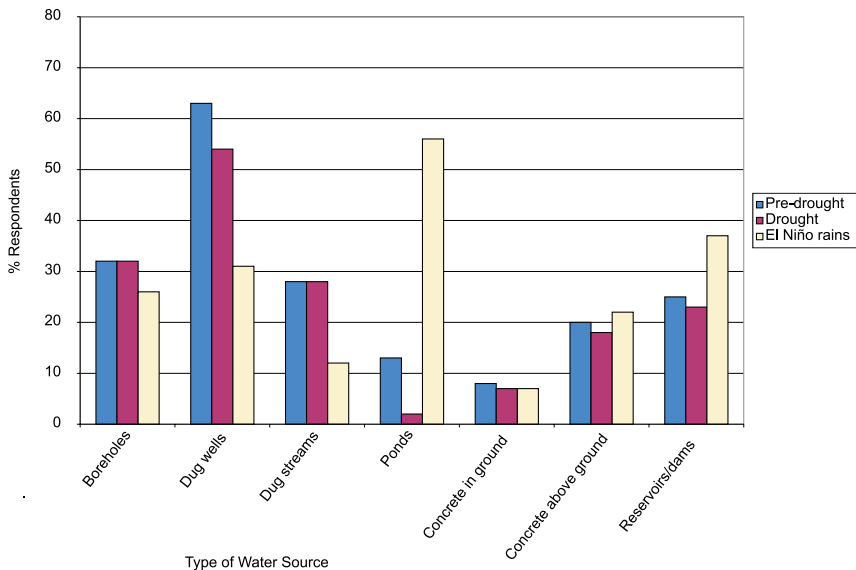

Figure 8. Percentage of respondents in northwestern Tanzania utilizing the different kinds of water sources.

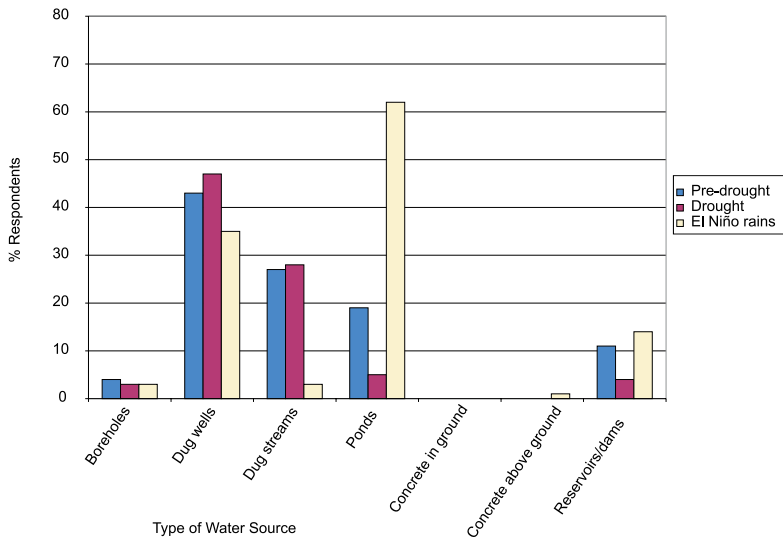
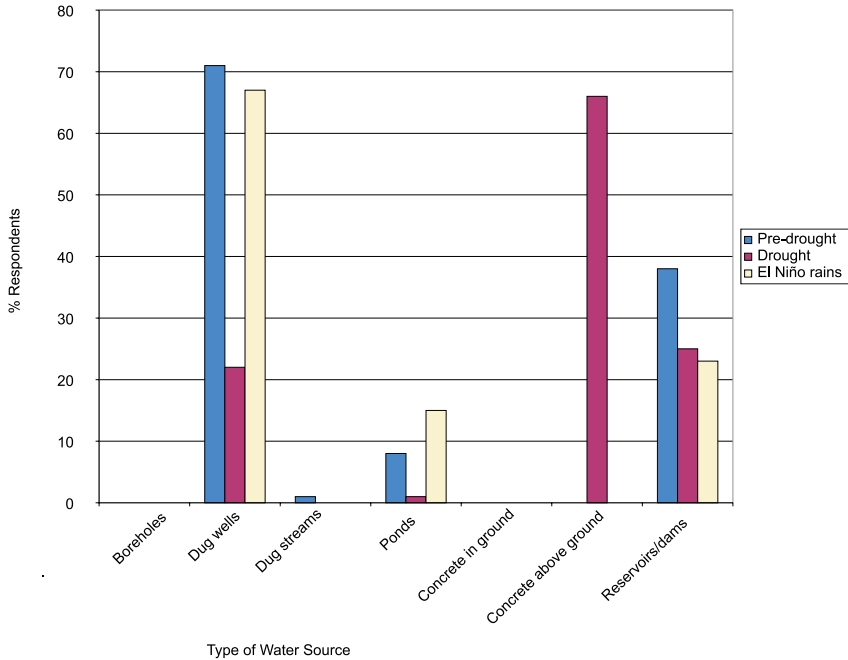

Figure 9. Percentage of respondents in C/SW Uganda utilizing the different kinds of water sources.



### Literature Cited

Coppock, D. L. 1994. *The Borana plateau of southern Ethiopia: Synthesis of pastoral research*. Synthesis of Pastoral Research, Development and Change, 1980–1991. ILCA System Study. Addis Ababa, Ethiopia: International Livestock Centre for Africa (Ethiopia).

Dyson-Hudson, N. 1991. Pastoral production systems and livestock development projects: An East African perspective. In *Putting people first: Sociological variables in rural development*, ed. M. M. A. Cernea, 219–256. World Bank Publication. Oxford University Press. Second Edition.

Niamir-Fuller, F. 1998. The resilience of pastoral herding in Sahelian Africa. In *Linking social and ecological systems: Management practices and social mechanisms for building resilience*, ed. F. Berkes, C. Folke and J. Colding, 250–284. Cambridge University Press.

## Part 3

### Community Management Issues in Smallholder Irrigation



# Smallholder Management of Irrigation in Kenya

*Wouter Scheltema*<sup>1</sup>

## **Abstract**

Indigenous smallholder irrigation still exists in Kenya. After a period of outside impulses and top-down inputs to smallholder-managed irrigation, the emphasis now is on participatory design and farmer-driven irrigation development. Cost-sharing and cost-recovery have been introduced and credit schemes developed. Smallholders manage half of the area under irrigation. Smallholder irrigation systems are characterized by small subplots of 0.25–1 acre, while the family is also engaged in rain-fed agriculture and livestock keeping. In smallholder horticultural schemes, the irrigated plots of various farmers are on the “main” farm and, therefore, not adjacent to other irrigated subplots. In rice schemes, irrigated subplots are concentrated in the lowlands, while other agricultural land and houses are on a higher elevation. Pump-fed schemes have not been sustainable. Gravity-fed schemes are sustainable and economically feasible if high-value cash crops are grown under intensive production systems. Participatory design has been achieved through step-by-step discussions of the issues before implementation. Operational (cash) requirements need to be clarified before farmers start with their implementation contributions. Farmers’ involvement in design and in choice between systems was found to be feasible under conditions of cash contributions to the investment. A minimum of low-key follow-up support on a cost-recovery basis is recommended.

## **Introduction**

Smallholder irrigation constitutes an important part of the total irrigation activities in Kenya. As in the coffee and tea production, smallholders have a major share in the irrigated produce of rice and vegetables. Smallholder irrigation has existed as an indigenous practice for several centuries. Scheltema and Osoro (1990) reported that smallholders manage about one-third of the total irrigated area. This share has now increased to one-half. At the same time, the area managed by the only irrigation parastatal (National Irrigation Board [NIB]) has decreased as farmers took over the largest scheme themselves (see paper by Kabutha and Mutero on Mwea). Other agency-managed schemes (Bura and Hola) along the Tana river stopped operating. Commercial irrigation shifted its emphasis from coffee to horticulture and floriculture, where it presently occupies 40 percent of the irrigated area.

Most of the indigenous smallholder irrigation schemes that have existed for centuries continue to date one way or another. For many years, the main impulse for change came to smallholder irrigation development from outside. The first one was from Arab influence along the coast and later impulses came from bureaucrats and projects from outside the farmer

---

<sup>1</sup>Consultant.



communities in a top-down approach. Thereafter, in a transition period, outside assistance was provided to promote farmer participation in irrigation development. Farmer-driven smallholder irrigation development emerged only recently. It is characterized by actions taken by individuals making use of small pump/engine systems, treadle pumps, and small gravity-fed drip systems (see paper by Sijali and Okumu).

Development of estate irrigation started in the colonial era with fodder production on ranches for livestock feeding in the dry season. After independence in 1964, most of these ranches were subdivided. Rice irrigation started under the colonial government and was continued after independence in centrally managed schemes. Sprinkler irrigation of coffee plantations and one large pineapple plantation started in the seventies and eighties. Large-scale sprinkler and drip irrigation of vegetables and flowers started in the late eighties and continued in the nineties.

## **Smallholder Management in a Historic Perspective**

### ***Indigenous Irrigation***

Three major forms of indigenous smallholder irrigation were practiced:

1. Diversion systems with furrows
  2. Diversion systems with flood flow
  3. Water harvesting systems
1. Water was diverted from rivers and conveyed through earthen and rocky canals to the agricultural area where on-farm application was through wild flooding. This practice was found in the Taita hills and it was widely spread along the western escarpment of the Rift valley (Elgeo, Marakwet and west Pokot districts). These furrows started at the top of the escarpment, conveying water 1,500–2,000 m downward, to irrigate food crops at the foot of the escarpment in the Rift valley. These systems were elaborate and included temporary diversion weirs, and crossings of rivers and furrows of neighboring clans. Some are still operating or have been rehabilitated. In their original form they were labor-intensive due to the need for continuous repair of structures and the daily patrolling during the irrigation season. With a strong clan structure and in the absence of other reliable alternative sources of livelihood this has been a sustainable system for a long period of time.

That irrigation is indigenous does not automatically mean that it is still feasible and sustainable as was reported, among others, by Klinken (1986). On the contrary, the weakening of the social structure has created a strain on the labor-intensive O&M, which tend to exceed present capabilities. Therefore, the production of irrigated food crops is often infeasible any more. In areas with easy access to markets, a transition has been made to irrigation of high-value cash crops (e.g., Ortum and Sigor in west Pokot). Deforestation in the catchment areas has decreased low flows during the dry season and it is this low flow that is used for

irrigation to benefit from the absence of rain-fed crops in the markets. Although investment in water-saving measures, such as lining of canals and implementation of permanent structures, is possible and has attracted donor funding, the question of economic viability was often avoided, by accepting minimum contributions from the farmers. Other alternatives for investment have to be considered as well, as irrigation of food crops is often not economically justifiable. When farmers cannot pay for future maintenance costs, the system should be considered unsustainable.

2. Indications of flood-flow diversion have been found at the bottom of the Rift valley in an area near the Baringo lake (Ol Arabel river).
3. Water harvesting for crop production was practiced, and still occurs in small depressions with natural overflows on the west side of the Turkana lake. The expansion of water harvesting, through the erection of bunds for water harvesting, has not been successful for the production of food crops. Studies in Baringo by Smith and Critchley (1983) and BPSAAP (1984) show that strip water harvesting for smallholders has not been successful but that possibilities exist for large-scale crop production. West of the Turkana lake 1-1.5 m high bunds were used in another program. With a low annual rainfall probability, most sites do not harvest water every year. The required discipline for strict maintenance of bunds and overflow sections by people who are predominantly nomadic in lifestyle is not appropriate. Subsequent heavy overland flows have often destroyed the water-harvesting infrastructures.

### *Impulses from Outside the Country*

The first outside force was the Arab influence. The Arabs came from Oman and traded along the coast and settled there. They promoted the production of rice. Tidal fluctuations were used to irrigate rice in the mouth of the Lower Tana, where fresh river water raised during the high tide was diverted to rice plots along the river, that were surrounded by small dikes. In the late eighties, 600 hectares of rice were grown in seasonal lakes and along the riverbanks in the Tana delta. In the Vanga area in the Kwale district along the Uмба river, water was diverted to scheme areas at some distance from the river. Even now, landownership is still with the descendants of the Arab settlers while the farmers are tenants. Changing flow regimes in the Uмба river through deforestation in the Usambara mountains in Tanga Tanzania have resulted in scouring of the riverbed due to increased flood flows. It is not possible to divert water through simple temporarily constructed diversion structures, and the absence of clear landownership of the tenant farmers makes investments in permanent structures questionable.

The second outside impulse was the construction of the Ugandan railway, through Kenya, at the end of the last century. Laborers were contracted from the Indian subcontinent. During and after the railway construction, they started irrigation schemes for growing Asian vegetables, using their indigenous knowledge. In the Kibwesi and Mtito Andei areas springs and streams fed from the Chyulu range were diverted for use in a number of irrigation schemes. Specialization in Asian vegetables continues to date, although now it is in the hands of indigenous Kenyan farmers (e.g., schemes such as Mutitu, Kiboko and Vumillia).

The third outside impulse came during the Second World War when the colonial government required food for the British army. The government promoted the production of vegetables around Karatina in the Nyeri district and constructed some simple diversion structures (e.g., Ihwagi scheme) that are still in use. In addition, rice production was promoted in the Kano plains. The Uhuru floods, just after independence, destroyed most of these schemes. In the late fifties, the colonial government made use of Mau Mau detainees to develop irrigation schemes (e.g., Hola along Tana river, Mwea in Kirinyaga and Yatta furrow in the Thika district). The Tana river changed its course in the nineties and Hola was cut off from its water supply and irrigation activities were stalled. However, Mwea (see Kabutha and Mutero paper on Mwea) and Yatta furrows are still operational.

### ***Top-Down Irrigation Development***

*Centrally managed schemes with tenant farmers.* After independence in 1963, the Government of Kenya promoted rice production through centrally managed schemes with tenant farmers. New schemes were implemented in western Kenya, such as Ahero and west Kano in Kisumu and Bunjala in the Busia district. For the development of the Ahero scheme, land already under cultivation was confiscated and some of the original farmers returned as tenants. These schemes still exist but their organization is outdated because of the position of farmers as tenants. Also, the high service costs resulting from inefficient services by the central agency (water, land preparation, spraying, milling and selling) were untenable. Sprey (1984) posed the question whether tenants of the pump-fed centrally managed schemes could pay the real costs, which even then was impossible. Large areas suitable for tenant management systems became scarce. Eviction of smallholders for centrally managed schemes with tenant farmers was not feasible any more. An attempt to expand the gravity-fed Mwea scheme in the nineties failed for this very reason, although funding was already secured.

*Settlement of pastoralists.* In the seventies, irrigation schemes were constructed to settle pastoralists in Turkana, Garissa, Isiolo and Mandera. Indicative of the absence of any form of participation is the famous story of the FAO specialist who, with all good intentions, decided upon the location of a scheme by viewing the land from a small plane. Examples are Katilu and Morulem in the Turkana district, First Farm in the Garissa district, BP1 and Shantole in the Mandera district, and Merti and Malka Daka in the Isiolo district.

The gravity-fed schemes in Turkana are located along seasonal rivers with a high sediment load, which requires heavy labor input to excavate deposited silt in canals and to reconstruct temporary intakes. Most of these schemes have failed due to the relatively low additional benefits compared with rain-fed production (Asman et al. 1987) and the absence of effective farmer participation. The pump-fed schemes in Mandera, Garissa and Isiolo required continuous government assistance in O&M.

Some donors, such as NORAD in Turkana and several international NGOs joined in these activities and attempted to involve the potential farmer-pastoralists in the O&M from the start. The pastoralists' schemes were combined in a minor-irrigation program managed from Nakuru in the late seventies. Hogg (1983) has already reported on the Isiolo schemes. The Ewaso Ng'iro North river runs dry in some years due to deforestation and abstraction for irrigation in its catchment area (Aberdares and Laikipia; see Gichuki paper). Consequently, most schemes in Isiolo are abandoned.

*Creation of an administrative presence in less-secure areas.* Bura, a large-scale centrally managed scheme was implemented in the eighties with the objective, among others, of settling landless people mainly from central Kenya and of increasing agricultural production. In addition, it created an administrative presence in the lower Tana area, where security was, and remains, a major concern. Due to high operational costs, inefficient O&M of the pumping station and lower-than-expected yields, among others, the 6,000-hectare Bura scheme has never been in full operation and is now abandoned.

*Technically motivated schemes.* In the late seventies and early eighties, plans for irrigation development originated with the River Basin Authorities (Tana River Basin Authority in eastern Kenya, Lake Basin Authority around Lake Victoria and Kerio Valley Authority in northwestern Kenya) and the Ministry of Agriculture (Irrigation and Drainage Branch: [IDB]). The basis for scheme development was the physical opportunity for irrigation, such as availability of water, suitable soils and suitable topography. Technically oriented guidelines—MoALD 1986 and manuals MoALD 1984–1990—were developed. First, programs were designed and, later explained to the community in public meetings called by the chief. The chief is a government employee, with powers to arrest, impose a general fee, a fine, etc. Farmer participation was restricted to say “yes” at this public meeting. Moreover, a “yes” vote was in favor of the most obvious component: the creation of employment opportunities for casual labor during implementation.

*Gravity-fed canal irrigation schemes.* These schemes have been implemented mainly for rice production in the Nyanza province, for food production in the Rift valley province and food/horticultural production in the coast, central and eastern provinces.

Examples of *gravity-fed sprinkler-irrigation schemes* for horticultural production are Mitunguu and Kibirigwe. In the latter case, support from the administrative police was required during the topographic survey, as the farmers were afraid the government would confiscate their land. Although heavily supported for 3 years after implementation by the project, with extension and marketing, Kibirigwe is only 60 percent operational. The Mitunguu scheme, with 6 years of follow-up support in extension and FO, finally became fully operational.

*Tana delta village rice-irrigation program.* For the Lower Tana area, a special program was set up to promote pump-fed village rice-irrigation schemes. Participation of farmers was minimal. Rice production was less profitable in the schemes than by individuals outside the schemes, although outside production was limited to a few places along riverbanks and a seasonal lake. Moreover, the financial and technical management of pump systems was a heavy strain on the organizational capacities of the farmers. The river changed its course and traversed one scheme (Mnazini). Two others schemes, Wema and Hewani, were cut off from their pumping stations by a new canal for the Tana river rice scheme. In the end, none of the schemes of this program have survived, with the 1997–1998 El Niño floods breaking the camel’s back.

*Pump-fed irrigation with groups.* In terms of development assistance, it is tempting to provide groups of farmers with a pump-fed irrigation system, especially if farmers have taken some initiative. For example, the formation of women’s groups was encouraged to attract donor funds.

Other groups were producing vegetables with bucket irrigation. In the early eighties, altogether 40 such schemes were counted in the Nyanza province alone, all being now abandoned. The attractiveness of its quick and easy implementation and sometimes the focus on women's groups easily generated donor and political support. However, the management of a pump-fed system by a group is often beyond the capabilities of the farmer community. Fee collection for O&M of the pump and its prudent use are often difficult. Farmers can only make a profit, after reduction of costs for the pump and inputs, if they quickly adopt an intensive-production system. They have to achieve high yields and time their planting for marketing when demand is high. An individual farmer may achieve this, but to reach this production level as a group is very difficult. If some farmers are not able to contribute, others stop as well. All these irrigation schemes failed as a result of a top-down approach. Schemes failed even if they received the best in terms of farmer's preparation, training and follow-up. The few exceptions in Garissa have been achieved only after 15 years of assistance with crop extension, provision of fuel, and repair/maintenance of engines and pumps. Their location in the center of an arid area with a ready market for a wide range of produce has also contributed to their ultimate sustainability.

*Individual pump-fed irrigation.* Individual pump-fed irrigation with a small petrol or diesel engine has a better perspective than group-based schemes. A special manual for individual pump-fed irrigation was developed by MoALD (1990b).

## **New Approaches**

### ***Farmer Initiatives***

In addition to the outside interventions described above, farmers started to develop their own schemes. A few representative but not exhaustive examples are given below:

*Ranch furrows.* After independence, most ranches were subdivided for smallholder settlement in the late sixties and early seventies. Some of these ranges had irrigation furrows, directly diverted from rivers, to produce fodder in the dry season through wild flooding. These furrows were transformed by smallholders for irrigation of crops. Initially, food crops (maize) were grown and, more recently, there has been a shift to horticultural crops (Laikipia, Nyeri districts).

*Mountain furrows.* Farmers in the foothills of Mt. Kenya (mountain or island scheme) and the Aberdares organized themselves to divert water from small streams. Furrows were excavated by manual labor in 1–2 day per week over a period of 1–3 years. The technical assistance consisted of a local extension worker with a line level, resulting in an average slope of 0.1 percent and furrow lengths up to 10 km (Embu, Nyeri, Meru, Nyandarwa, Kirinyaga, Nthii districts). In steep sloping areas, farmers take water from the earthen furrow through 1-inch pipes, which provide them with an almost equal flow, irrespective of the length of the pipe.

*Rice schemes in the Kano plains.* After the destruction of the rice schemes by the "independence floods" (see section under Impulses from Outside the Country, p.173) farmers used their experience to develop new schemes. Small streams, rivers and tail water from the

Ahero NIB scheme were diverted to impound water for rice production (Kano plain rice schemes, Kisumu district). The water supply was not secure and water distribution was organized on a first-come first-take basis. In addition, some diversion canals were eroded into drains by floods (“old” Gem-Rae).

*Bucket irrigation along Lake Victoria shores.* Small irrigation plots were established, predominantly by women’s groups, and irrigated by buckets along the shores of Lake Victoria. Production and income are based on subplots cultivated by individuals. The labor-intensive method of irrigation restricts the cultivated area. The opportunity created through the allocation or hiring of a plot by the women’s group brought about a strong commitment by the women. On an individual and customary basis, they would not have been allowed to keep the proceeds from their produce (Siaya, Homa Bay districts).

### ***Participatory Design***

In the late eighties, the Ministry of Agriculture realized the problems encountered in promoting smallholder irrigation development. New guidelines were developed first in draft form and, after testing, they were formalized by MoALD (1993). In the beginning, the engineers assumed that the farmers could not understand the design or the functions of the structures and explanation followed after implementation. Even engineers seldom considered design alternatives among themselves. Then a participatory planning method was developed, in which the farmer’s participation was made manageable by distinguishing individual steps. The individual steps were:

- inventory
- agreement on surveys
- FO
- participatory layout of canals and drains
- O&M
- contribution to implementation
- implementation agreement

In the first step, the farmers show engineers the site of the scheme they had in mind and give information on the ideas they have about the scheme. The farmers are asked how they expect the water to reach their farms and how they want to be grouped in units or blocks. Alternative sites for diversion weirs may be visited. The agency staff prepares a document with terms of reference and cost estimates for the required surveys.

In the second step, the terms of reference and the estimated costs for a topo-survey are discussed with the farmers. Alternative sites for an intake, alignment of main canal and scheme area will be part of the topo survey. Where land has been used for grazing or other nonagricultural purposes a soil-suitability assessment is required. Consequently, the costs for a first soil assessment and its terms of reference will be included in the discussion. In case

the proposed irrigation site is already in use for agricultural production, observations and farmers' comments on the soil suitability may suffice. Possible contractors are proposed and proposals from at least three contractors will be invited. The received proposals will be evaluated with the existing committee and a contract awarded.

In the third step, the FO is dealt with in more detail. The need to collect cash contributions from the members requires a formal organization. Moreover, the future structure of the organization, based on blocks or zones with gender-balanced representation is to be discussed and agreed upon as early as possible. Often, some kind of organization already exists. A committee may have been elected with the sole purpose of attracting attention (funds and expertise) to the village; the educated villagers who reside in towns are often elected for this purpose. Sometimes, a more general organization exists and this committee automatically assumes the role of the irrigation committee. Moreover, during implementation the committee has to carry out a much more active role than during O&M. A pragmatic solution is to expand the existing committee with zonal or block representatives, who assist in mobilizing contributions from their area. The operational committee elected after implementation will be based on zonal representation, for which all farmers, including members of the old committee and representatives are eligible.

The fourth step is the scheme design. After the surveys have been carried out, the route(s) of provisional main and secondary canals and the position of structures are pegged out in the field, followed by the engineers and the farmers walking along this route and eventual discussions with the group. Amendments are made where needed and used to assign the preparation of a scheme design with possible alternatives.

The fifth step is to discuss the task of O&M with the farmers, translated into number of days and the amount in cash each farmer would contribute. If applicable, the cash requirements for O&M of pump, engine and pipes are included. In rice-growing schemes and more so in horticultural schemes, the input requirement is of importance. To make the scheme to become economically feasible, farmers need to intensify their production practices. The additional effort of labor and cash required, above what was needed for rain-fed agriculture, are to be largely compensated for by the profit generated from the sale of produce. The traditional attitude in rain-fed agriculture is characterized by risk aversion in anticipation of water shortages. Farmers have to adopt to a more intensive production system that requires an investment in certified seeds, manure, fertilizer and sometimes pesticides, while labor requirements will increase through gap-filling, timely weeding and crop-protection measures. At the end of this step, farmers have a more realistic picture of what kind of commitments they are required to make. The choice between alternative designs becomes then more apparent to the farmers.

In the sixth step, the farmers' contribution towards implementation in cash, labor and materials is discussed. This includes the estimated number of labor days required for excavation and collection of local materials, and the number of days per week farmers are willing to contribute, in which often market days are excluded. Initial cash contributions are required if farmers have chosen a design that requires cash contributions for O&M. This is to test their capability and organizational capacity in dealing with the financial consequences. Then they have to contribute the required cash during monthly meetings over a period of 6 months organized at the smallest unit. This will put a heavy strain on group cohesion, and coping mechanisms have to be developed, which are better tested prior to, rather than after,

construction. The minimum cash contribution is best set at twice the monthly cash contribution expected for the scheme when operational.

The final or seventh step is a written agreement between the farmers (committee) and the implementing agency. The farmers' contributions and time commitments as well as the obligations of the implementing agency are specified. Adherence to the agreed time schedule should be conditional and the agreement should be automatically canceled if delays occur beyond agreed periods. The contributions from a donor, if applicable, are specified in terms not only of materials and cash but also of technical assistance, costs of the number of visits, etc. Agreed meetings between the implementing agency and the committee or farmers' meetings should be adhered to, as otherwise the cost incurred has to be compensated for.

### ***Development on Credit***

In the early nineties, donor interest in smallholder irrigation in Kenya was lessening and it was foreseen that farmers had to make their own investments. Financial institutions were not interested in making loans for this sector. Agreements were tried out with the Cooperative Bank, Industrial and Commercial Development Corporation (ICDC) and Victoria Finance. However, the formal financial sector did not perceive smallholder irrigation loans, based on group guarantee, as their core task. Therefore, they did not give it the required attention. Moreover, lenders expected a security of 80–110 percent. As a result, all contracts performed poorly. In spite of these earlier disappointments, IFAD recently entered into a new contract with the Cooperative Bank and AfDB with the Agricultural Finance Cooperation (AFC) for their smallholder irrigation programs.

The informal banking sector is involved in short-term loans concentrated in larger rural towns and does not provide loans for agricultural purposes. To deal with this situation an informal credit organization called Smallholder Irrigation Scheme Development Organization was formed to provide loans on the basis of group guarantee as outlined by Scheltema and Mirero (1990). Loans were provided for irrigation activities, such as production inputs, small petrol pumps, and infrastructure of group schemes. The groups take responsibility for deciding on the supplier (inputs) or contractor and sign agreements. The Irrigation and Drainage Branch provides them with technical support, while agreements under credit provision have to be approved by the financial institute. Except for individual pump-loans secured through group guarantee both input loans and small-size scheme-infrastructure loans have performed well. However, the management performance has been variable and the organization has still to prove its value. Other organizations such as FPEAK (see Nggi's second paper) have recently started to provide credit for input loans based on an export production contract with one of its members.

### ***Agency Support***

The transition from handouts to development on a cost-sharing or cost-recovery basis meets most resistance from staff of government agencies and less from farmers. Engineers determined the design components and their construction standards were high. However, in the new participatory design approach, farmers are the ones to decide. For example, farmers chose between a river/gully crossing constructed from removable corrugated iron sheets or as a fixed piped crossing on pillars. The farmers' decision should be based on advice regarding advantages and disadvantages of various options provided by the engineer and by advice from other farmers during farmer-to-farmer visits. In addition, the decision-making process should also



consider the willingness of the farmers to participate in cash contribution. Without a cash contribution farmers will not fully own and utilize the scheme. Moreover, they would be excluded from discussions of the underlying business issues.

The position of the agency staff also changes drastically. Instead of distribution of the “goodies” the staff is now being challenged and called to task in addressing farmers’ demands. The staff members are literally left empty-handed and have to find a new way of relating with farmers. Training is required on how to change the mode of operations and how to speak *with* farmers instead of *to* farmers. Engineers, with their technical background, are inclined to avoid chaos and to keep the situation under control. This is difficult to achieve in a farmer meeting where emotions play a role. To minimize chaos and to allow the engineers to conduct a meeting as effectively as possible the seventh-step approach as outlined in this section was adhered to. New developments, with a focus on designing for farmer’s management have been emphasized in workshops already since Kortenhorts 1983, and further stressed by MoALD (1992, 1996); and Chancellor and Hide (1996). More recently, the emphasis shifted to strengthening the FOs’ irrigation schemes (GoK-JICA 2000).

From the mid-nineties, the role of the government in implementation has diminished and the government started to concentrate on core tasks: to monitor, coordinate and supervise contractors. Activities such as surveys, design and construction were more and more contracted out. To contain expertise in the IDB a design team was formed, which could carry out a few designs but mainly supervise the design work of others. At first, the IDB did the contracting out countersigned by the farmers but, at a later stage, farmers became the clients in the contract. For supervision of the implementation, farmers may require technical assistance, which they can hire or request from the IDB. It is seen as a logical consequence that those who contribute in cash have an overruling say in the contracting procedure and the selection of the contractor. With farmers’ supervision of the contractor, the problematic issue of handing over of the scheme after completion disappears, as it was theirs from the beginning.

Farmer-driven irrigation development is more recently promoted through small gravity-fed drip irrigation kits fed from a bucket or drum (see paper by Sijali and Okumu). Together with the use of small petrol- and diesel-driven pumping systems and the treadle pump, it provides individual smallholders with the potential for more profits than is possible through group irrigation.

## **Present Characteristics of Smallholder Irrigation**

Today, smallholder irrigation consists mainly of group schemes with gravity-water supply, in which high-value cash crops (horticulture, floriculture) or rice crops are grown. Rice cultivation is restricted to the heavy clay soils (black-cotton soils), which are less suitable for the more profitable high-value crops. Production of food crops in irrigated areas in pastoralist areas has declined or has been transformed to production of horticultural crops. Individually managed irrigation consists of only 10 percent of the smallholder area, the water supply is manual (bucket) and pump-fed (portable pumps) from open water sources, and the production concentrates on horticultural crops. The use of groundwater is an exception in smallholder irrigation. Boreholes and tube wells are used by commercial irrigators for the cultivation of fodder, flowers (roses) and horticulture.

The government sees political support for irrigation as a means of dealing effectively with food-security problems. However, the cost of irrigation schemes is prohibitive for the production of food crops such as maize. Irrigation is only economically viable if high-value cash crops are produced. With low levels of investments, rice production may be viable as well (for example, Kano plains in the Kisumu district). High-value crops may range from those that can be stored for short periods of time, such as onion, sweet potato and pepper to more perishable crops such as tomato, spinach and Asian vegetables. These crops are grown most profitably in the dry season to offset the larger supply by rain-fed producing areas. The income derived from the produce enables farmers to buy food. However, often only a small portion of the community has a plot in the scheme. To solve the problem of deficiency in food crop production, appropriate measures have to be taken to improve rain-fed food production.

### *Irrigated Horticulture*

Smallholder irrigated horticulture is a highly diversified cropping system. A wide range of crops is grown in the irrigated plot with 2–3 crops per year. Moreover, the irrigated plot occupies only a (small) part of the farm on which rain-fed agriculture and livestock productions are practiced as well. Average smallholder farms range from around 1–2 acres in high potential areas (rainfall > 800 mm/year) to 5–10 acres in low potential areas (semiarid). The irrigated plot size varies from 0.25 to 1 acre in most schemes. Labor requirements in horticulture and floriculture are high: a family of four laborers is required to cultivate half an acre. Labor requirements in person-days per acre per year are given by MoALD (1990a). They vary per crop under irrigation: French bean 525, cut-flowers 400, chili, okra, tomato, onion, carrot, cabbage, kale, cotton, brinjal and Irish potato 220–280, rice and sweet potato 175, coffee and banana 100, maize, millet, sorghum and bean 70.

The above-mentioned nationwide study showed a decreasing order of profitability: a) cut-flowers, b) tomato and kale, c) onion, brinjal and leaf vegetables, d) chili, French bean, cabbage and Asian vegetables, e) coffee, banana, sweet potato and okra, f) rice, g) cotton, Irish potato and millet, and h) local maize, cassava, sorghum, hybrid maize and bean. A large part of the brinjal, chili, French bean, Asian vegetables and coffee are exported while the other produce is consumed in Kenya. Irrigated produce is marketed in the dry season when the produce of rain-fed areas is minimal. Marketing studies by Caritec (1992) show an increasing demand for horticultural crops in the bigger towns due to an increasing population. Oversupply in the dry season is not expected to be a problem in the near future.

Farmers irrigate only a portion of their land, while the irrigated plots of the various farmers are nonadjacent. Reallocation of land to allow the formation of a more compact irrigation scheme is not acceptable to farmers. Land rights are very sensitive and farmers reject any possible infringement. This has negative repercussions on water efficiency in earthen canals as they have to be longer, and water losses are relatively high. In the new schemes, there is a tendency to pipe water by gravity. In such a case, the negative repercussion is not the loss of water but the larger investment of the longer pipeline required. An environmentally positive implication is the lower concentration of leached fertilizers (nitrogen) and pesticide residues in the groundwater, as this is spread over a wider area compared to a concentrated scheme.

Moreover, ample potential opportunities exist for integrated disease and pest management as a crop is grown on a small area in isolation from the same crop in fields further away. However, extension services have not yet emphasized the newly introduced integrated pest

management approach and farmers have not adopted the more complicated approach. The handling of chemicals used for disease and pest management in the field and their “storage” in the kitchen constitute a main concern (see paper by Sithanatham et al.).

### ***Economic Feasibility***

Feasibility studies of irrigation schemes tend to approach the economic viability of a scheme from the point of view of an average farmer. In these studies, the costs and the benefits for the scheme are compiled and divided over the total irrigated area to derive an average profitability value per hectare. However, as the average farmer does not exist, the value of these studies is marginal. Farmers are “selected” on the basis of plot ownership in the command area and not on their farming capabilities. Therefore, a wide range of variation in the performance of irrigation farmers can be expected. In the age of cost-sharing, cost-recovery and farmers taking loans for scheme development, the variability in farmers’ skills is relevant. It is important to estimate the profitability of a poorly performing farmer and his capability to address family cash requirements as well as cash needs for irrigation. This exercise is to ensure that his or her livelihood is not adversely affected by participation in the irrigation scheme and to prepare mitigating measures to offset nonpayment by a poor-performing farmer. The issue of the possible occurrence of poor performers has to be addressed in advance of the scheme development, by the farmers and, if applicable, by the credit institutes. Group credit schemes in which members guarantee the loans of each other, need to deal with members who cannot meet the loan repayments. One of the options is to shift the allocation of water temporarily from the poor performers to good performers in the same group.

*Rehabilitation versus development of a new scheme.* Farmers’ participation in new schemes is relatively easy as all farmers have the same objective of getting access to water for irrigation. To achieve this, they are more willing to share the cost of implementation and the water charges. The greatest obstacle is in the improvement of existing schemes. These are often constructed by a small group of farmers who did not discuss rules of O&M in advance. Those farmers closer to the water source tend to take more than their share. Those farmers, who contributed in the same way to the construction of the “furrow” but are further down (tail enders), do get proportionally less and sometimes no water at all. Farmers who have been “stealing” over a longer period do not like to give up their advantaged position. They are often not prepared to share water thus resulting in inequality and conflicts.

*“Tail-to-mouth” and “economic bias” approaches in rehabilitation.* In Kenya, rehabilitation is still approached as a one-time affair in which a scheme has to be upgraded in one operation. In Tanzania, the Traditional Irrigation Programme (TIP) has gone a step further and has developed a step-by-step approach for existing, traditional schemes. They have developed the “tail-to-mouth” and the “economic bias” concepts. In an existing scheme, first, farmers have to improve their on-farm irrigation (“tail”) to enhance the efficient use of the little water they receive. Improvement is achieved through terracing and/or basin and furrow irrigation. In addition, under the “economic bias” concept, the farmers are to intensify the production on whatever small area they irrigate. They are encouraged to use manure, make nurseries, fill gaps after transplanting and to weed in time. The effect is increased production that is translated into cash income prior to the rehabilitation efforts. From these proceeds, farmers can value

further improvements and can contribute in cash to a next step of scheme improvement. The next step is governed by the answer to the question “what relative small investment (something farmers can now afford) will have the largest effect on production?” Often, a distribution structure or a gully crossing is selected. It is only as a last step that the most expensive structure, the offtake from a river or diversion weir (mouth) is tackled. This allows the farmers to make immediate use of the expensive structures as they have already optimized their on-farm production and internal distribution system.

*High-potential versus low-potential areas.* Often, there exists specific views on the priority of irrigation development in high-potential areas (high altitude, high rainfall and low evaporation) versus low-potential areas (low altitude, low rainfall and high evaporation). High potential areas are considered to be already well favored by nature and would require less support. However, farms may be small and intensification of the production would improve livelihoods in those areas. Moreover, farmers are already used to more intensive cropping systems and have experience with horticultural production during the rainy season.

Low-potential areas constitute a less-favorable environment and are considered more deserving for support. However, irrigation development in these areas is often more difficult than expected. Water development is more complex; gravity-fed irrigation requires huge investment in diversion weirs (e.g., wider, deeper and larger rivers with less suitable sites for weir construction) and longer supply canals (low head available). The farmers are less used to agriculture, in general, and to horticultural crops, in particular. Therefore, they would require more training and time to transform into intensive horticultural producers. Sources of input supply and markets tend to be further away and less accessible. Consequently, a longer period of follow-up in (horticultural) crop husbandry, on-farm water management and scheme organization is required. These costs need to be considered and incorporated in total project costs and in any feasibility assessment. Incorporation of these costs is also required when comparing smallholder irrigation development with other development options.

## **FO and Management**

### ***Registration***

Farmers in each scheme are organized in a WUA registered with the Ministry of Water Resources by virtue of application for a water permit through the district Water Bailiff. Registration can also be as a self-help group with the Ministry of Social and Cultural Affairs, in order to open a bank account with the Ministry as a cosignatory.

### ***Organization for Farmer Management***

During construction as well as for O&M, the zonal or block organization is a viable concept. Mass organization of farmers for construction often puts a high strain on the organizational capacities of the committee. Registration is cumbersome and group responsibility is often low. Organizing work in smaller groups, where the members know each other better, reduces absenteeism and is easier to administer. Those not present on the assigned day can send a replacement for which they compensate in kind or in cash.

In operational schemes, the committee often consists of farmers at the head of the scheme and the situation of tail-end farmers is not “known” or dealt with in the scheme committee. Representation of the basic unit in the larger units is essential for a good management. Information tends to flow easier with block representatives, especially where they comprise both men and women. Moreover, the selection of officials is less politicized and more focused on the operations of the scheme if basic units send their delegates to a central committee. It is also easier to avoid election of absentee farmers or nonfarmers when the basic units are represented.

For social consistence, the optimum number of members for intensive, effective group performance is around 20–30. In micro-credit finance, the maximum group size used is 30. For example, in irrigation schemes along Yatta furrow with a membership below 30 the author observed no water distribution problems. However, in all schemes consisting of groups of over 30 members, the whole scheme or part of it was not operational. Conflicts in larger groups have a tendency not to be addressed, as the difference in the power of group members becomes an obstacle and requires outside intervention in order to be solved.

### ***Marketing and Input Supply***

The experience in Kenya is that the management of an irrigation scheme should be the responsibility of a separate organization that deals with the “water” aspects only. The few combinations of a WUA and a cooperative society dealing with input supply and marketing have all collapsed (Kibirigwe, Mitunguu, Katilu and Kwa Chai). The combination of managing O&M and depositing funds for major repairs in the future is already a task often beyond the capabilities of the FO. The “water” function and the “input marketing” function are not generally compatible. In the WUA, all farmers are “forced” to participate. Farmers are grouped together because their plots are close to each other and they are obliged to cooperate. They may be inclined to do so when it is the only way for them to obtain water. Input supply and marketing organizations need to be organized separately with voluntary membership. Not all farmers may be interested in input supply and marketing. Moreover, members from other schemes, rain-fed producers and individual pump-fed irrigators may want to join the input/marketing cooperative. With the functions combined in one organization, the funds for future repair and replacement were used to finance input supply and marketing, which reduced their cost-effectiveness. Finally, the funds were “lost” and the input and marketing activities stalled and the scheme was left without funds for major repairs and future replacement of the irrigation infrastructure. Therefore, the two functions are better separated in two different organizations open to different members.

All over the world, farmers complain about unfair farm-gate prices. However, studies in Kenya (Caritec 1992) on the profitability of middlemen showed a reasonably low profit margin in areas where sufficient competition between middlemen occurred. It was only in one area (Kibwesi) that two exporters/middlemen, dealing in this area, obtained a high profit margin, probably due to their relative monopolistic position. A major problem in making agreements between groups of farmers and middlemen or exporters is the unreliability of both partners. Where an agreed price is temporarily lower than the market price, individual farmers in the group will divert their produce to other buyers, leaving the contracted buyer with the problem of how to satisfy his (export) agreements. On the other hand, nonpayment for produce, obtained by middlemen and exporters, does occur as well.

Farmers tend to diversify their production; they produce various crops for the local market and often select one crop for the export market. However, high market prices of tomato over a period of time tempted farmers to produce them continuously (Kibirigwe). As a result, for some years thereafter, soil-borne diseases made the area unsuitable for tomato and potato.

### ***Design for Farmer Management***

A series of manuals were prepared to facilitate farmer management of irrigation schemes. Manually operated structures with moveable parts were avoided to reduce the need for operational staff and maintenance works. This lowered the requirements for the level of scheme management. Instead of moveable gates, orifice-side weir combinations were introduced to prevent flood flows entering the scheme. Proportional division boxes were used to allow distribution of water within the scheme without the use of moveable gates. In a range of manuals for senior staff this concept was incorporated among other features, (MoALD 1989–1994; and Scheltema 1993).

### ***Water Permits***

The allocation of water permits is based on Water Catchment Boards in which government agencies are represented. Representation of WUAs or commercial water users is not yet dealt with. Water abstraction is presently not charged and consequently operational funds to administer water permits are virtually nonexistent. An abstraction fee was imposed in 1994, but revoked shortly after invoices were sent out. Water was charged per volume of water abstraction per category of water users (drinking water, irrigation water and industrial water). District water bailiffs deal with the management of water permits. Checking of offtakes directly from rivers is only carried out in extremely dry years when the Ministry of National Resources and Environment may revoke all permits for irrigation water use. But there is no incentive for farmers to use water efficiently without charges per volume of water abstracted and effective control of amounts diverted. At present, in most canal irrigation schemes, allocation is per time period (hours) and not per volume. In schemes with long earthen canals the tail enders may get half the amount of water or even less in the same time period as farmers close to the intake, at the head of the scheme, get. Charging for water abstraction would promote discussions within the scheme on allocation of water among members.

According to the Water Act, separate water allocations are made for flood flow and low flows. Scheme design is based on flood flow, to allow sufficient water to be conveyed into the scheme. The assumption is that water will be used only for supplementary irrigation. This is not the reality and farmers use water most economically when producing high-value cash crops during the dry season. Supplementary irrigation at the end of the main rainy season is a confusing concept. On paper, it appears feasible, but in reality it seldom works. Maintenance is often not carried out until the need for irrigation arises, which is only in years when the rains subside early. At such times, the time required for maintenance is too long and irrigation water comes too late or not all.

### ***Gender Issues***

In horticultural crop production, at least half the fieldwork is done by women, and in rice production it is even more so (Hulsebosch 1990, 1992). Hence, within the cultural context, it makes sense to discuss scheme implementation or rehabilitation with women. Intensification

of production in particular has to be discussed with women. Sometimes, women have a special plot on the farm that they use for food production and the men deal with cash crops. Women-headed households constitute a large number of farmer families, and include those headed by widows, unmarried women, and where the husbands work outside the farm community. Often, the latter amount to one-third or one-half of the households in the area. As men tend to discuss issues among themselves, often the relevant information does not reach the women. Therefore, gender-balanced representation from the lowest level of block or group to higher levels (scheme committee) is appropriate. The position of treasurer is often allocated to women, as men trust them to handle money better than themselves.

### ***Follow-Up on Implemented Schemes***

Participation of farmers can be quite successful if they are trained in administration, organization and technical matters related to scheme O&M. It is unfortunate when trained committees are replaced by untrained ones. Therefore, in the more complex piped gravity-fed sprinkler irrigation schemes it is appropriate to have some kind of follow-up. The donors and, certainly, credit organizations need a guarantee that schemes stay operational during the repayment period of the loan, with some options for loan rescheduling. For example, a credit organization cannot approve a loan for a portable pump unless the borrower shows proof of an insurance against fire and theft. It is in the same line that complex gravity-fed irrigation schemes should acquire a follow-up contract for technical, organizational and financial/administrative issues stipulating regular reporting to the annual farmers' meeting. Specifically for this purpose an NGO, Water Users' Support Organization (WASO), was formed, which provides these services on a cost-recovery basis (Kariuki and Scheltema 1996). However, at present the WASO deals only with supplies of drinking water to the community and not yet with irrigation schemes.

### **Lessons Learned**

Options for irrigation development should not only be technically and economically feasible but suitable for farmer management as well. Repeating past mistakes would be disappointing. Therefore, additional attention should be given to the causes of earlier failures.

1. *Farmers' participation as clients in the design and scheme construction is not only possible* but is found to be a prerequisite for the sustainability of irrigation schemes. It requires a modified approach to irrigation system design involving clearly defined steps, in which the full support and retraining of engineers are essential.
2. *O&M and scheme organization* require an agreement on follow-up services to ensure optimal utilization of the investments by farmers, donors and credit organizations.
3. *Involvement of women as members of the WUA is essential.* Membership should be open for women from both male-headed and female-headed households.
4. *Intensification of the production* requires cooperation between men and women at household level. High labor demands require men to increase their labor input and

women to be consulted on the use of revenue generated, before they will allocate more attention within their already overburdened daily schedule.

5. *Individual smallholder irrigation has not yet realized its potential.* The adoption rate of treadle pumps, small drum-fed drip systems and small petrol-driven pumps shows a remarkable potential for improving the economic benefits of farmers.
6. *Rehabilitating schemes with large discrepancies* in water distribution among their members is difficult and time-consuming.
7. *Irrigation development may assist in addressing food security issues indirectly, but it should not necessarily be considered the only or even the most appropriate measure.* Rice production in low-cost schemes obviously contributes to food security in the country, but improving rain-fed agriculture is often more cost-effective and probably has greater scope for increasing food production.
8. *Pump-fed schemes managed by groups of farmers have not been sustainable.* Although construction is easier compared to gravity-fed schemes, financial demands and organizational requirements are much higher. Neither women's groups nor mixed groups have managed to successfully sustain pump-fed operations in Kenya. Most schemes have failed even before the pump needed replacement at the end of its life span. Farmers have only been able to collect sufficient fees and to use these fees for O&M when follow-up support was provided for at least 10 years. On the other hand, individually owned pumps are growing in popularity, particularly in high-value crop production in the dry season.
9. *Combining O&M with the organization of input supply and marketing of horticultural crops should be discouraged.* It is advisable to have one organization to address the issue of water, which requires a "forced" cooperation among water users. Input supply and marketing should be cooperation by choice in which farmers organize themselves because of their common interest.

## **Future Perspective**

Farmers' cooperation in group-based schemes is sometimes a necessity to make large investments in irrigation infrastructure viable. However, farmers' cooperation and the management of an FO result in a large number of problems that have to be dealt with adequately.



## Literature Cited

- Asman, I. E.; P.C. Njoroge and B.M. Wandura. 1984. *Evaluation of the Turkana cluster*. Nairobi, Kenya: MoALD.
- BPSAAP. 1984. *Baringo pilot semi arid area project. Summary of interim report*. Marigat, Kenya: Ministry of Agriculture.
- Chancellor, F. M.; and J. M. Hide. 1996. *Smallholder irrigation: Ways forward. Guidelines for achieving appropriate scheme design*. Volume 1: Socio-economic parameters in designing small irrigation schemes for small-scale farmers. Volume 2: Case Studies OD 136. UK: HR Wallingford.
- Hogg, R. 1983. *Irrigation agriculture and development around the Ewaso Ngiro River Isiolo district*. MoALD/IDB.
- Hulsebosch, J. 1990. *Wichamo Mchele. A labour input study in a smallholder rice scheme in Kenya*. Kenya: MoALD/IDB.
- Hulsebosch, J. 1992. *Priorities of women in smallholder rice schemes, Nyanza province, Kenya*. Kenya: MoALD/IDB.
- JICA (Japan International Cooperation Agency). 2000. *Recommendation and proposals for sustainable smallholder irrigation and drainage development*. IDB-TCEP Consultation Workshop. Nairobi, Kenya.
- Kariuki, N.; and W. Scheltema. 1996. *Manual for management of back-up services to community managed water supplies*. Nairobi, Kenya: Smallholder Irrigation Scheme Development Organization (SISDO).
- King, A. 1992. *Broad survey of factors influencing the marketing of horticultural produce grown by smallholders in group-based irrigation schemes*. Nairobi, Kenya: MoALD/IDB.
- Klinken M. K, van. 1986. *Formal mistakes and informal lessons from irrigation in Kenya. The Pokot traditional furrow irrigation*. African Water Technical Conference, Nairobi.
- Kortenhorst, L. F. 1983. *Workshop on small-scale irrigation in Kenya*. Institute for Land Reclamation and Improvement, Netherlands.
- MoALD. 1990b. *Manuals for senior staff: Pump-fed irrigation*. Pump and sprinkler systems for individual smallholders and lectures notes for pump-fed irrigation systems. MoALD/IDB. Nairobi, Kenya.
- MoALD. 1984-1990. *Manuals for senior staff: Gravity schemes*. Identification and evaluation. Section I. Soils. 1984, Section II. Field visit and preliminary report. 1986, Scheme design 1990. Nairobi, Kenya: MoALD/IDB.
- MoALD. 1986. *Guidelines smallholder irrigation projects in rural development*. Nairobi, Kenya: MoALD/IDB.
- MoALD. 1989-1994. *Manuals for senior staff: Structures*. Part One: Structures to prevent excess flow in canals 1989. Part Two: Concrete and concrete products 1990, Part Three: Culverts (Road crossings) 1988. Part Four: Drop/Check structures 1994. Part Five: Division structures. 1989. Part Six: Weir design 1994. Part Seven: Surveying with a level instrument 1986. Nairobi, Kenya: MoALD/IDB.
- MoALD. 1990a. *Profitability of smallholder irrigation in Kenya*. Nairobi, Kenya: MoALD/IDB.
- MoALD. 1992. *Which way forward? Proceedings of a National Irrigation Workshop, Nyeri*. Nairobi, Kenya: MoALD/IDB.
- MoALD. 1993. *Guidelines on smallholder irrigation projects, for implementing agencies and donors*. Nairobi, Kenya: MoALD/IDB.
- MoALD. 1993-1995. *District profiles of almost all districts in Kenya*. Nairobi, Kenya: MoALD/IDB.
- MoALD. 1996. *Proceedings of a Regional Workshop on Smallholder Irrigation in Eastern and Southern Africa*. Nairobi, Kenya: MoALD/IDB.

- Scheltema, W. 1993. *Training elements in smallholder irrigation schemes (basin irrigation) for irrigation technicians*. Wageningen, The Netherlands: STOAS Foundation for the Development of Agricultural Education and Training. Book One. On-farm water management, farmer's participation, and water supply. Book Two. Physical requirements, canals, water distribution and water measurement, farmers organization.
- Scheltema, W.; B. Snellen; and C. M. Osoro. 1992. Nairobi, Kenya: The evolution of an irrigation development program for smallholders in Kenya. *ILRI Annual Report*.
- Scheltema, W.; and C. M. Osoro. 1990. *Irrigation atlas of Kenya*. Nairobi, Kenya: MoALD/IDB.
- Scheltema, W.; and S. M. Mirero, with contributions of J. de la Rive Box. 1991. *Loan scheme for group-based smallholder irrigated horticulture in Kenya*. Nairobi, Kenya: MoALD/IDB.
- Smith, P. D.; and W.R.S. Critchly. 1983. *The possibility of run-off harvesting for crop production and range rehabilitation in semi-arid Baringo*. Nairobi, Kenya.
- Sprey, L.H. 1984. *Should Ahero tenants pay the real costs of the NIB services?* Nairobi: National Irrigation Board.
- Zoebl, D.; and P. Njoroge. 1986. *Socio-economic report of the Nyandusi women horticultural project*. Nairobi, Kenya: IDB, Ministry of Agriculture, Nairobi.



# From Government to Farmer-Managed Smallholder Rice Schemes: The Unresolved Case of the Mwea Irrigation Scheme

*Charity Kabutha<sup>1</sup> and Clifford Mutero<sup>2</sup>*

## **Abstract**

For years, large-scale rice schemes the world over have experienced centralized modes of management under which farmers have been passive participants in a sector meant to benefit them. The situation has however greatly changed in the last two decades due to a global wave of economic and political changes that has increased awareness of the farmers on their rights and the need for change. The farmers have subsequently made demands for inclusion and a greater say on matters related to the overall management of such operations. The Mwea rice irrigation scheme in Kenya, which operated under this kind of system for close to 50 years, is undergoing similar changes triggered by farmer demands for a greater say on the way the scheme is managed.

The Mwea irrigation scheme (MIS) is located just over 100 kilometers to the north of Nairobi, covers about 6,000 hectares and supports about 3,200 farm families. The British Government first established the scheme in 1953 but handed it over to the Government of Kenya in 1963 when Kenya got its independence. The Ministry of Agriculture ran the scheme until 1966 when it handed over the scheme to the National Irrigation Board (NIB) provided for by the Irrigation Act passed in 1967 (chapter 347 of the Laws of Kenya). In the same year, NIB took over the running of all national irrigation schemes in Kenya.

This study traces the history of the scheme and management under the NIB, areas of conflict between the farmers and the NIB, the new management of the scheme, its strengths and weaknesses and identification of opportunities to move ahead.

## **Introduction**

Large-scale rice schemes the world over have been operated under centralized modes of management in which farmers have been passive participants in a sector meant to benefit them. The situation has however greatly changed in the last two decades during which a global wave of economic and political changes has increased awareness of the farmers of their rights

---

<sup>1</sup>Charity Kabutha is a consultant in Participatory Development and Gender Issues.

<sup>2</sup>Clifford Mutero is currently the IWMI Regional Representative for eastern Africa and the Coordinator, CGIAR Systemwide Initiative on Malaria and Agriculture (SIMA). At the time of preparing this paper, he was a Senior Scientist, jointly recruited by ICIPE and IWMI.

and the need for change. The farmers have subsequently made demands for inclusion and a greater say on matters related to overall management of the enterprises. The Mwea rice irrigation scheme in Kenya, operated under this kind of system for close to 50 years, is undergoing similar changes triggered by farmer demands for a greater say on the way the scheme is managed.

This study traces the history of the scheme and management under the NIB, areas of conflict between the farmers and the NIB, the new management of the scheme, its strengths and weaknesses and identification of opportunities to forge ahead. It also addresses challenges in areas such as scientific research and infrastructural management.

### *History*

The Mwea irrigation scheme, located at the foothills of Mt. Kenya, is about 100 kilometers to the northeast of Nairobi. Although only 6,000 hectares are under irrigation, the entire scheme covers 12,000 hectares (30,000 acres<sup>3</sup>) and supports a population of over 50,000 organized in approximately 3,242 farm families living in 36 villages. The scheme is the largest rice scheme in Kenya. It is divided into five sections: Tebere and Mwea covering 3,285 and 3,110 acres, respectively, and Thiba, Wamumu and Karaba covering 3,019, 2,880 and 2,650 acres, respectively. Mwea and Tebere are the oldest and the largest while Karaba, located at the lowest end of the scheme, was the last to be developed in 1973. The scheme gets its water from two rivers, the Nyamindi and Thiba. Rice is grown as a mono-crop for only one season in a year. It uses the flooded-paddy irrigation method. The main varieties grown are Basmati 217/370, Sindano BW 196 and IR 2793.

The history of Mwea goes back to five decades, first developed in 1953 by the British colonial government. The scheme was developed using captive Mau Mau labor after the declaration of a state of emergency in October 1952 (Njihia 1984, 1, cited in Turner et al. 1997). Soon after independence, the scheme was handed over to the Ministry of Agriculture, which managed it until 1966 when the NIB was formed through an Act of Parliament (chap. 347). Because the Act vested sweeping powers on the NIB, farmers were unhappy as they lacked a say in the management of the scheme. It was this fact that, in part, led to the emergence, soon after independence, of farmers' associations to represent their interests. Unlike other Kenyan farmer associations, such as the Kenya Planters' Cooperative Union (KPCU), the Kenya Creameries Cooperative Union (KCC), etc., the rice-based associations failed to effectively influence the management of the scheme. Because of lack of an enabling environment and internal management problems, these associations were rather unstable for close to 40 years as described below.

The first association, the Mwea Irrigation License Tariff Cooperative Society, was formed in 1964 and later changed its name to Mwea-Tebere Cooperative Savings and Credit Society Limited. In 1967, a sister society was formed under the name, Mwea Farmers' Cooperative Society. The management and membership of these two associations remained the same until 1981 when the two split and each established its own management. In 1983, the two societies joined and a banking section was formed under the name Mwea Amalgamated Rice Growers'

---

<sup>3</sup>1acre=0.4049 hectare and 1 hectare=2.47 acres.

Cooperative Society Limited. In 1993, the giant society split again to form what is currently known as the Mwea Rice Growers' Multipurpose Cooperative Society Limited and the Mwea Rice Growers' SACCO Society Limited. Although the two operate under two different sets of management, they work closely and may soon be amalgamated because they believe that it was the NIB that kept them apart Mwea Rice Growers' Cooperative.

There were quite a number of areas of conflict between the NIB and the farmers. The reasons for these were low producer prices, high cost of irrigation-related services, such as seeds, fertilizers and chemicals, a land tenure system that treated farmers as tenants and the absence of the voice of the farmers within the management. After a heightening of confrontations between the NIB and the farmers, the latter took over the running of the scheme in 1998. This study traces the historical events fomenting the radical changes and analyzes the current management system, and its challenges and opportunities to forge ahead.

### ***Study Objectives***

The overall objective of this study was to document the management change that had occurred in the Mwea irrigation scheme, moving from government management to producer management. The study further explored potential implications of this change for continued productivity of the scheme.

## **Study Methodology**

### ***The Process and Content***

The study methodology was both participatory and consultative. The choice of this approach was based on the conviction that local people and relevant stakeholders knew best about their own situation, needs, priorities and opportunities. The study specifically traced the history of the scheme, management under the NIB, the relationship between the NIB and the farmers, the factors that triggered the break and the new management.

### ***Stakeholders and Information Sources***

The main sources of information for this study included:

- a. Existing literature on the scheme (surveys, reports, media)
- b. Key stakeholders:
  - the NIB management and the field managers
  - the Central Committee of the MRGM and the technical staff
  - rice farmers from three sections, Mwea, Karaba and Thiba, including women, men and young people, particularly young men
  - rice millers: male and female
  - rice merchants

The selection criteria for the sections to be consulted within the scheme took into account diversity and unique differences within the irrigation scheme. The age of the scheme and access to irrigation-related services, such as water, were key considerations. It was on this basis that Mwea, Thiba and Karaba were selected. Both Mwea and Thiba are well watered while Mwea is one of the oldest sections. Karaba is the most disadvantaged in terms of access to irrigation water but it was the last to be established.

Within the sections, discussions were held with mixed groups of men, women and young men. This was contrary to the original design that envisaged separate group discussions with men, women and young people. The rice farmers rejected this format because all information relating to this change was public information, and all individuals, irrespective of age and gender had a voice in this matter. Perhaps not so explicitly stated was the fact that they were suspicious of outsiders and the suggestion of working with different groups was seen as “divisive.” To the satisfaction of everybody, the suggested system worked out well.

Institutional-level consultations were held with the management teams within stakeholder organizations. The stakeholders included the Mwea Rice Multipurpose Cooperative Society, the Mwea Irrigation Agricultural Development and the Mwea Irrigation Scheme and the rice mill.

Each of the above sources provided information on the history of the scheme, the management, the relationship between the NIB and the farmers, areas of conflict, management by the rice producers, challenges faced by the new organization and the way forward.

## **Management of the Mwea Irrigation Scheme by NIB**

### ***The Irrigation Act and Regulations***

The NIB, established in 1967 through an Act of Parliament, chapter 347 of Laws of Kenya (GoK 1967), managed the Mwea Irrigation Settlement Scheme up to the end of 1998 when the rice farmers took over its management. During the previous three decades, the NIB had used powers vested on it by the Act guided by regulations developed in 1977 (GoK 1977). Through the Act, the NIB was supposed to do the following:

- Conduct research and investigate into the establishment of national irrigation schemes.
- In conjunction with the Water Resources Authority, established under the Water Act, formulate, and be responsible for, the execution of policy in relation to national irrigation schemes.
- In consultation with the pro-tem Minister of Finance, raise funds for the development of national irrigation schemes.
- Coordinate and plan settlement on irrigation schemes.
- Design, construct, supervise and administer national irrigation schemes.

- Determine the number of settlers to be accommodated in a national irrigation scheme.
- Provide land in national irrigation schemes for public purposes.
- Promote marketing of crops and produce grown or produced on national irrigation schemes and liaise with organizations responsible for the marketing of agricultural produce.
- Provide, either by itself or by agreement with other persons, for processing of agricultural produce grown or produced in national irrigation schemes.
- Award scholarships or bursaries for the study of irrigation (in Kenya and elsewhere) or any other subject that the NIB considers to be of benefit to the NIB.

In addition, the NIB was mandated to impose a:

- cess on all or any agricultural produce grown in a national irrigation scheme
- cess on all or any agricultural produce processed in a national irrigation scheme

There was however a condition attached to this cess. *The cess shall only be levied for the purpose of meeting the cost of services provided in the relevant scheme and for which services no other direct charges are available or payable.* The cess levied in Mwea was in some cases used to subsidize other national irrigation schemes in the country, mainly Ahero and Perkerra. This transfer of rice profits from Mwea to other schemes was among the main sources of conflict that led eventually to the rift between the farmers and the government.

To support the NIB in the implementation of this Act, the Parliament developed regulations now contained in Legal Notice 68<sup>3</sup> of a Kenyan Legislation of 1977. These regulations are legally binding, and almost nonnegotiable. They were needed to help sustain the NIB that, as a parastatal, had to be financially self-sustaining and had to do this through recouping its overhead costs from the farmers. Some examples include the following:

- A licensee shall cultivate his holding to the satisfaction of the manager, and in accordance with the crop rotation laid down by the manager and shall comply with all instructions given by the manager relating to the cultivation and irrigation of his holding.
- As soon as each crop, other than paddy, has been harvested, the licensee shall deliver it, other than such portion as he may wish to retain for his consumption and that of his authorized dependants living with him, to the manager at a collecting station to be appointed by the manager, or shall otherwise dispose of it in accordance with the instructions of the manager.
- A licensee shall comply with all instructions given by the manager with regard to good husbandry, the branding, dipping, inoculating, herding, grazing or watering of stock, the production and use of manure and compost, the preservation of the



fertility of the soil, prevention of soil erosion, the planting, felling, stumping and clearing of trees and vegetation and the production of silage and hay.

- A licensee shall not hire, cause to be hired, or employ stock or machinery for cultural operations, other than stock and machinery owned by the manager, without prior written approval of the manager.
- The manager may allocate to a licensee a house to be occupied by him within the scheme or may permit a licensee to erect his own house.
- Any licensee who fails to comply with these regulations shall be guilty of an offence and could be liable to have his license terminated by the Minister on the recommendation of the manager (after confirmation by the committee) and the Minister's decision will be final.

To enforce these rules, the NIB has put in place the necessary structures. For example, it maintained guards at strategic points within the scheme to screen the farmers to ensure that no rice was smuggled out of the scheme (farmers were officially allowed 12 bags of 75 kg per year for home consumption). These rules and regulations generated resentment and hostility between the NIB and the farmers.

### ***NIB Membership and Exclusion of Farmers***

The Irrigation Act treated farmers as passive recipients of strict instructions from the NIB. This is clearly reflected in the membership of the NIB that completely marginalized the real rice farmers as reflected below:

- The Director of Agriculture.
- One representative from each province in which a national irrigation scheme exists, appointed by the Minister and names suggested by the Provincial Agricultural Board.
- The Director of Water Development.
- Chairman of Water Resources Authority.
- Permanent Secretary to the Ministry of Finance.
- Permanent Secretary, Treasury.
- Permanent Secretary, Economic Planning.
- No more than three persons, appointed by the Minister who, in his opinion, have qualities of benefit to the NIB.

In practice, the NIB managed the scheme as reflected in its absolute role in the following:

- flooding the paddy fields

- rotavation (land preparation) of the fields using MIS tractors
- provision of seeds
- supervision of production of seeds by selected farmers
- provision of fertilizers and determining the amount and timing of application
- direct application of chemicals on the crop
- clearing of canals
- collection of rice after harvest and milling it
- marketing of the crop and determining the price and the dues for the farmers

The management of the scheme by the NIB was considered harsh by the farmers on account of the following reasons among others:

- *Confiscation of land from the “tenants.”* Once taken away, the land is said to have been corruptly given out to people external to the scheme.
- *Harassment of farmers.* Farmers reported various forms of harassment from the NIB. For example, farmers were required to spend 12 hours on their farms; for failure to do so, penalties were meted. After harvest, the NIB could take more than 10 days before collecting the paddy. During this period, the farmers would spend nights out providing security to the paddy. Any attempts by the farmers to retain more rice than was allowed by the NIB were harshly dealt with. There was the case of this female farmer who is said to have “hidden” 4 kilograms of paddy. Although she had a young baby, she is said to have spent days between police cells and the courts. The guards who undertook the unpleasant task of screening gum boots and thermos flasks for hidden paddy are said to have been, not just hostile, but also corrupt.
- *Total disregard and disrespect from the field managers.* The farmers described occasions when they would go to the NIB offices for official purposes but would be turned away in ways that were humiliating and embarrassing.
- *The services provided by the NIB.* These are said to have been unduly expensive and on many occasions inefficient. Information gleaned from NIB reports indicate that just about half the value of the rice crop went into the payment of these services. This is well illustrated in a 1995 socioeconomic survey<sup>4</sup> carried out by NIB and JICA. The results of the survey indicated that, an average farmer obtained a total yield of 83.5 bags per 4-acre plot. Of these, 10.5 bags were consumed by the family and the remaining 73 sold to the NIB. From the expected income of KSh

---

<sup>4</sup>Tsuruuchi and Waiyaki 1995.

75,150, the farmer finally received KSh 39,921 after deductions of KSh 31,420 (cost of materials) and KSh 8,501 for wage of hired labor.

The management of the scheme by NIB was considered not transparent. According to the farmers, it was not clear how deductions were determined, a situation that created suspicion between the parties.

### ***The Scheme and the Socioeconomic Situation of the Rice Producers***

The socioeconomic situation of the Mwea farmers did not improve during the entire period when the NIB managed the scheme. This is what the farmers said, was observed and also confirmed from a 1995 NIB/JICA socioeconomic survey that revealed that farmers never managed to meet their basic household needs from the rice proceeds.

### ***The NIB and the Scheme: Current Position***

The study team held discussions with NIB field managers on a variety of issues. At the time of the survey, there was little activity within the field-level organs of the NIB. These include MIS, the MIAD and the rice mill. This was, however, not unexpected since the farmers had assumed many of the roles previously held by the NIB. A meeting with the rice mill manager on 30 August 2000 confirmed the changed circumstances of the NIB in Mwea. He referred to the rice-mill-related activities as being dead at the time. Of the 120 workers 75 percent were being sent home on unpaid leave until further notice. Before the change, the rice mill had these 120 regular staff and a similar number of casual workers.

Discussing the history of Mwea and the events that had led to the takeover of the management of the scheme, the managers acknowledged the undemocratic mode of management that, although perhaps viewed as necessary at the beginning, failed to change with the times. A senior manager did however indicate that discussions on possible changes had been on within the NIB for quite sometime. For example, the NIB had considered, as early as the 1980s, a review of the Act to increase the role of the farmers in the management of the scheme. In support of this process, workshops had been held with stakeholders but no concrete actions had been taken.

The issue of assets, particularly the rice mill with a capacity of 15 tons per hour (4,000 bags per day) is still a thorny issue between the two groups.<sup>5</sup> The rice mill was registered in 1967 as a private company. Currently, NIB holds 55 percent of the shares against 45 percent owned by the farmers. At this point in time, the farmer association is attempting to gain control of the rice mill. Their argument goes as follows. The NIB has managed this mill since 1967 and it is time to hand it over to the farmers. The farmers also argue that the NIB has not paid out dividends to them for a long time, thus making their cases stronger (the NIB admits that payment of dividends has not been regular). There is a clear stalemate on this issue since the NIB has no plans to just hand over this rice mill to the farmers. The NIB sees the following as the minimum conditions to be satisfied by the farmer group for the mill to be transferred:

---

<sup>5</sup>The farmer group, currently using many small-capacity privately owned mills, is in dire need of a large mill with sorting and grading capacity. High-quality rice has a high market value.

- That the farmers pay off the 55 percent government shares.<sup>6</sup> This is equivalent to KSh 500 million (\$6.25 million). According to the NIB, the failure of the farmers to deliver the 1998 rice crop has resulted in a debt of KSh 300 million (\$3.75 million). The NIB would therefore expect a total of KSh 800 million (\$10 million) from the farmers.
- Alternatively, both the government and the farmers work out a framework that will allow the farmers to use the mill at commercial rates. The profits will then be proportionately shared between the NIB and the farmers

In all these discussions, the managers gave no indication that the NIB was about to leave the scheme to the farmers. In fact, they saw as their core responsibility, continued provision of technical support in critical areas such as research, provision of certified seeds and water management and distribution, among others. These are areas they consider too specialized for the farmers to adequately manage. This is corroborated by the fact that the Ministry of Agriculture, according to the Daily Nation, 14 August 2000, was in the process of constituting a new NIB. This move was however suspended by a court of law because of a pending case filed by the farmers against the NIB and the Minister of Agriculture.

## **Issues of Conflict between the NIB and the Farmers**

As indicated elsewhere, the relationship between the NIB and the farmers had a rough start and never really warmed up. The following are examples of areas of contention arising from NIB regulations governing rice production at Mwea.

### ***Land Tenure and Land Pressure***

Forty years since the settlement in Mwea, farmers are still tenants. The farmers argue against this status on two grounds. One, the farmers have been in the scheme long enough to graduate from tenants to landowners and two, this land was never government land. According to the early settlers, this land originally belonged to the nine clans of the Agikuyu people who live on the foothills of Mt. Kenya. The farmers therefore consider the move by the government illegal and with no basis. The lack of individual land title deeds for farmers' plots has been among the most contentious issues in Mwea and was, to a large extent, the reason for some of the more violent riots between 1996 and 2000.

This whole issue was described in a media article<sup>7</sup> in which the farmers sent an open letter to the Attorney General over what they perceived as the inhuman Irrigation Act. The farmers have strong views on the land issue; under the Act, the farmers remain settlers and have no estate under the Law of Succession Act through which their dependants can inherit (The People, Sunday, 24, September 2000). Past suggestions by the government to renew the current Land Leases in place of Title Deeds have met with resistance.

---

<sup>6</sup>Because of difficulties in the relationship, joint ownership of the mill, with farmers owning more shares than the government, has not been considered.

Another land-related complaint was the practice of unilateral withdrawal of land leases by the NIB. The NIB withdrew such leases on the grounds of poor management of the land by the licensee. Such land was quickly given out to other people, not necessarily from Mwea. The farmers view such transfers with hostility. These actions were, however, covered by the Act and the Regulations and there was little the farmers could have done in the circumstances. In further discussions with the farmers on the matter of suboptimal husbandry, the farmers accepted that there were a few cases of this nature, but they explained that proceeds from rice were never enough to sustain families and farmers needed to engage in other activities to fill this gap.

Although against the regulations, the growing pressure on the land has forced farmers to open up new land bordering the Mwea scheme for rice production, and using the water system servicing the current scheme. The land pressure is explained by the fact that the four acres allocated to families at Mwea were at the time of inception of the scheme adequate because the families were small. The situation has however changed considerably over a span of 40 years. The family sizes have more than trebled, thus, overstretching the farm sizes. It is against this background that the farmers have established new rice fields, popularly known as *jua kali*. This name literally means “hot sun” and applies to local informal industries in which many Kenyans engage. What the farmers have done is illegal according to the regulations of the scheme. Expanding rice production is motivated by the high demand of rice in Kenya (Kenya is a net importer of rice).

As regards the above, it is worth noting that, Mwea, like much of the central province has, since the advent of multiparty politics, identified itself more with the opposition than with the ruling party. Opposition members of parliament have, therefore, supported farmers fully and used this opportunity to discredit the government.

### ***Small, Poor and High-Priced Housing***

According to the regulations, no farmers were allowed to build their own houses without prior authority of the NIB. The regulation was very explicit on this matter; farmers were prohibited from constructing buildings or other works of any kind on the holding or elsewhere in the scheme without prior written consent. Therefore, the NIB assumed the responsibility for providing housing. The farmers have been unhappy on the scheme because the houses are too small and are of poor quality in addition to being overpriced. The houses have mud walls and tin roofs. On size, the NIB perhaps did not anticipate such an increase in family sizes since sons who reached 18 years were supposed to leave the scheme. The cost of each of these houses comes to KSh 12, 972 (\$160). This money was paid to the NIB by farmers in installments of KSh 432.40 per year for a period of 30 years.

### ***Water Use Restricted to Rice Production***

Irrigation water was restricted to rice production during the NIB regime even though rice is not a high-valued crop when compared to horticultural crops, such as tomato. The manager of the scheme had powers to destroy other crops if grown with water from the scheme. The regulation stated that the manager shall have the power to order the destruction of any crops planted in contravention of his instructions or of the provisions of these regulations. All costs incurred during the destruction would be recovered from the rice delivered by the respective farmer. In the latest petition to the Attorney General for repeal of the Act, this issue is highlighted.

The complaint is that the farmers are chained and tied up to rice farming all their lives as they devote their full personal time and attention in the cultivation of the crop ordered by the NIB.

Yet the manager of NIB at Mwea was well aware that horticultural production was taking place upstream of Mwea and was, in fact, collecting fees from those farmers who were pumping water from the NIB canals. Also, on a pilot-trial basis, the NIB had introduced a second crop of soybean, grown in the off-season and at one point it had expanded this program to 500 acres.

### ***Farmers' Lack of Control over Their Product—Rice***

According to the regulation, families could only retain 12 bags of 75 kg of unprocessed paddy after harvest. This amount was expected to feed the family for a whole year. To ensure that the regulation was adhered to, the NIB engaged guards to screen the farmers as they left the fields. Contravention of this regulation saw many farmers in police cells. One woman from the Mwea section graphically narrated her ordeal in police cells for allegedly “smuggling” 4 kilograms of rice. As an illustration of farmers’ desperation, it can be stated that they smuggled rice for home consumption in gum boots and tea flasks on their way home from the farms.

### ***Regulation against Livestock Rearing***

Rearing of livestock in the rice scheme was prohibited. The regulation on this stated that a licensee shall not keep on his holding any stock other than those specified in his license; otherwise, the manager had authority to confiscate and sell such additional stock. This regulation was however not very aggressively pursued and herds of cattle and other small stock are a common sight in the area. This was also confirmed by a study carried out by Tsuruuchi and Waiyaki (1995), which established that more than half of the farmers kept cows, goats and chicken.

### ***Undermining the Family Unit—Boys over 18 to Leave the Scheme***

Although this regulation was never implemented, the farmers are still very incensed by the inclusion of this clause in the Act. They saw it as a way of undermining the culture and the family unit. In their culture, men are supposed to give their sons land and animals to help them start off their own families. Traditionally, these sons would inherit the family assets. This is however threatened by the current “tenant” status, which is not recognized by the Succession Act.

### ***Low Prices and Subsequent Poverty***

At the time of the radical takeover of the management of the scheme by the farmers, the price paid out to farmers for paddy stood at KSh 17.50 per kilogram. In 1998 (at the height of the conflict), the farmers had demanded an increase to KSh 20.00 per kilogram. Even as the NIB declined, there was one thing that the farmers knew. Their rice was worth more than what they were requesting and the real problem lay in paying the cost of a bloated NIB and subsidizing the running of two other national irrigation schemes, namely, Ahero and the Perkerra.

### ***Farmers' Takeover and the Situation at NIB***

The Mwea Rice Growers' Multipurpose Cooperative Society took over the management of the scheme in 1998 after many years of a strained relationship. This takeover was precipitated by many grievances as indicated above. However, at the core were the low price of rice and what farmers perceived as a high level of insensitivity by the NIB. The farmers reported that they were after an amicable solution to this stalemate. This was however not to be. A meeting held between the Ministry and the farmers in 1998 failed to resolve the issues. This final meeting is said to have been the 28 consultative meetings between the two parties on the subject.

Failure to reach a compromise provided the central province opposition parliamentarians an opportunity to castigate the government on insensitivity to the needs and suffering of the farmers. Acts of defiance that followed the stalemate between the government and the farmers therefore had the full backing of the local Member of Parliament and the central province opposition parties.

Consequent to this deadlock, the farmers refused to deliver the 1998 paddy crop to the collection centers traditionally used for that purpose (each section has a collection center). In addition, the farmers started destroying some of the infrastructure, such as the collection centers. During these scuffles, the police were called in, thus fuelling an already volatile situation. It was during one of these riots that two men from the scheme were shot dead by the police. The media covered these events comprehensively.

One question that lingers on is "why this pitch of 'disobedience' from farmers who had all these years lived with the NIB and the regulations?" To some degree, the environment was conducive. The decade had seen the introduction of multiparty politics and liberalization of many sectors including agriculture. Dissent was tolerated and for once, Kenyans could speak openly without fear of detention and harassment. This too was a period of free information flow and interaction. For example, through the joint GoK/JICA research project in Mwea, farmers were trained on how to experiment with new crops such as soybean. They also acquired skills on pricing systems and alternative market outlets. Those who produced soybean and sold the crop directly to buyers (not through NIB) made KSh 270 per kilogram against KSh 27 per kilogram when sold through the NIB.

Young people, born and bred in Mwea were a major source of change. Unlike the original settlers, the children had gone to school, acquired good education and some even had good jobs. For these young people, it was time for change in Mwea. They had lived in poverty and misery, and they wanted to bring an end to this.

In retrospect, young people tend to view the past as a bad dream. A young man of 23 years from Thiba proudly showed us new houses built by young men from the proceeds of the "jua kali" rice (building of houses and opening new land for rice was illegal during the tenure of the NIB). This young man narrated to us how, in 1998, he mobilized youth groups, personally commandeered an NIB lorry full of paddy and shared it out to Mwea residents. According to him, the days of slavery are over.

## **Management of the Scheme by the Mwea Rice Multipurpose Cooperative Society**

### ***About the Cooperative Society***

The Mwea Rice Multipurpose Cooperative Society is a farmer association currently managing the irrigation scheme with, and on behalf of, the farmers. Its history goes back to 1964 when farmer associations started emerging. The associations had a difficult time holding their own as reflected in successive splits and mergers. Although the farmers we talked to attributed this instability to interference by the NIB and had high hopes of greater stability, there was evidence of other challenges in the form of poor management, accountability, etc.

The first association, registered in 1964, was the Mwea Irrigation License Tariff Cooperative Society. It changed its name to Mwea-Tebere Cooperative Savings and Credit Society Limited. In 1967, a sister society was formed under the name Mwea Farmers' Cooperative Society. The management and membership of these two associations remained the same until 1981 when the two split and each established its own management. In 1983, the two societies amalgamated and a banking section was formed under the name Mwea Amalgamated Rice Growers' Cooperative Society Limited. In 1993, the giant society split again to form what is currently the Mwea Rice Growers' Multipurpose Cooperative Society Limited and the Mwea Rice Growers' SACCO Society Limited. Although the two operate under two different sets of management, they work closely and may soon be amalgamated because they believe that it was the NIB that kept them fighting.

### ***New Management of the Scheme***

The current management of the Mwea Rice Growers' Multipurpose Cooperative Society Limited has been in office 2 two years now. Its objective is to improve the economic, social and political welfare of the farmers. It considers as exemplary its performance during this 2-year period. According to the 1999/2000 Progress Report, the society highlights some of its successes during the 2 years it has been in office. For example, it states that between December and February 1999, the MRGM transported all the paddy from the fields to Mwariko in record time and at minimal cost, and land preparation, which started in March, was completed by August 1999, a feat the NIB never achieved during its lifetime in Mwea.

During this period, the society made efforts to keep afloat amid daunting technical, financial and infrastructural challenges. Its management appears a lot more democratic, the price of rice has moved to KSh 30 per kilogram and farmers have the freedom to sell their rice to the highest bidder (except a minimum of 40 bags that must be delivered to the society to meet the cost of services provided by the society).

### ***Governance***

The management consists of a central committee of nine members democratically elected by the farmers, staff members and unit leaders. These nine members represent the five sections of the scheme, i.e., Tebere, Mwea, Thiba, Wamumu and Karaba. To maintain an odd number of members for voting purposes, each of the four sections is represented by two members while one section is represented by one member (the section with one representative will, in the next round, have two members). The committee has however only one female member.



Reporting to the nine section leaders are 68 unit leaders distributed through the five sections. In terms of numbers, Tebere has 17 unit leaders, Mwea 17, Thiba 12, Wamumu 10 and Karaba 10. Out of these 68 unit leaders only 3 are women.

The unit leader is the frontline worker who links the farmers with both the management committee and the technical teams. They monitor views, needs and constraints for onward transmission to the section leader and finally to the society. As a backup, each section has a technical officer, employed by the society. It is important to note that a few of the technical staff are “defectors” from the NIB who have had years of experience in operating the canal system.

An Agricultural Subcommittee coordinated by the Scheme Manager handles technical issues. This subcommittee consists of Agricultural Officers and Irrigation Engineers.

According to the farmers interviewed, what they see as very different from the time of NIB is transparency in running the society. The farmers see this as central to the survival of the society. To ensure this transparency, farmers have put in place appropriate mechanisms. One such mechanism is a *shadow management committee* in each of the five sections that checks and evaluates the work of the official central committee. To demonstrate how seriously they view this matter, the farmers have, in the last 2 years, dismissed one committee for nonperformance.

On taking over, the society moved fast on relaxation of the regulations applied during the NIB tenure. For example, farmers, after delivering a minimum of 40 bags of paddy to the cooperative to meet the cost of services rendered by the society, can freely sell the rest directly to the millers for quick cash. The many barriers and policing of movement of rice are things of the past. A few farmers have also experimented with two crops a year although the results have not been encouraging. A new weed, similar to the water hyacinth has taken root in some canals within the Mwea section. Members of the technical staff attribute this to double cropping.

### ***Farmers’ Voice within the Society***

The farmers own the society and this is confirmed by the freedom with which they make demands on the technical teams at the society level. They also engage and fire members of the central committee if they fail to meet their own expectations. They are well informed and speak about the society with confidence. For example, they know about their assets such as the 20 tractors acquired by the society, have details on a new rice mill recently acquired and awaiting installation, know the cost of services provided to them by the society and are able to explain the financial difficulties of the society. The fact that the farmers have contributed to the acquisition of these assets confirms that they were not against deductions made by the NIB per se, but were against the lack of transparency in the entire process.

### ***Increased Incomes and Changing Lifestyles***

In 1998, when the Cooperative Society took over the running of the scheme, farmers were being paid KSh 17.50 per kilogram of paddy. Today, they get KSh 30 per kilogram. Other indirect gains are from the reduced cost of services provided by the cooperative. The aggregate result of these processes is increased incomes for the farmers. From discussions held with the farmers in three sections of the scheme (Mwea, Karaba and Wamumu) and with the millers in the Wang’uru town, the farmers have much higher incomes than earlier. This is said to have translated into a number of things. The farmers are now cleaner, better dressed, are able to

send their children to school and have embarked on improving their houses. One man from the Mwea section showed off a suit he had on and which he said was his first since settling in Mwea over three decades ago. He attributed his ability to buy such a suit to the change of management. For the women, they can now buy good clothes and shoes to prevent the cracking of their feet. Young men from the Wamumu section of the scheme who fully participated in the riots, showed us their new houses, which they had never dreamt of for two reasons; one, it was against the NIB regulations to build such houses and two, under NIB they would never have got enough money for such structures.

For the millers, this new change has transformed their livelihoods. In Wang'uru alone, there are more than 100 mills operating either independently or leased by the MRGM. The millers charge KSh 1 per kilogram of paddy milled and also retain the bran from the paddy. This bran is used in the manufacturing of animal feeds and fetches a good price for the millers. The millers admit that life has changed in Mwea and Wang'uru. According to the farmers who were interviewed in late 2000, virtually everybody is now able to generate some income for themselves, an aspect said to have reduced thuggery and insecurity to a minimum. However, by May 2001, there was less optimism in the new management by the MRGM as some farmers had not had their rice deliveries paid for two seasons.

### ***Challenges and Opportunities***

While certain things have worked well, the society knows that there are daunting technical and financial challenges ahead of them. The human capacity is overstretched and they have limited equipment and machinery, and virtually no capital for operations. Banks are also unwilling to advance the MRGM loans in view of uncertainties of the future of the scheme

*Human capacity.* The Cooperative Society has an extremely small workforce. According to one of the technical officers, the current team is a drop in the ocean when compared to the numbers during the NIB tenure. Each irrigation block/section has only one official and none of them has an office.

Certain key functions, such as water management and research, have not been established. The absence of systematic research, which is necessary to ensure regular supply of good seed, threatens the very foundation of the scheme. Plans for water distribution, particularly during water-shortage periods and plans for maintenance to allow equitable water distribution are necessary and need to be prepared by well-qualified staff members.

*Equipment.* During the time of the NIB, the scheme had enough machinery and equipment to handle the operations. After the takeover by the farmers, movable machinery, such as tractors and excavators, were transferred by the NIB to other national schemes. Research equipment is still at MIAD but out of reach of the society. These difficulties notwithstanding, it is encouraging to note what the society has been able to do on its own through the use of nontraditional approaches as discussed below.

### ***Subcontracting Services***

*Tractors.* The society has only 20 tractors of its own. Because these are clearly inadequate to rotavate (prepare the land) the 6,000 hectares, the society has contracted the services of independent contractors. The society pays for the services but deducts the cost from the

farmers' proceeds. In the process of this struggle, the society has learned that it is cheaper and more efficient to farm out this service.

*Rice mills.* At the time of this survey (August 2000), the society had no functional rice mills of its own. For it to mill the rice delivered by the farmers, it leased rice mills from independent contractors. At peak time, it leased over 100 rice mills. This was, however, seen as a temporary measure while awaiting the installation of a 3-ton per hour rice mill it had just acquired. The society also revealed its plans to acquire more if the stalemate over the jointly owned rice mill was not quickly resolved. The society acknowledged that this was one service it was going to manage to maintain the high quality of rice. The current quality of rice is much lower than what the NIB produced. This automatically creates a marketing problem, particularly since imported rice of good quality is freely available at competitive prices in the local market.

### ***Production of Seeds***

This area is highly specialized. During the NIB tenure, a number of farmers were contracted to multiply seed for distribution to the rest of the farmers during the planting season. This ensured an uninterrupted supply of good-quality seed. When the society took over the running of the scheme, it employed the same seed-bulking farmers for the 1999 crop. These farmers opted to deliver their paddy seed to the MRGM due to the higher price offered. Now, however, the farmers are no longer producing seed leading to the nonavailability of good seed and lower-quality rice.

### ***Research***

This emerged as one of the weak areas. The society fully recognized this fact and was making efforts to address the matter. The acquisition of 20 acres, made freely available by farmers for field trials, is a demonstration of this commitment (the facilities at MIAD are however still held by NIB).

### ***Rice Milling***

The society has acquired a small mill with a capacity of 3 tons per hour although the minimum capacity needed is 15 tons per hour. The new mill was in the process of being installed during our interviews. At this time, the society was leasing rice mills from contractors. However, these mills had no capability to grade the rice, thus making it difficult to compete with imported rice in the local market.

### ***Working Capital***

Running the irrigation scheme is an expensive undertaking. The cooperative requires a minimum of KSh 300 million upfront to run the scheme. These funds are needed to meet the cost of fertilizer (KSh 70 million), land preparation (KSh 30 million), pest control and gunny bags (KSh 20 million) and payment to farmers close to KSh 150 million. In many ways, the new management is providing the services using a model close to that used by the NIB. What distinguishes it from the NIB management is its degree of transparency and the role of the farmers in the management of the operations.

The efforts by the society to get credit from commercial banks have not been successful and the society attributes this to interference by the government. They quote situations where

negotiations were almost concluded only to learn at the last moment that the deals had been terminated. In the midst of these financial difficulties, the society also has found some workable solutions. In 1999, it identified a rice buyer who paid KSh 200 million upfront, thus assisting the society to meet some of its financial needs.

### ***Human Health***

Malaria and intestinal schistosomiasis (bilharzia) (see paper by Mutero on health impact assessment) are common in the Mwea irrigation scheme. The NIB used to have a surveillance team to monitor and ensure that the two diseases did not attain epidemic proportions. This was partly achieved through the treatment of irrigation canals with molluscicides to kill carrier snails of bilharzia, and the provision of health credit facilities. Currently, there is no organized treatment of canals with anti-snail chemicals. Transmission of bilharzias might, therefore, rise again to the high levels common before the NIB instituted regular control measures.

### **Discussions**

A change has occurred at the Mwea irrigation scheme. The NIB at Mwea is currently almost nonfunctional despite the capacity it commands in terms of technical expertise, facilities and political support. However, all signs indicate that the NIB has no plans to leave the scheme. For example, the Ministry is in the process of reconstituting a new NIB, but due to a pending suit between the Ministry and the farmers' cooperative the court has temporarily halted this. Alongside the NIB is the farmer association, determined to make it despite many odds. The challenges are real. At the society level, the technical, financial and infrastructural challenges are daunting. There is a dire need for operating capital and the canals are in need of excavation, yet there is no equipment while a large-capacity rice mill is needed to produce quality rice.

This analysis clearly underlines the unfinished business at Mwea. There are issues to be resolved between the government and the farmers but, as it happens, the farmer cooperative urgently needs injection of capital to successfully keep the scheme functional.

### **Conclusions and Recommendations**

#### ***Conclusion***

After close to 40 years of a highly structured top-down management, radical changes have occurred at the Mwea rice irrigation scheme. The farmers took over the running of the scheme at the end of 1998 and have been running it since, albeit with difficulties. The management of the scheme is now by the Mwea Rice Growers' Multipurpose Cooperative Society Limited through an elected management system. The Savings and Credit Cooperative (SACCO) has been integrated into the management and is currently responsible for sale of rice and payment of farmers' dues. This new role was decided on by farmers when the MRGM had difficulties in timely payment of farmers' dues.

There are divided assessments on the nature of this change. According to the farmers, this change is final and there is no going back. The use of the term "divorce" to illustrate this change is enough to conclude the position of the farmers. The government, while

acknowledging this change, still sees its role in the scheme and considers itself the de jure manager. In some ways, the government is right since it still controls assets essential to the operations of the scheme, e.g., the rice mill, the research facilities at MIAD and the paddy collection centers but, in fact, literally the keys to the main control structures of the system were handed over to the farmers' group. A central issue is the Irrigation Act. This Act and the status of landownership are central to the meaningful takeover by the farmers and the government is aware that the farmers cannot change the Act on their own. The fact that the Ministry of Agriculture is in the process of reconstituting a new NIB for the scheme reinforces this position. Therefore, it is clear that while the farmers are functionally in charge of the scheme, the government still has a strong hold on the critical elements of the scheme.

Despite the challenges faced by the MRGM, some substantial positive changes have taken place. The management system is apparently more democratic and sensitive to the plight of farmers; prices paid to farmers have almost doubled; and opportunities for farmers and the people of Mwea have increased (farmers can sell the bulk of their paddy to independent rice millers, thus creating a new category of beneficiaries within the scheme). In addition, farmers have opened up new land for rice on their own initiative. The farmers interviewed have reported that, on the whole, the socioeconomic status of the entire area has improved.

While performance in certain areas is commendable, the cooperative society also faces some major challenges. Its technical team is inadequate, it badly needs operational capital and facilities for research and seed multiplication for research, it has limited milling capacity and it lacks critical machinery and equipment, such as excavators meant to keep the canals free of weed and silt. Innovation and flexibility have, however, helped the society in the face of these constraints. For example, the society has leased small rice mills from independent contractors and has contracted out services, such as rotavation, to supplement its 20-tractor capacity.

The split between the NIB and the farmers is far from complete and there is clearly unfinished business between the two parties. The farmers are still pressuring the Attorney General to review the Irrigation Act and there is the unresolved issue of the jointly owned rice mill and the idle infrastructure at the scheme (paddy collection centers, the MIAD research capacity). The society sees a clear link between this stalemate and its inability to get loans from banks. In the society's view, the government is interfering with its operations.

In conclusion, it is apparent that dialogue and consultation between the government and the farmers are urgently required.

### ***Recommendations***

- Both the MRGM and the Ministry of Agriculture need to initiate meaningful dialogue to resolve pending issues, such as the review of the Irrigation Act. At the functional level, matters relating to joint assets, such as the rice mill and the paddy collection centers, among others, should be resolved.
- Review and appropriately strengthen the current capacity of the farmer cooperative society. While this should be preceded by a clear analysis of core functions and capacity requirements, visible gaps include equipment and machinery, operational capital and staffing.

- The society needs to develop a strong operational system to improve the efficiency of the farmer cooperative. The society has embarked on certain aspects of this, such as computerization, but more needs to be done.
- Strengthen the already initiated democratic process to ensure effective farmer representation and equity in terms of gender and other social characteristics.

## **Researchable Areas**

### ***Technical***

A new weed that resembles the water hyacinth has taken root in some water canals in Thiba. Although not currently a threat, as a preventive measure, it is important to establish its nature and implications.

### ***Socioeconomic Changes***

Establish the level of socioeconomic change and subsequent changes at the household level. This will be in response to reports from farmers, rice merchants and millers that there has been an increase in disposable income for most people in the scheme.

### ***Organizational Systems***

Establish effective management systems within the society. Such systems should include computerization of their operations (the society is in the process of doing this), management capacity of the Central Management Committee and training needs of the technical staff, among others.

Research in this area should document the current systems and the basic minimum requirement to assist the society to embark on relevant developments.

## **Acknowledgements**

The authors of this study acknowledge inputs and support from different individuals and groups. A number of groups are here identified for special mention. They include the rice farmers of Mwea, Thiba and Karaba, who without inhibition, narrated the story of the Mwea rice scheme and changes that have taken place during the last 40 years. The team also received support from the Management Committee of the Mwea Rice Growers' Multipurpose Cooperative Society and the Mwea Irrigation Settlement Scheme team in the field. Both groups provided us with details on the history of the scheme and on the technical and operational sectors. A very relevant source of information comprised individual rice millers who took us round their mills and explained to us the changed environment and what it meant to the people of Mwea.

This study was funded by the International Water Management Institute.

## Literature Cited

- Bandaragoda, D. J. 1999. *Institutional change and shared management of water resources in large-scale canal systems: Results of an action research program in Pakistan*. Colombo, Sri Lanka: International Institute for Water Management.
- Bakker, M.; R. Barker; R. Meinzen-Dick; and F. Konradsen. 1999. Multiple uses of water in irrigated areas: A case study from Sri Lanka. International Food Policy Institute and International Water Institute.
- The Daily Nation. 2000. (14 October)
- GoK (Government of Kenya). 1967. *Irrigation Act, Chapter, 347 of the Laws of Kenya*. Revised Edition. Kenya.
- GoK. 1977. *The Irrigation (National Irrigation Schemes) Regulations, 1977. Legal Notice No. 68 on Irrigation Act, Chapter 347. Subsidiary Legislation*. Kenya.
- Muchai, E. 2000. Grapes of wrath. The executive.
- Tsuruuchi, T.; and N. Waiyaki. 1995. Report on farm economic survey inside and outside M.I.S.
- Turner, T.E.; W. Kaara; and L. S. Brownhill. 1997. Social reconstruction in rural Africa: A gendered class analysis of women's resistance to cash crop production in Kenya.
- Wangui, K. 2000. *Mwea rice farmers petition Wako: Irrigation Act repressive*. The People Daily. Kenya.

# Health Impact Assessment of Increased Irrigation in the Tana River Basin, Kenya

Clifford M. Mutero<sup>1</sup>

## Summary of Health Impacts

### I. Upper Tana

Health Hazard	Community Risk Factors	Environmental Risk Factors	Institutional Risk Factors	Health Risk Associated with Increased Irrigation
Malaria	Important cause of morbidity among communities. Immune status low due to seasonal transmission.	Increase in potential mosquito breeding habitats expected with increase in irrigated agriculture. Increase in seasonal colonization of the breeding sites by mosquitoes. <i>Anopheles arabiensis</i> is the main vector of malaria and exploits varied habitats ranging in size from cattle hoof prints to rice fields.	Hospital facilities congested or difficult to access. No regular surveillance for malaria or its mosquito vectors. MOH and NGO-supported programs for insecticide-treated nets in some communities.	Increased malaria risk due to irrigation.
Schistosomiasis	Exposure to parasites expected along edges of micro-dams or shallow wells among children having a swim and women doing laundry and fetching water.	Vector snails expected to rapidly colonize micro-dams including areas frequented for domestic purposes.	Curative. No surveillance and vector control at present.	Increased risk of infection with <i>S. mansoni</i> .
Human nutrition	An increase in farmers producing vegetables and fruits.	Local diet will improve if there is irrigated agriculture.	There will be a reduction in delivery of relief food by either the government or the NGOs.	Improved nutrition for Upper Tana communities.
Other hazards	Awareness of pesticides poor among communities.	Increased exposure to pesticides used in production of high-value crops.	Community health education programs inadequate.	Increased risk in agrochemical poisoning.

<sup>1</sup>International Centre of Insect Physiology and Ecology (ICIPE), P.O. Box 30772, Nairobi, Kenya or c/o ICRAF, P.O. Box 30677, Nairobi, Kenya. Currently, the author is the IWMI Regional Representative for eastern Africa and Coordinator, CGIAR Systemwide Initiative on Malaria and Agriculture (SIMA).



## II. Lower Tana

Health Hazard	Community Risk Factors	Environmental Risk Factors	Institutional Risk Factors	Health Risk Associated with Increased Irrigation
Malaria	Leading cause of morbidity among communities in the Lower Tana area.	Increase in mosquito-breeding habitats expected in case of expanded irrigation. <i>Anopheles arabiensis</i> is an important vector of malaria along the Lower Tana area.	Hospital facilities congested or difficult to access. No regular surveillance for malaria or its mosquito vectors. MOH and NGO-supported programs for insecticide-treated nets in some communities.	Increased malaria risk.
Schistosomiasis	Exposure to parasites expected in the increasing number of smallholder irrigation schemes.	Populations of vector snails expected to increase with increase in smallholder irrigation.	Curative. No surveillance and vector control at present. Management of two downstream irrigation schemes has collapsed.	Increased risk of infection with <i>S. haematobium</i> in the Lower Tana area.
Human nutrition	An increase in the number of smallholder farmers expected in the Lower Tana area.	Food production will improve under renewed irrigation activities.	There will be a reduction in the requirement for delivery of relief food by either the government or the NGOs.	Improved nutrition for the Lower Tana area communities in case of enhanced irrigation.
Other hazards	Poverty and illiteracy generally high among downstream communities.	Exposure to pesticides and other agrochemicals used in upstream crop production systems.	Hospital facilities congested or difficult to access.	Increased risk in chronic and acute agrochemical poisoning.

## Introduction

Agricultural policies, products and processes are major determinants of people's health. More than two-thirds of the people in developing countries derive their livelihood from agriculture. Most working time is spent in agriculture, and most income on food. The health of most people is integrally linked with the agriculture sector, and agriculture dominates life in the rural areas (WHO 1986).

Agriculture involves transforming inputs, e.g., soils, solar radiation, rain, irrigation water, labor, agrochemicals and seeds through technologies and structures of work, into foods and other outputs. While agricultural policy makers may collaborate readily in the elimination of known, existing and clearly visible health risks that can slow agricultural growth, equal effort is often not directed at uncovering health risks implicit in existing and planned agricultural processes, which often negate the efforts of health and have negative feedback effects on agriculture.

Health and agricultural sectors need to work together to reinforce and support each other's goals. At the local level, the two sectors should address themselves to the impact that agricultural processes have on the health of vulnerable groups in particular and the farming population as a whole. Both health and agriculture should concentrate on the equity-oriented components in agriculture. These tasks should be complemented by a clear definition of the contribution of the health sector to agriculture and of agriculture to the health sector.

In Kenya and many other African countries, only a small fraction of the irrigation potential has been developed (see Ngigi's first paper). A considerable part of the area under irrigation is for rice production. The demand for rice on the continent is growing rapidly and the total area under its cultivation is likely to increase. Unfortunately, the flooding of agricultural land during rice cultivation has often resulted in increased health risks due to malaria and other vector and water-borne diseases (Lacey and Lacey 1990). In Kenya, research in an irrigated area has, for instance, shown a 70-fold increase in the number of malaria vectors biting people, compared to nearby nonirrigated areas (Surtees 1970). Species succession and peaks in vector densities related to the rice cultivation cycle are well-described phenomena.

## Objective

This report presents a prospective health impact assessment (HIA) of increased smallholder irrigation in Kenya. The purpose of the assessment is to identify opportunities for improvement of human health and enhancement of household incomes through better agro-ecosystem management. Thus, an HIA provides the means by which inter-sectoral collaboration can be facilitated for the incorporation of health safeguards and mitigation of health impacts for water resources projects and other types of development (Bolton et al.1990; Birley 1995).

## Methodology

The approach used in the present HIA was mainly qualitative, using secondary information from both published reports and key informants. A social-environmental model of health was used where the health, environmental and social impacts were interlinked. In this regard, reports and other materials compiled during the previous environmental assessment (EA) projects of the Tana river were found to be particularly useful in the absence of site visits. The latter were not feasible within the limited duration of the HIA, more so in view of a general lack of security in most of the study area.

The procedure for HIA consisted of the following four main steps (Birley 1995; Birley et al. 1997):

- *Identification of stakeholder communities.* Stakeholder communities refer to the different populations in the project area, mainly grouped according to their occupation, geographic location or ethnicity in the present HIA.
- *Identification of health hazards.* According to the HIA procedure, a health hazard is a potential source of harm. Health hazards can be conveniently discussed under

the following five categories: communicable diseases; noncommunicable diseases; malnutrition; injury; and psychosocial disorders.

- *Health risk assessment.* Health risk is a measure of the likelihood of a potential hazard affecting a particular group of people at a particular time and place. For the present project, assessment was limited to an indication as to whether there would be an increase or decrease of health risks if there was a substantial increase in smallholder irrigation along the Tana river basin. Health risks associated with increased irrigation were assessed on the basis of the following considerations: population risk factors; environmental risk factors and institutional risk factors.
- *Recommendations for risk management and mitigation measures.* Safeguards and mitigating measures can reduce the negative health impacts and optimize health opportunities if planned for in advance or incorporated in the project design. They include environmental management measures and the provision of certain basic health services.

## Stakeholder Communities

### *Indigenous Rural Populations*

For purposes of the HIA, the stakeholder communities in the proposed project area were arbitrarily grouped into Upper Tana and Lower Tana areas on the basis of geographic location. The site for the proposed Grand Falls/Mutonga Hydro Power Project (figures 1 to 3) represented the dividing line between the Upper and Lower Tana areas. The Upper Tana area crosses three districts: Embu, Tharaka Nithi and Mwingi. The population comprises several ethnic groups, including Embu, Meru, Mbeere, Tharaka and Kamba (Ominde 1974). Communities in the Upper Tana area practice mixed farming. The staple food crops include maize and millet and the most common cash crops are cotton, millet and green gram. Livestock forms an important component of the farming systems.

The larger part of the Lower Tana administratively falls under the Tana river and Garissa districts, with the Tana river itself acting as the boundary between the two. Major groups of people in the area include the Somali, Boran, Pokomo and Orma. The Tana river district is mainly occupied by the largely Orma pastoralists and Pokomo recession farmers while the rural population of Garissa is almost entirely Somali pastoralists. According to the previous EA report (Acropolis 1995), both arable and pastoral farming systems have evolved to make use of, and depend on, the natural flooding pattern of the river. Among the main economic activities, the Pokomo practice flood-recession farming for their staple crops while the Orma have evolved a transhumance system that links dry-season grazing in the floodplains with wet-season grazing in the hinterland. Despite being nomadic, the Somali pastoralist system depends on the river for stock water for up to 6 months of the year.

In the past, a number of irrigation schemes have been established on the Tana river. Two of the previous projects, Bura and Hola irrigation schemes were large scale but both collapsed for different reasons (JICA and Nippon Koei 1995). In the case of Hola, the Tana river changed its course in 1989, leaving the main inlet at Laini pumping station dry. The

Figure 1. Health facilities generally available in the Upper Tana and Lower Tana areas.



Figure 2. Endemicity of malaria in Kenya (after MOH 1998).

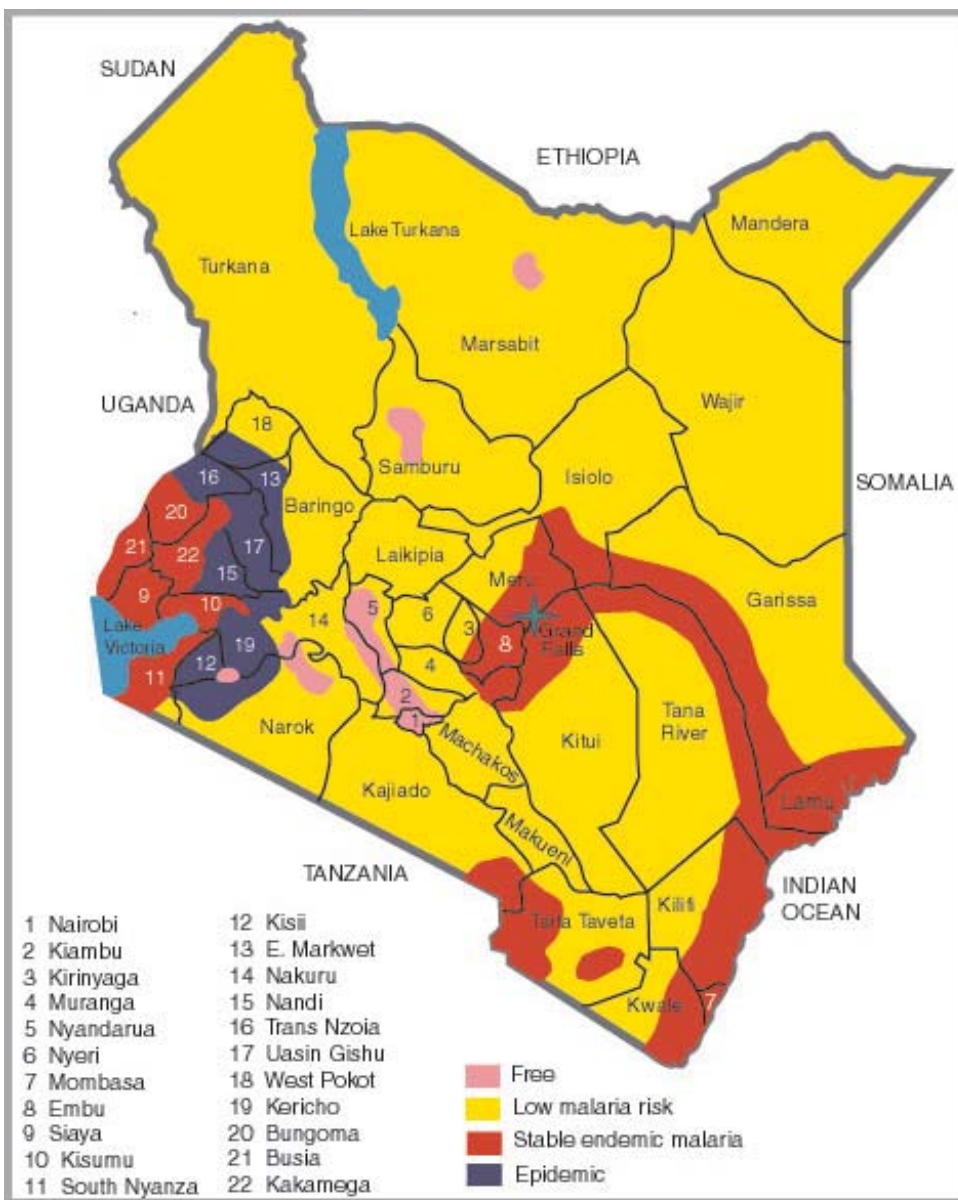
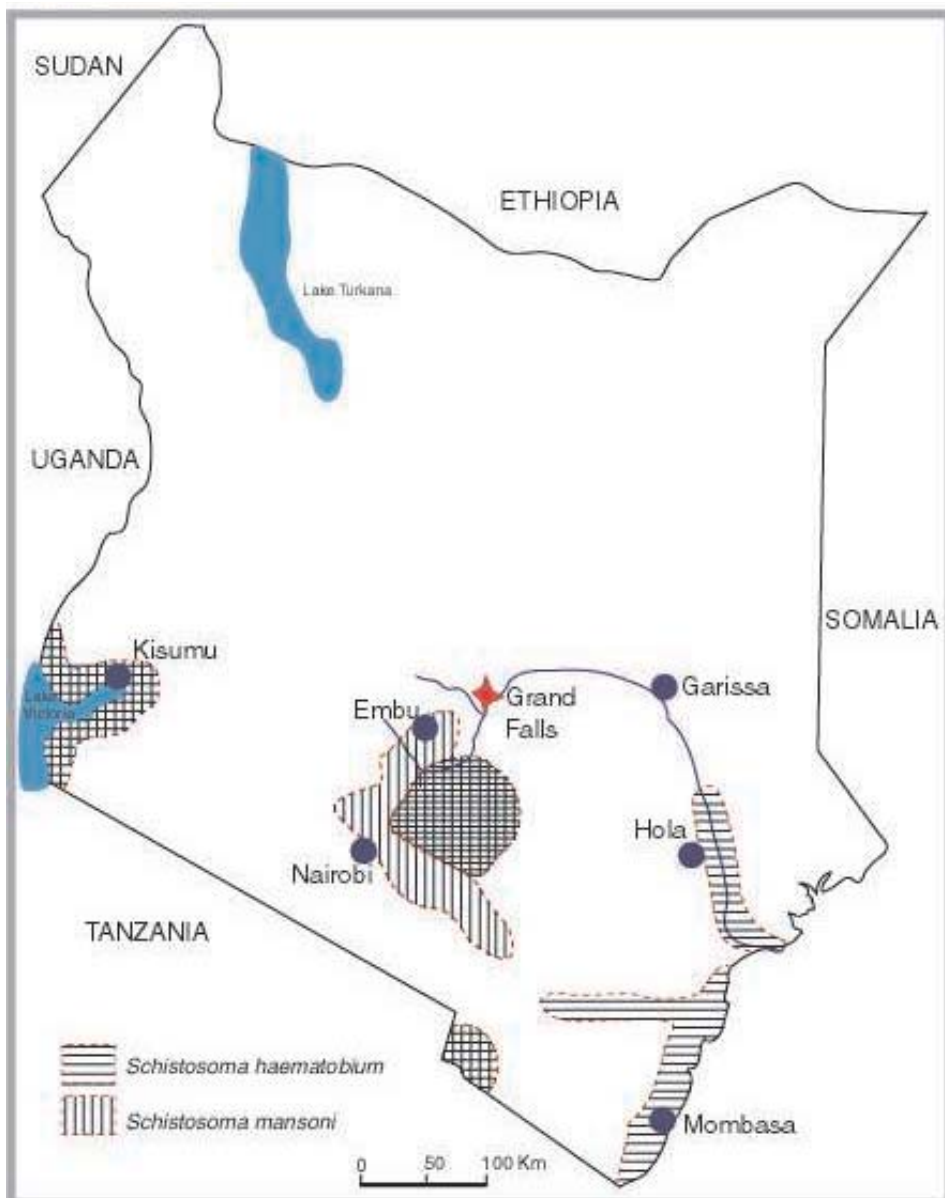

Figure 3. Prevalence of schistosomiasis in Kenya (after Highton, 1974).



cessation of irrigation at Hola since 1989 has affected the performance of the scheme and its tenants who have been unable to do any cultivation. Farmers who were previously dependent on the scheme for their livelihood have since become destitute without the means to feed and clothe themselves and their children or pay their children's educational fees. The supply of relief food is a common feature of the area.

The Bura Irrigation Settlement Project was an ambitious scheme started in 1977 to create, among other things, employment and to contribute to foreign exchange earnings through cash crops, e.g., cotton. The scheme has since collapsed due to a host of problems including the breakdown of machinery and general mismanagement. As early as 1979, the World Bank recommended abandonment of the project since it was no longer considered economically or financially viable. The original government target to settle more than 5,000 families in 23 villages to cultivate cotton and maize on 6,700 hectares of land (i.e., 1.3 ha per tenant farmer for cotton) was never achieved (JICA and Nippon Koei 1995). Currently at Bura, the settler communities and their families live in abject poverty, suffering drought and famine. The total population of about 20,000 is composed of former herdsmen or farmers who had migrated to Bura for the promise of irrigated land.

### ***Secondary Communities***

Many development projects draw poor and unemployed immigrants from a wide hinterland. As they become squatters in the project area, they are especially vulnerable to the diseases resulting from poor living conditions. They retain links with their original homes and may carry diseases back home with them to dependents who, in turn, become vulnerable. Women immigrants are particularly at risk of specific hazards, such as domestic violence, while both men and women are at risk of sexually transmitted diseases including the acquired immune deficiency syndrome (AIDS).

## **Assessment of Health Risk**

### ***Common Health Hazards***

Prior to the advent of AIDS, the most comprehensive account of health hazards in Kenya was perhaps that compiled by Vogel et al. (1974). At the time of that publication, substantial documentation already existed in relation to medical and epidemiological research in Kenya. Specific health problems discussed by the publication included communicable diseases, e.g., malaria, filariasis, meningitis and schistosomiasis; noncommunicable diseases, e.g., diabetes, cancer, malnutrition; injury, e.g., due to traffic accidents; and mental-health disorders.

The seven most common endemic communicable diseases in the Upper Tana and Lower Tana areas are shown below (table 1) ranked according to their relative occurrence during the 1990s (MoH 1996; JICA and Nippon Koei 1995; Campbell and Hodgson 1997).

*Table 1. The seven most common\* endemic communicable diseases along the Tana river basin.*

Upper Tana	Lower Tana
Malaria	Malaria
Upper respiratory tract infections	Upper respiratory tract infections
Diarrhea	Diarrhea
Eye infections	Intestinal worms
Intestinal worms	Urinary tract infections
Urinary tract infections	Gonorrhoea
Others	Schistosomiasis

\* Excluding AIDS.

Up to now, malaria has been the leading cause of morbidity and attendance at outpatient health facilities not only in the study area but generally in most of Kenya (MoH 1996). More than 5 million cases of malaria are reported in the country annually. However, despite malaria being also an important cause of inpatient admissions at various hospitals, it is of interest to note that according to unpublished reports, hospitalization due to malaria was surpassed by that due to AIDS in 1998. Both malaria and AIDS infections are present in the project area.

The two communicable diseases likely to be most impacted on by an increase in smallholder irrigation are malaria and schistosomiasis. The following risk assessment places emphasis on those two hazards in addition to malnutrition and agrochemical poisoning.

### ***Health Services***

Operations under the Ministry of Health (MoH) in Kenya can be conveniently discussed under two broad categories: a) curative services and b) preventative and promotional services (Snow et al. 1998; GoK 1991). In most cases, these services are provided on an integrated and comprehensive basis.

As regards curative services, each of about 41 districts in Kenya has a general hospital located at the district or provincial headquarters. The average number of beds in a district hospital is 200. Provinces have at least one general hospital with 500 beds on average. Services of specialists in different medical disciplines are available at the provincial hospitals.

At the local, community or village levels basic or primary health care is provided at clinics (static or mobile), health centers and dispensaries. Most of these facilities belong to the central government, local government authorities and NGOs.

Preventive and health promotional services are mainly catered for under several Divisions of MoH including the Division of Vector-Borne Diseases (DVBD) that, as part of the Division of Communicable Disease Control, works alongside other MoH Divisions, including the Division of Environmental Health, the Division of Health Education and the Health Information Systems Department. The stated objectives of the DVBD are to coordinate control of vectors of diseases in general, coordinate control of disease reservoirs, coordinate and participate in research activities related to vector-borne and parasitic diseases in general, evaluate pesticides and rodenticides for public-health use, and assist in teaching at various institutions of MoH.



Figure 1 shows the distribution of government and mission health facilities that serve the populations resident along the Tana river basin (GoK 1991; Snow et al. 1998). The highest concentration of facilities is in the more densely populated areas of central Kenya. Hospital facilities in Garissa and the Tana river districts are comparatively much fewer being only found in the Garissa town, Hola and near the delta at Garsen. The long distances that residents of the two districts must travel to the nearest hospital pose a major constraint to the timely provision of adequate health services for the majority of the population. Health services provided by the MoH in Garissa, Tana river and, to a lesser extent, in Embu and Tharaka Nithi are of necessity heavily supplemented by those from NGOs. Table 2 shows the main NGOs involved in malaria control and provision of other community-based health care services along the Tana river (Snow et al. 1998).

*Table 2. Organizations involved in malaria control and provision of other community-based health care (CBHC) along the Tana river.*

Area	District	NGO
Upper Tana	Embu	African Medical Research Foundation (AMREF)
	Tharaka Nithi	Chogoria PCEA Mission Hospital Christian Children's Fund (CCF)
Lower Tana	Garissa	Medicins Sans Frontiere (MSF), Belgium Action Nord-Sud
	Tana river	Catholic Relief Services (CRS) World Vision

## ***Malaria***

### ***Review of disease***

Malaria is endemic along the Tana river from Embu all the way to the Indian Ocean (figure 2) (MoH 1998). According to a recent classification of malaria endemicity (Snow et al. 1998), the Upper Tana area is characterized by unstable endemicity in the relatively higher and cooler areas, and low stable endemicity on lower ground. The Lower Tana area has stable endemic malaria all the way to the Kenyan coast.

In areas of unstable malaria, clinical manifestations of the disease appear seasonally during periods of peak transmission and people of all age groups may suffer severe attacks. The disease in such areas is characterized by intermittent transmission, which may be annual, biannual or variably epidemic. Districts with unstable malaria along the Tana include Embu, Tharaka Nithi and Mwingi.

Areas of stable malaria have intense perennial transmission of *Plasmodium* parasites. Severe infections are most common in children in the first 5 years of life and in women during pregnancy. The mortality rate is highest in children under 5 years of age. Partial immunity develops in communities in areas of stable malaria due to recurrent exposure to the parasite

leading to protection against severe disease in the majority of older children and adults. Districts with stable malaria within the proposed project area include the Tana river, Garissa and Lamu.

### ***Community risk factors***

*Upper Tana communities.* Generally, the local population has low immunity to malaria due to the unstable characteristics of the disease. Employment and various commercial activities generated by an increase in smallholder irrigation will attract both immune and nonimmune immigrants. The former group is likely to constitute an asymptomatic reservoir of Plasmodium parasites acquired during previous stays in areas of high endemicity.

*Lower Tana communities.* Communities in Bura, Hola and further downstream in the delta area have higher immunity to malaria than those in the Upper Tana area, due to a more extensive prior exposure to the disease. Any expansion of smallholder irrigation will lead to renewed immigration into the areas by both immune and nonimmune populations.

### ***Environmental risk factors***

Variation in climatic conditions has a profound effect on the life of a mosquito and on the development of malaria parasites (Bruce-Chwatt 1985); hence its influence on the transmission of the disease and on its seasonal incidence. The most important climatic factors are rainfall, temperature and humidity.

Rainfall exerts its influence on malaria transmission mainly through the creation of aquatic habitats that are suitable for vector breeding. The *Anopheles gambiae* species complex is the main vector of malaria in most of East Africa (Gillies and De Meillon 1968). The species complex is represented at the delta of the Tana river by a mixture of *An. gambiae s.str.* and *An. arabiensis* while the latter is the main or only species upstream in parts of Lower Tana and in all of the Upper Tana area (Mutero et al. 1999; Mutero and Birley 1987). Generally, both *An. gambiae s.str.* and *An. arabiensis* breed in a great variety of types of water, the most striking being open sunlit pools. The origin of such pools is varied and may range from hoofprints around ponds and water holes to pools resulting from the overflow of rivers, or those left behind by receding rivers. Human activity is implicit in many of these sites, especially during the reclamation of seasonal swamps for cultivation. In this connection, rice fields constitute a prolific source of *gambiae*, particularly *An. arabiensis* (Mutero et al. 1999). A flooded or partly flooded rice field presents many different types of water whose characteristics are often difficult to describe with precision. In general, rice fields are most productive of mosquitoes about 2–3 weeks after transplantation of rice seedlings. Later on, when the rice is fully grown, breeding is at a lower level and confined mainly to the margins of the fields.

As regards the influence of other climatic factors, malaria parasites cease to develop in the mosquito when the temperature is below 16 °C. The best conditions for the development of plasmodia in the *Anopheles* and the transmission of the infection are when the mean temperature is within a range of 20–30 °C, while the mean relative humidity is at least 60 percent. A high relative humidity lengthens the life of the mosquito and enables it to live long enough to transmit the infection to several persons.

*Upper Tana area.* Climatic conditions in districts serving as a catchment for the Grand Falls reservoir area vary from the modified tropical climate of the Kenya highlands to the tropical

continental/semidesert climate of eastern Kenya (Ojany and Ogendo 1988). The highland climate is characterized by high rainfall with the long rains occurring between March and May and the short rains between October and December. The continental/semiarid zone is drier, receiving less than 500 mm of annual rainfall. The mean annual minimum temperature in the modified highland climate is 15–20 °C while the mean annual maximum temperature is 25–30 °C. Temperatures in the semiarid zone are higher. The range of temperature and humidity conditions is conducive to the breeding of *Anopheles arabiensis*, the main vector of malaria in the area, especially in the Mwea rice irrigation scheme (Mutero and Birley 1987; Rapuoda 1995). The population of *An. arabiensis* is likely to expand with expansion of irrigated agriculture in the Upper Tana. The climatic conditions in the area also favor transmission of malaria parasites for most of the year.

*Lower Tana area.* Both the Tana river and the Garissa districts have a mean annual minimum temperature of more than 25 °C and a mean annual maximum temperature higher than 30 °C. Malaria levels along the Tana river flood plain are among the highest in the country (figure 2). Even so, the prevalence of *P. falciparum* at Hola was 54 percent more than in the nonirrigated surrounding area (JICA and Nippon Koei 1995). A severe outbreak of cerebral malaria that caused serious child mortality in 1981–82, leading to increased desertion of the scheme, is indicative of the seriousness of the problem. Irrigation schemes introduced in areas of high-malaria endemicity have generally led to an expansion of the malaria-vector populations that, in turn, has led to an escalation of the malaria problem (Service 1984; Renshaw et al. 1998). For instance, irrigation in the Kano plain of western Kenya led to a 70-fold increase in the main malaria mosquito while both the Mwea and Hola/Bura irrigation schemes switched to perennial rather than to seasonal malaria transmission.

Despite the collapse of the Hola and Bura irrigation systems, the number of smallholder irrigation projects has increased (JICA and Nippon Koei 1994). This development is, to a large extent, attributable to the reduction of available pasture by the limitation of annual floods, resulting from the existence of several large dams upstream. The area upstream of Garissa is, for instance, host to a large number of displaced and refugee Somali and other pastoralists, some of whom have taken up irrigated farming. In the Ngao area towards the delta, farmers now utilize floodplain land formally providing dry-season pasture for a combination of rain-fed and small-scale irrigated farming. A considerable number of oxbow lakes previously surrounded by seasonal wetlands are now under crops.

In terms of vector populations and associated malaria transmission, smallholder irrigation systems can be just as notorious as the bigger schemes if water drainage is not properly managed. Even in the large rice irrigation schemes, mosquito breeding is most prolific among the many small pools that are created by footprints during rice transplanting. Assuming that the trend in smallholder irrigation is likely to grow, especially if there were more regular floods in the Tana, the vector-breeding habitat is also likely to expand, leading to a worsening of the current malarial situation.

### ***Institutional risk factors***

Both the MoH and NGOs operating in the Upper and Lower Tana areas are involved in the promotion of insecticide-impregnated bed nets for protection against mosquito bites and malaria. Community-based structures are mainly used to initiate grassroots organizations of full-cost recovery bed-net programs. Unfortunately, the failure rate of many such community programs is high mainly because the communities cannot afford either the nets or the chemicals with which they are treated. The MoH's Division of Vector-Borne Diseases (DVBD), despite having stations at each of the sites with hospital facilities, is, to a large extent, inactive due to lack of funds for operations and vehicles. A further confounding factor for malaria is the now widespread resistance of malaria parasites to the commonly available curative drug, chloroquine. The cost of alternative drugs, e.g., Fansidar, is beyond the reach of most families.

### ***Conclusion***

An assessment based on community, environmental and institutional risk factors suggests that there will be an increase in the risk of malaria among communities living in both the Upper and the Lower Tana areas in the event of an expansion in smallholder irrigation for rice and other crops. The creation of mosquito-breeding habitats due to small-scale irrigation activities in the Upper Tana area will lead to an increase in malaria vector populations. Immigrants from malarious areas will provide a parasite reservoir that could result in malaria transmission taking place for most of the year. The vector habitat will similarly expand in the downstream area due to human activity, particularly related to trans-humance and enhanced smallholder irrigation.

### ***Schistosomiasis***

#### ***Review of disease***

The term schistosomiasis describes the pathological condition resulting from infection by flukes of the genus *Schistosoma*. Two species of the genus occur in Africa, namely *S. haematobium* and *S. mansoni*. Clinical signs for the two infections are blood in urine and blood in stools, respectively. *S. haematobium* has the highest prevalence along the Kenyan coast and in the downstream areas of the proposed Grand Falls/Mutonga project (Highton 1974) (figure 3). In 1956, when the irrigation scheme at Hola began, there were no snail vectors present on the scheme, owing to elevation of the scheme above the river and the absence of a suitable habitat for them (JICA and Nippon Koei 1995). A decade later, the prevalence of urinary schistosomiasis among Pokomo schoolchildren was 70 percent, rising by 1982 to 90 percent in Pokomo and Orma. The snail vectors for this disease in Hola and Bura areas include *Bulinus nasutus*.

*S. mansoni*, on the other hand, is absent from the coastal belt but is common in the more central areas of Kenya around Nairobi and the Upper Tana area. During the mid-1950s, an examination of 1,000 members of the indigenous population of the Embu/Kirinyaga areas failed to detect a single case of *S. mansoni* or *S. haematobium* (Highton 1974). A few years after the establishment of the Mwea rice irrigation scheme, surveys revealed a rapid increase in the prevalence of *S. mansoni* with up to 60 percent of schoolchildren having infections. The intermediate snail hosts for *S. mansoni* belong to the genus *Biomphalaria*, which has a wide

distribution in Kenya. However, *Biomphalaria* has not been reported from the coastal plain and its absence is substantiated by the lack of *S. mansoni* in the area.

### ***Community risk factors***

*Upper Tana area.* In this area, communities come into contact with infected water in the course of their routine activities e.g., washing, fishing and swimming. Immigrant workers, fisherfolk, farmers from nearby infected areas and hawkers of petty domestic merchandise can introduce the disease in their urine and excreta. It is likely that enhanced irrigation activities combined with washing and recreation on the edges of micro-dams would result in a rapid increase in the number of people infected with schistosomiasis. As discussed elsewhere in this report, a similar phenomenon has previously occurred at the Mwea rice irrigation scheme and downstream at Bura. Both these areas started with a relatively infection-free population.

*Lower Tana area.* Increased expansion of smallholder irrigation will lead to renewed immigration into various downstream sites by farm workers and petty business people. Some pastoralists will also convert to a more sedentary life, which will bring them into more frequent contact with water for irrigation. An established human reservoir of schistosomiasis infection already exists in the local population and will spread to more people.

### ***Environmental risk factors***

*Upper Tana area.* Development of water utilization projects for hydropower and irrigation schemes has, during the last few decades, provided ideal habitats for vector snails of intestinal schistosomiasis in the Tana river basin upstream of the proposed Grand Falls/Mutonga project. *S. mansoni* is, therefore, present in Upper Tana areas. In one of the main foci of *S. mansoni*, namely the Mwea rice irrigation scheme, control of vector snails has, in the past, involved the application of molluscicides to the snail habitats, and proper maintenance of canals. Currently, the management of the irrigation scheme is in transition from the centrally managed structure of the government-owned National Irrigation Board (NIB), to community-run grassroots organizations. A decline in previous standards of snail control could lead to an increase in the snail populations in the scheme and, in turn, to an increased risk of their being washed downstream to other areas of the Tana river basin.

*Lower Tana area.* Snail vectors of urinary schistosomiasis are well established in Bura and Hola irrigation schemes (JICA and Nippon Koei 1995). They include *Bulinus globosus* and *B. nasutus*. The snails breed in poorly maintained irrigation channels. The collapsed state of both Bura and Hola schemes is potentially conducive to large increases in vector snail populations in the event of renewed irrigation activities. Snail populations flushed down from these areas by regular floods could easily end up as an addition to local colonies in the more recently established smallholder irrigation schemes further downstream.

### ***Institutional risk factors***

Both the Upper Tana and Lower Tana areas where schistosomiasis is a major health hazard have access to facilities that could play a role in schistosomiasis control, including hospitals and laboratories of the DVBD. The preventive role of the DVBD would be the most effective approach in the control of schistosomiasis compared to the curative approach of many hospitals

(Verhoef 1996). Unfortunately, operations of the DVBD are often hampered by lack of facilities and vehicles, and the fact that members of the staff are normally idle and demoralized.

### ***Conclusion***

The assessment concludes that there will be an increase in intestinal schistosomiasis in the Upper Tana and Lower Tana areas in case of increased irrigation activities.

### ***Human Nutrition***

#### ***Review of disease***

Protein calorie malnutrition (PCM) is, in Kenya, one of the main public-health problems as it is in most tropical countries with a predominantly rural population (Blankhart 1974). The major types of PCM in Kenya are kwashiorkor and marasmus. Kwashiorkor refers to the disease of the child weaned too early on a low protein staple diet, usually maize. Kwashiorkor is caused by an unbalanced food intake with relative excess of carbohydrates and lack of proteins. Predisposing factors for kwashiorkor include infections such as measles, tuberculosis and enteritis. Marasmus, on the other hand, is due to a total lack of food, proteins as well as calories. It may affect the infant in its first 9 months of life if breast-feeding is inadequate. It occurs in older children when there is disease or shortage of food. However, to a large extent, it seems to be associated with unhygienic bottle-feeding often resulting in diarrhea.

#### ***Community risk factors***

Famine is a perennial problem in some of the districts in both the reservoir and downstream areas including Mwingi, Garissa and Tana river district. Famine relief has been a feature of the Tana river district since the collapse of the Hola and Bura irrigation schemes about a decade ago (JICA and Nippon Koei 1995). Both marasmus and kwashiorkor are prevalent in the downstream districts. A survey conducted in the 1980s showed that 52 percent of the children in the Bura division were malnourished. Despite comparatively higher levels of nutrition in the reservoir area, the situation could change for the worse during resettlement of displaced communities.

#### ***Environmental risk factors***

Part of the reservoir and all of the two main downstream districts are semiarid and prone to frequent severe droughts. The droughts seriously affect crop yields and animal communities. There is also a general lack of security, particularly in the Tana river and Garissa districts where bandit attacks are common.

#### ***Institutional risk factors***

In the past, the Government of Kenya supplied relief food to the Tana river district, with assistance from the World Food Programme, CARE and Catholic Relief Services. A lack of adequate government resources combined with insecurity in the downstream area poses a big problem to the effective distribution of relief food.

## ***Conclusion***

The assessment concludes that increased irrigation will improve food production systems along the length of the Tana river basin and, in turn, maintain good nutrition among the resident communities.

## ***Other Hazards***

### ***Review of disease***

Other hazards associated with irrigation might include injury from irrigation equipment and agrochemical poisoning.

### ***Community risk factors***

An increase in irrigated crop production would result in increased movement of both secondary and primary communities in the Upper and Lower Tana areas. This movement would be mainly related to transportation of produce to various markets including Nairobi. The Kenyan public-transport system is prone to high accident rates and it is likely that many people will get involved in vehicle accidents.

### ***Environmental risk factors***

Expansion of irrigated agricultural production, particularly for vegetables, e.g., tomato, kale, etc., will lead to increased use of pesticides and, consequently, risk of death from accidental poisoning or when pesticides are used to commit suicide. In the Lower Tana area, agrochemical poisoning could be confounded by the washing down from the Upper Tana of additional persistent organic pollutants, e.g., organochlorine pesticides.

### ***Institutional risk factors***

Hospital facilities in both the Upper and Lower Tana areas are, like in many other places in Kenya, inadequate under the best of times. Any increases in the local population due to an influx of people into an area with expanded irrigation activities will lead to a further deterioration in the currently available health care, unless provision for additional services is made. As regards vehicle accidents, the prevailing poor road maintenance combined with unchecked corruption in the ranks of traffic police officers have all contributed to the existing poor road-safety record for Kenya.

## ***Conclusion***

The assessment concludes that there will be an increased risk of road accidents and other forms of injury in the event of a significant expansion in irrigated agriculture. Stress-related problems are also likely to be experienced among Lower Tana communities during months of water scarcity. The communities already blame upstream activities, e.g., the damming of the Tana for the disappearance of the regular annual floods and the subsequent economic deterioration of their areas (AIC 1995). By extension of this line of reasoning, expanded irrigation in the upper Tana area is likely to be blamed for downstream water shortages and is a potential source of conflict between the downstream and upstream communities.

### ***Risk Management and Mitigation Measures***

In selecting mitigation measures for a development project, higher priority should be given to interventions with a positive impact on the general health status than to disease-specific interventions (Konradsen et al. 1997; Verhoef 1996). In the case of expansion in irrigation activities, general poverty is obviously among the more serious fundamental problems facing the stakeholder communities. Thus, a strengthening of production and marketing systems aimed at economic empowerment would rank high among measures for health improvement and the general well-being of the communities.

For malaria and schistosomiasis, a community-based health education program for promoting awareness about the diseases and available control options should be implemented at the start of expansion of irrigation activities in a given area. In the case of malaria, screening the eaves and windows of houses with mosquito-proof mesh wire could be a cost-effective method of reducing mosquito-person contact. Both the government and the NGOs should support communities in setting up sustainable systems for provision of insecticide-treated mosquito nets and antimalarial drugs. These measures are especially important if increased mortality is to be avoided among the high-risk groups including pregnant women, and children under 5 years. As regards schistosomiasis, swimming by children in infected water is considered to be the most important factor continuing or increasing disease transmission (Renshaw et al. 1998). It would be of benefit if villages along the Tana river were provided with snail-free bathing areas. These should be centrally sited, concrete-lined and protected from snail colonization. Latrine provision is also an essential element in the control of schistosomiasis. Therefore, there is a need for the promotion of improved and long-lasting latrines.

### **Conclusion**

The present HIA shows that an increase in irrigation along the Tana river basin will enhance agricultural production systems and contribute to improved human nutrition and well-being among downstream communities. However, there will also be an increase in the risk of a number of communicable diseases including malaria and schistosomiasis. Safeguards against the negative impacts should be incorporated at the earliest opportunity to maximize their effectiveness.



## Literature Cited

- Acropolis. 1995. *Phase 3. Environmental impact assessment. Mutonga Grand Falls hydropower project. Summary of previous study results phases 1 and 2.* Nairobi: Acropolis Kenya Ltd.
- AIC (Agricultural Information Centre). 1995. *The Tana river.* Video. Nairobi: Ministry of Agriculture.
- Birley, M.H. 1995. *The health impact assessment of development projects.* London: Her Majesty's Stationery Office.
- Birley, M.; M. Gomes; and A. Davy. 1997. *Health aspects of environmental assessment. Environmental assessment sourcebook Update.* No. 18. Environment Department. Washington, D.C. The World Bank.
- Blankhart, D. M. 1974. Human nutrition. In *Health and disease in Kenya*, ed. L. C. Vogel, A. S. Muller, R. S. Odingo, Z. Onyango, and A. De Geus. Nairobi: East African Literature Bureau.
- Bolton, P.; A. M. A. Imevbore; and P. Fraval. 1990. *A rapid assessment procedure for identifying environmental and health hazards in irrigation schemes: Initial evaluation in northern Nigeria.* Report OD 120. Wallingford: Hydraulics Research Ltd.
- Bruce-Chwatt, L. J. 1985. *Essential malariology.* Second edition. London: William Heinemann Medical Books.
- Campbell, K.; and N. Hodgson. 1997. *Feasibility study on Grand Falls/Mutonga hydropower project.* Supporting Report (2). EA. CD ROM.
- Gillies, M. T.; and B. De Meillon. 1968). *The Anophelinae of Africa south of the Sahara.* (Ethiopian zoogeographical region). Second edition. Durban, South Africa: South African Institute of Medical Research.
- GoK (Government of Kenya). 1991. *National atlas of Kenya.* Fourth edition. Kenya.
- Highton, R. B. 1974. Schistosomiasis. In *Health and disease in Kenya*, ed. L. C. Vogel, A. S. Muller, R. S. Odingo, Z. Onyango, and A. De Geus. Nairobi: East African Literature Bureau.
- JICA (Japan International Cooperation Agency); and Nippon Koei. 1994. *Environmental impact assessment. Stage 2. Grand Falls Hydropower Project. Farming Systems in the Middle and Lower Tana Basin.* Draft Report. Nairobi: JICA and Nippon Koei Ltd.
- JICA; and Nippon Koei Ltd. 1995. *Initial environmental impact assessment.* The proposed rehabilitation of the Bura and Hola irrigation schemes. Draft Report. Nairobi. JICA and Nippon Koei Co. Ltd.
- Konradsen, F.; M. Chimbari; P. Furu, M. H. Birley; and N. O. Christensen. 1997. The use of health impact assessments in water resources development: A case study from Zimbabwe. *Impact Assessment* 15: 55–72.
- Lacey, L. A.; and C. M. Lacey. 1990. The medical importance of riceland mosquitoes and their control using alternatives to chemical insecticides. *J. Am. Mosq. Control Assoc.* 6: 1–93.
- MoH (Ministry of Health). 1996. *Briefing paper for the Kenya national plan of action for malaria control.* Kenya.
- MoH. 1998. *National guidelines for diagnosis, treatment and prevention of malaria for health workers.* Kenya.
- Mutero, C. M.; H. Blank; W. Konradsen; and W. van der Hoek. 1999. Water management for controlling the breeding of *Anopheles* mosquitoes in rice irrigation schemes in Kenya (submitted to *Acta Tropica*).
- Mutero, C. M.; and M. H. Birley. 1987. Estimation of the survival rate and oviposition cycle of field populations of malaria vectors in Kenya. *Journal of Applied Ecology* 24: 853–863.
- Ojany, F. F.; and R. B. Ogendo. 1988. *Kenya: A study in physical and human geography.* Nairobi, Kenya: Longman.

- Ominde, S. H. 1974. Demography and ethnic groups. In *Health and disease in Kenya*, ed. L. C. Vogel, A. S. Muller, R. S. Odingo, Z. Onyango, and A. De Geus. Nairobi: East African Literature Bureau.
- Rapuoda, B. A. 1995. Ecological and behavioural studies of mosquitoes in Mwea Tebere irrigation scheme, Kirinyaga district, Kenya, with special reference to *Anopheles gambiae* complex. Ph.D. diss. Kenyatta University, Nairobi.
- Renshaw, M.; M. H. Birley; D. K. Sang; and J. B. Silver. 1998. A rapid health impact assessment of the Turkwell gorge hydroelectric dam and proposed irrigation project. *Impact Assessment and Project Appraisal* 16: 216–226.
- Service, M. W. 1984. Problems of vector-borne diseases and irrigation projects. *Insect Science and Its Application* 5: 227–231.
- Snow, B.; H. Mwenesi; and B. Rapuoda. 1998. *Malaria: A situation analysis for Kenya*. Nairobi, Kenya: Ministry of Health.
- Surtees, G. 1970. Effects of irrigation on mosquito populations and mosquito-borne disease in man, with particular reference to rice field extension. *International Journal of Environmental Studies* 1: 35–42.
- Verhoef, H. 1996. Health aspects of Sahelian floodplain development. In *Water management and wetlands in sub-Saharan Africa*, ed. M. C. Acreman and G. E. Hollis. Verhoef, Switzerland: The World Conservation Union (IUCN).
- Vogel, L. C.; A. S. Muller; R. S. Odingo; Z. Onyango; and A. De Geus, eds. 1974. *Health and disease in Kenya*. Nairobi, Kenya: East African Literature Bureau.
- WHO (World Health Organization). 1986. *Intersectoral action for health: The role of intersectoral cooperation in national strategies for health for all*. Geneva.



# Integrated Pest Management (IPM) Issues in Irrigated Agriculture: Current Initiatives and Future Needs to Promote IPM Adoption by Smallholder Farmers in Eastern Africa

*S. Sithanantham, A. A. Seif, J. Ssenyonga, C. Matoka and C. Mutero<sup>1</sup>*

## **Abstract**

Irrigated agriculture is characterized by intensive land use and substantial use of external inputs. Intensive and year-round production of crops, particularly vegetables, under irrigation induces the continuous presence (and buildup) of pests and diseases, which often reach epidemic proportions. Growers, who are mostly smallholders, are prompted to increasingly depend on pesticides to protect their crops. This trend, if not corrected, will lead to environmental pollution, buildup of resistance in pests and diseases, destruction of beneficial arthropods, buildup of hitherto minor pests and unacceptable levels of pesticide residues in vegetable produce. Although pests and diseases are reckoned as major constraints to production of irrigated crops in Eastern Africa, there is a lack of quantitative data on the production losses they cause.

Against this background, this paper discusses the need and scope for promoting Integrated Pest Management (IPM) as a strategy for sustainable protection and production of irrigated crops. While the sustainability of irrigated agro-ecosystems is the base for developing strategies for sustainable irrigated crop production by smallholder farmers, available relevant research information within the region is scanty. The importance of multidisciplinary and collaborative research for evolving ecologically friendly pest management and related cropping practices in irrigated agro-ecosystems is highlighted in a case study of the Mwea rice irrigation scheme in Kirinyaga, Kenya. Also addressed in detail are IPM sectors for smallholders in irrigated agriculture: needs, training, adoption, examples of IPM measures for vegetables, and initiatives in the region. The experience gained from the joint initiative of the ongoing International Centre of Insect Physiology and Ecology (ICIPE) with national partners for the development of suitable models for IPM awareness-building among the farmers could be utilized for expanding the impact of IPM in irrigated agriculture. The potential for IPM as a useful component of regional initiatives is illustrated. The major theme areas suggested for a future IPM focus include a) choice of irrigation methods and regimes that favor cost-effective pest management, b) the choice of environmentally friendly pest and crop management options that favor the conservation of beneficial fauna and flora in the agro-ecosystem, and c) harmonizing policy and community issues with IPM awareness for catering to improvement in the farming systems and community health.

---

<sup>1</sup>S. Sithanantham is Senior Scientist, International Centre of Insect Physiology and Ecology, Nairobi, Kenya/IPM Specialist and Co-coordinator, Regional Vegetable Network for eastern Africa. A.A. Seif, J. Ssenyonga, C.M. Matoka and C. Mutero are Plant Pathologist, Social Scientist, Research Associate, and Senior Scientist, respectively, of the International Centre of Insect Physiology and Ecology, P.O. Box 30772, Nairobi, Kenya, e-mail: [icipe@icipe.org](mailto:icipe@icipe.org)

## **Pests and IPM Issues in Irrigated Agriculture**

### ***Potential Role of Irrigation in Pest Problems***

Intensive use of land and greater investment in external inputs are visualized as the major thrust in enhancing the profitability in irrigated agriculture. With improved access to irrigation, smallholder farmers tend to grow crops almost year-round, as a means of enhanced income generation. Such an overlap in crops enhances pests to continuously multiply, resulting in their greater severity. As a consequence, farmers either incur greater production losses or need to spend more for achieving adequate levels of pest control. Increased risks of crop losses or additional control costs should be taken into account in planning irrigated cropping systems.

### ***Relative Importance of Common Pest Problems on Major Irrigated Crops***

It is known that the common irrigated cropping systems, such as rice and vegetables, are prone to attack by a wide range of pests and diseases in Eastern Africa (table 1). Important pests include those living below the soil surface (e.g., termites, cutworms), foliage feeders (e.g., beetles, caterpillars), miners/borers (e.g., fruit borers, stem miners, leaf miners) and sucking pests (e.g., aphids, thrips, white flies, spider mites and bugs). Diseases of importance on these crops range from soil-borne pathogens (damping off, foot rot, wilts) to leaf diseases (blast, blight, rust) and those causing rotting of vegetative parts (stem rot, sheath rot) and reproductive parts (e.g., black rot, fruit rot). Nematodes often constitute an important biotic constraint to irrigated crop production.

Quantitative data on the extent of production losses caused by pests and diseases on these irrigated crops in Eastern Africa are scanty. However, a reasonable guesstimate of the commonly experienced losses in these crops due to pests and disease in the region would be 10 to 40 percent. It is important to assemble baseline information on the relative economic importance of the commonly occurring pests and diseases in the representative production ecologies of the region. Such information can be utilized in prioritizing the regional pest problems and in developing relevant options for their management.

## **IPM and Crosscutting Issues for Sustainability of Irrigated Agriculture**

IPM is an approach that seeks to minimize and rationalize the use of chemical pesticides as well as promote the use of safer alternatives to pesticides (e.g., biocontrol, cultural practices). The goal for IPM is agro-ecosystem sustainability through the adoption of appropriate strategies that contribute to conservation of the biodiversity and activity of beneficial organisms in the farming system. Since intensive cultivation of crops is a feature of irrigated agriculture and external inputs often figure prominently in these cropping systems, IPM becomes more a need than an option in such systems. IPM seeks to ensure that we do not “destroy” the “beneficial insects” (e.g., predators, parasitoids), or “neglect” their role while adopting pest-control methods since they are “friends of the farmer” and help keep the pest populations under check. The extent to which IPM is appreciated/adopted by farmers will also influence the reduction in pesticide use (or misuse) in the ecosystem.

Table 1. List of common pest-disease problems on irrigated rice and vegetables in Kenya.

Crop	Pest/Disease	Common Name	Scientific Name	Relative Importance
Rice	Pest	Stem borer	<i>Chilo partellus</i>	**
	-do-	Leaf hoppers	<i>Cicadella spectra</i>	**
	-do-	Case worm	<i>Nymphula depunctalis</i>	*
	-do-	Stalk-eyed fly	<i>Diopsis thoracica</i>	*
	Disease	Blast	<i>Pyricularia oryzae</i>	***
	-do-	Sheath blight	<i>Rhizoctonia solani</i>	*
	-do-	Sheath rot	<i>Acrocynlindrium oryzae</i>	*
	-do-	Brown spot	<i>Helminthosporium oryzae</i>	*
	-do-	Stem rot	<i>H. sigmoideum</i>	*
Onion	Pest	Thrips	<i>Thrips tabaci</i>	***
Tomato	-do-	Leaf miner	<i>Liriomyza</i> sp.	**
Tomato	-do-	African bollworm	<i>Helicoverpa armigera</i>	*
Tomato	-do-	Whitefly	<i>Bemisia tabaci</i>	**
Tomato	-do-	Spider mite	<i>Tetranychus</i> spp.	**
Cabbage/Kale	-do-	Diamondback Moth (DBM)	<i>Plutella xylostella</i>	***
Cabbage	-do-	Cabbage aphid	<i>Brevicoryne brassicae</i>	**
Tomato	Disease	Bacterial wilt	<i>Ralstonia solanacearum</i>	***
Tomato	-do-	Root-knot Nematodes	<i>Meloidogyne</i> spp.	***
Tomato	-do-	Early blight	<i>Alternaria solani</i>	*
Onion	-do-	Purple blotch	<i>A. porri</i>	**
Onion	-do-	Rust	<i>Puccinia porri</i>	*
Onion	-do-	Basal rot	<i>Fusarium oxysporium</i>	
			f. sp. cepae	*
Cabbage/Kale	-do-	Black rot	<i>Xanthomonas campestris</i>	
			pv. campestris	***

Note: \*\*\* = very important; \*\* = important; \* = less important.

### ***Interaction of Irrigation with Agro-Ecosystem Sustainability***

An important area of study is the effect of irrigation methods and the intensity/frequency of watering on the severity of pests/diseases. Drip irrigation is thought to be more desirable, as the risk of spread of soil-borne problem (e.g., nematodes, and wilts) is apparently less than with furrow and other forms of irrigation. Sprinkler irrigation may result in washing down of some pests (e.g., aphids, spider mites, thrips), but may enhance risks of some foliar diseases (due to leaf surface wetness favoring the germination of spores). Flooding (keeping water inundated) is known to suppress some soil pests (e.g., white grubs) and diseases (e.g., Fusarium wilt of tomato). Although there is no published information available in the region, the knowledge available elsewhere (table 2) could be useful in planning suitable adaptive research/verification trials.

Table 2. Examples of known effects of irrigation (methods and regimes) on pest/disease severity in crops from elsewhere.

Crop	Target Pest/Disease	Irrigation/ Treatment Studied	Country	Type of Effect Observed (+ = positive effect - = negative effect 0 = no effect)	Reference
Apple ( <i>Malus domestica</i> ; <i>M. pumila</i> )	Codling moth ( <i>Cydia pomonella</i> )	Overhead watering	USA	Irrigation (+)	Knight 1998
Corn ( <i>Zea mays</i> )	Corn earworm ( <i>Helicoverpa zea</i> )	Furrow irrigation	USA	Larval parasitism by nematodes (-)	Cabannillas and Raulston 1996
Cotton ( <i>Gossypium hirsutum</i> ; <i>G. barbadense</i> )	Whitefly ( <i>Bemisia tabaci</i> )	Biweekly and weekly irrigation	USA	Weekly better than biweekly (+)	Flint et al. 1996
Groundnut ( <i>A. hypogaea</i> )	Stem rot of peanut ( <i>Sclerotium roffsii</i> )	Irrigation	USA	Irrigation (-)	Davis et al. 1996
Potato ( <i>S. tuberosum</i> )	Colorado potato beetle ( <i>Leptinotarsa decemlineata</i> )	Leaf mulch and trickle irrigation	USA	Both treatments (+)	Stoner 1993
Rye grass ( <i>Lolium perenne</i> )	Brown patch ( <i>Rhizoctonia solani</i> ), dollar spot ( <i>Sclerotinia homoeocarpa</i> )	Daily irrigation and irrigation based on anemometer estimated ET	USA	Irrigation (-) for brown patch (-) for dollar spot	Jiang et al. 1998
Soybean ( <i>Glycine max</i> )	Soybean looper ( <i>Trichoplusia sp.</i> )	Irrigation	USA	Irrigation (0)	Lambert and Heatherly 1995
Tomato ( <i>Lycopersicon esculentum</i> ), Eggplant ( <i>Solanum melangena</i> )	Thrips ( <i>Frankliniella occidentalis</i> ) and Aphids ( <i>Myzus persicae</i> )	Ebb-and-flow irrigation	USA	Irrigation (-)	Latimer and Oetting 1994
Bantley ( <i>Hordetum vulgare</i> )	Termites (Termitidae)	Irrigating once or twice	India	Irrigation (+)	Bhanot and Verma 1990
Cabbage ( <i>Brassica oleracea</i> var. <i>capitata</i> )	Diamond back moth ( <i>Plutella xylostella</i> )	Sprinkler irrigation applied 5 minutes at dusk on alternate days over the first 3-4 weeks and everyday afterwards	Taiwan	Irrigation +	Talekar et al. 1986
Cucumber ( <i>Cucumis melo</i> )	Thrips ( <i>Thrips tabaci</i> )	Sprinkler irrigation and drip irrigation	Switzerland	Sprinkler was preferable for reducing the number of thrips	Bieri et al. 1989
Cucumber ( <i>C. melo</i> )	Downy mildew ( <i>Pseudoperonospora cubensis</i> )	Drip irrigation every 3-4 days	Belgium	Irrigation (-)	Milevoj and Osvald 1994
Faba bean ( <i>Vicia faba</i> )	Aphids ( <i>Aphis fabae</i> and <i>Erynia neoaphidis</i> )	Irrigation	UK	Irrigation (+)	Wilding et al. 1986
Groundnut ( <i>Arachis hypogaea</i> )	Leafminer ( <i>Approaema modicella</i> )	Increased level of irrigation	India	Increased level of irrigation (+)	Kusmenwar and Deshpande 1991
Groundnut ( <i>A. hypogaea</i> )	Leafminer ( <i>A. modicella</i> )	Overhead irrigation	India	Irrigation intensity (+)	Wheatley et al. 1989

Table 2. Continued.

Crop	Target Pest/Disease	Irrigation/ Treatment Studied	Country	Type of Effect Observed (+= positive effect - = negative effect 0 = no effect)	Reference
Lentil ( <i>Lens culinaris</i> )	Ascochyta blight ( <i>Ascochyta fabae</i> )	Irrigation	New Zealand	Irrigation (-)	Knight et al. 1989
Lucerne ( <i>Trifolium alexandrinum</i> )	Leaf caterpillar ( <i>Spodoptera litoralis</i> )	Flood irrigation	Arabia	Irrigation (+)	El-Sherif and Badr 1992
Peas ( <i>Pisum sativum</i> )	Cutworms ( <i>Agrotis biconica</i> and <i>Mythimna separata</i> ).	Irrigation	India	Irrigation (+)	Prasad et al. 1987
Pepper ( <i>Capsicum annuum</i> )	Root rot of pepper ( <i>Phytophthora capsici</i> .)	Drip irrigation	Brazil	15 cm deep (+)	Café Filho and Dumitway 1996
Potato ( <i>Solanum tuberosum</i> )	( <i>Tecia solanivora</i> and <i>Prennotrypes vorax</i> )	3 irrigation frequencies evaluated (5,6 and 8)	Venezuela	Irrigation at 6-day intervals (+)	Fernandez 1997
Rice ( <i>Oryza sativa</i> )	Rice mealy bug ( <i>Brevinnia rehi</i> )	3 irrigation regimes compared: continuous ponding at a depth of 5 cm, irrigation to 5 cm of water at reproductive phase and irrigation to 5 cm each day after the disappearance of pond water	India	Continuous ponding at 5 cm (+)	Gropalan et al. 1987
Rice ( <i>O. sativa</i> )	( <i>Oryza matsumura</i> )	Irrigation	China	Irrigation (+)	Yan et al. 1981
Sorghum ( <i>Sorghum vulgare</i> )	Shootfly ( <i>Atherigona soccata</i> )	Irrigation in post-rainy season	India	Irrigation (-)	Nwanze et al. 1996
Sugar beet ( <i>Beta vulgaris</i> )	Root aphid ( <i>Pemphigus fuscicornis</i> )	Intense irrigation	Belgium	Irrigation (+)	Ioannidis 1996
Sugar beet ( <i>B. vulgaris</i> )	Caterpillars ( <i>Pegomya hyoscyami</i> and <i>Scrobipalpa ocellatella</i> )	Irrigation	Egypt	Irrigation (+)	Mesbah et al. 1985
Sugarcane ( <i>Saccharum officinarum</i> )	Stem borers ( <i>Chilo infuscatellus</i> and <i>Emmalocera depressella</i> )	Timing irrigation at an interval of 10 days	India	10-day interval (+)	Mrig et al. 1995
Sugarcane ( <i>S. officinarum</i> )	Stem borers ( <i>Scirpophaga excerptalis</i> , <i>C. infuscatellus</i> )	Irrigation at an interval of 12-14 days and irrigation at a ratio equivalent to the soil water content	India	Both types of irrigation (-)	Singla and Duhra 1990
Sugarcane ( <i>S. officinarum</i> )	Stalk borers ( <i>C. infuscatellus</i> ). Scale insects ( <i>Melanaspis glomerata</i> ) and Mealy bug ( <i>Saccharicoccus sacchari</i> )	Drip irrigation Traditional flood method	India	Increased irrigation intervals (+)	Parsama et al. 1994
Sunflower ( <i>Helianthus annuus</i> )	Severe Rutherglen bug ( <i>Nysius vinitor</i> )	Irrigation	Australia	Yield loss due to bugs (+)	Forrester and Saini 1982



### *IPM Linkages to Community and Environmental Concerns*

The broad goal objective of IPM is the optimization of the entire crop/livestock system rather than maximization of returns. The definition of IPM, as the application of different pest-control tactics compatibly so as to promote the health of crops, can be extended to cover the health of livestock, people or a combination of these, and in a manner that integrates the control tactics into local/or large human, agricultural and ecological systems on a sustainable basis. The realization of these objectives for IPM in irrigated agriculture in Africa will require two initiatives. The first is the development of reliable, practical and cost-effective tools, which farmers can use in pest and disease management. Simple but reliable guidelines need to be offered for pest monitoring such as those based on crop-development cycles in irrigated rice farming (Heong and Escalada 1997). The second task is to develop simple learning-by-doing tools to enable farmers to deal with the knowledge/management intensity of IPM. Successfully implemented approaches for farmers in integrated agriculture include farmers' field schools (FFS) and farmer-to-farmer extension. These and other approaches should be available to the farmers in irrigated agriculture in East Africa.

*Table 3. Examples of methodologies used in the study of nontarget effects of pest-control/irrigation practices adopted for cotton.*

Pest Control/ Irrigation Method	Target Pest Studied	Nontarget Group Studied	Method Adopted	Reference
Pesticide use	<i>Helicoverpa armigera</i>	Natural enemies	Predatory activity (secondary effects)	Hamburg and Guest 1997
Biological control using coccinellids	—	-do-	Evaluation techniques (specificity assessment)	Obrycki and Kring 1998
IPM	Arthropod pests	-do-	Arthropod conservation	Kogan and Latin 1993
Irrigation	Lepidoptera	—	Pest population dynamics	Perfect 1986
Semiochemicals	<i>Heliothis zea</i>	Natural enemies (esp. <i>Trichogramma</i> spp.)	Enhancement of natural enemy effectiveness	Lewis and Nordlund 1985
Selective pesticides	—	Natural enemies	Nutritional restraints, endocrine events, physiological and behavioral strategies	Mullin and Croft 1985
Microbial insecticides	Various pests	Natural enemies	—	Falcon 1985

## **Understanding IPM Needs of Farmers**

### ***Aspects and Approaches to Understanding IPM Needs of Farmers***

The task of understanding farmers' IPM needs will entail understanding the end users' production objectives, constraints, resources, and differing socioeconomic and agro-ecological situations.

#### ***Production objectives***

Four major kinds of production objectives stand out as follows: a) food and food security, b) cash needs, c) health needs, and d) social needs (rituals, status, etc.). In sub-Saharan Africa, where external agencies tend to focus on irrigation in terms of food and food security, it is common that public policy and donors emphasize the production of cash crops to generate or save foreign exchange. This is the reason for cotton, sugarcane and rice to have dominated in irrigation projects. However, small-scale traditional irrigation systems focus on food production (Moris and Thom 1987). In recent years, small-scale farmers have undertaken horticultural production to earn cash income. As is shown elsewhere in this paper, crop protection programs in irrigated agriculture in general and pest and disease management in particular, focus on cash crops. Indeed, most discussions on IPM in irrigated agriculture in Africa are restricted to cotton, sugarcane and rice (Moris and Thom 1987). The new focus on smallholders will entail focus on IPM for cash and food crops under the region's common irrigation systems.

#### ***Constraints***

In the context of agriculture in eastern Africa, the most commonly identified constraints are a) pests and diseases, b) poor soils, c) lack of planting materials, and d) socioeconomic bottlenecks (lack of labor capital, inputs, poor market and transportation infrastructure, weak extension, etc.). It is clearly recognized that pest/vector management should be considered only if crop or livestock losses due to the pest or the vector present significant production constraints relative to other factors that compete for investment (Kiss and Meerman 1991).

#### ***Resources***

The most important resources include land, capital, labor, inputs, planting material and in the context of irrigation, water and engineering structures. Provision of these resources in irrigated agriculture is the single-most constraining factor in Africa. Montgomery's (1983) comparative study rated the Mwea irrigation scheme in Kenya as the only example of a moderately successful irrigation scheme in Africa. To be able to keep up control, governments have appropriated to themselves the ownership of water resources and land under irrigation. Under these conditions farmers were, for the most part, tenants with insecure rights (Tiffen 1987). Pest control was, for the most part, carried out by the irrigation agencies using mostly chemical pesticides. Little has been done to integrate crop pest control into the management of vectors and vector-borne diseases. Furthermore, pest and disease control in traditional irrigation systems has not received attention from the private- and public-sector institutions. Part of the problem stems from the weak institutional bases and the lack of the critical mass of multidisciplinary human resources to develop policy, and plan and implement IPM in irrigated agriculture.

### ***Differing socioeconomic and farming conditions***

Farmers' needs vary by socioeconomic strata, farming systems, culture, gender, mode of adaptation and other factors. Kiss and Meerman (1991) identify three broad classes of farmers and associated kinds of IPM needs in Africa: For subsistence farming, IPM should aim at increasing the level and reliability of production. For intensive farming relying on high levels of external inputs, IPM should seek to reduce costs, ecological disruptions and health hazards. For farmers in transitional systems (between subsistence and intensive-farming systems) IPM should aim at promoting yield increases without overusing pesticides. Farmers using chemical pesticides and other high external inputs intensely are often the first to turn to IPM strategies, since the approach offers economic incentives.

Farmers in indigenous irrigation systems approximate subsistence farmers while farmers engaged in irrigated horticulture may well fit the label "transitional." Irrigated large-scale public agriculture, though not necessarily the tenant farmers in it, fit the conditions of intensive-farming systems. As indicated earlier, the pest/disease-management practices of farmers practicing indigenous irrigated agriculture (crop rotation, fallowing, use of resistant cultivars, bush burning, etc.) are the least known. The IPM needs of women and pastoralists under public-funded, medium- and large-scale irrigated systems seem to pose difficult challenges.

A clear understanding of the end users' production systems, objectives, constraints, resources bases, and varying socioeconomic and farming systems described above will, therefore, be useful in visualizing the focus and adoption of IPM.

### ***Understanding the IPM Needs of Smallholder Farmers in the Region***

Assessing the IPM needs of smallholder farmers in irrigation-project areas can provide a basis for appropriate training and information-dissemination initiatives. As an illustration, the results from a recent four-country baseline survey (of about 60 vegetable farmers per country) in Kenya, Ethiopia, Uganda and Tanzania jointly undertaken by ICIPE and national partners is described in this section.

### ***Farmers' awareness of names of pests/diseases on vegetable crops***

The survey results pointed out that there is a great gap in the farmers' awareness of the pest problems in vegetable crops, more so among the crops grown for export. In general, it was observed that except for tomato, the majority of farmers in all the countries were not aware of even the name of any one pest occurring on seven other income-generating vegetable crops grown in the region for urban/export markets. The assessment of farmers' awareness of the names of insect pests infesting the main crops in the four countries (table 4) indicated that there was considerable variation in the awareness of pest names between the farmers in the four countries. For instance, the proportion of farmers recognizing any insect pest by name was greater among the more commonly grown vegetables like tomato, cabbage and onion than among those grown for export such as French bean, okra, brinjal, capsicum and cucurbit. Among the individual crops, the number of farmers who knew the names of pests on tomato by name were the highest in all the countries, while the overall proportion of farmers who knew the names of pests on okra was the least.

Table 4. Percent of farmers aware of names of pests in major vegetable crops, survey in four countries in eastern Africa, 1998-99.

Crops	Kenya (n=60)	Uganda (n=60)	Tanzania (n=40)	Ethiopia (n=30)	Overall (n=200)
Tomato	77	40	87	83	72
Cabbage	22	22	23	48	29
Onion	5	7	8	48	17
Capsicum/Chili	7	31	31	0	17
French bean	31	2	0	0	8
Okra	0	7	13	0	5
Brinjal/Egg plant	12	18	15	0	11
Cucumber/Karela	13	2	33	0	12

Source: ICIPE-IFAD-USAID-NARS IPM network project.

### ***Farmers' sources of advice/information on pesticide use***

The survey also indicated that the predominant sources of advice/information to the farmers on pesticide use were agro-input shops or local pesticide stockists and, to some extent, their neighboring farmers. Some farmers depended on information from labels or technical handouts. By contrast, only a smaller proportion of farmers received advice from professional extensionists. Evidently, many farmers do not have adequate access to dependable and precise advice on choice of pesticides for use in relation to the pest problems on target crops. This assessment has helped in prioritizing the local-level strengthening of farmers' access to technical information relating to appropriate and selective use of pesticides.

### ***Farmers' perceived constraints to pest control***

The areas of information needs or constraints to pest control perceived by the participating farmers mainly relate to safe, rational and effective choice of pesticides. Second, they relate to their interest in more knowledge in identifying the different pests (and diseases). Enhancing their ability to correctly diagnose the pests was perceived as a critical way forward to enable them to select and use pesticides appropriately. Farmers also reckoned that they needed technical advice on safer alternatives to pesticide use as well. Apparently, the farmers recognized that pests are of great concern and that pesticide use was becoming more expensive. These concerns coupled with lack of adequate quality control on the pesticides sold in the market were among their perceived direct constraints.

### ***Priority topics of IPM information/guidance needs of farmers***

The farmers recognized the specific topics of IPM information they needed, based on the constraints they experienced. These needs included aspects of crop production as well as protection (figure 7). While crop management technologies appeared to be their priority, three major areas relating to crop protection (appropriate pesticides, correct method and dose of

application as well as capacity for correct identification of pests) were apparently next in priority. Such a listing of their IPM information needs is helpful in suitably planning to cater to the farmers' perceived IPM information priorities.

## **Current and Potential IPM Awareness-Building Initiatives for Farmers**

Increased access to supplementary irrigation has encouraged multitudes of smallholder farmers in eastern Africa to take up production of vegetables for urban and export markets since the potential for income generation is attractive. In Kenya alone, over 300,000 farm families produce vegetables for export as outgrowers (Ouko 1997). However, the range of information required by them on different aspects related to pest management, such as safe and selective use of pesticides, pesticide residues and waiting periods, needs-based pesticide use as well as alternative methods to substitute for pesticide use, calls for substantial strengthening of the local research-extension-farmer information flow systems. Based on earlier experience and consultation with stakeholders (Sithanatham et al. 1998a), a network program has been initiated under ICIPE's leadership with NARES (National Agricultural Research and Extension System) partners in four countries in Eastern Africa—Kenya, Ethiopia, Tanzania and Uganda—for promoting pest-management awareness and attitudes among smallholder farmers growing income-generating vegetable crops (Sithanatham et al. 1998b).

The features being tested for developing locally sustainable pest-management information flow models include:

- group learning and exchange of experiences in pest management within and between farmer groups
- promoting farmers' own cadre of trainers as "second-line extensionists"
- appropriate local modifications in FFS approach

The program involves baseline studies of farmer-groups' needs and priorities in information on pest management. Stakeholder-participatory assessment of the scope of different pest-control options is also being undertaken. Preseason training to frontline extensionists and farmers' cadre trainers (second-line extensionists) is being structured to cater to the following themes in successive seasons:

- capacity to correctly identify the common pests and distinguish them from beneficial insects like predators, parasitoids and pollinators
- awareness of safe and selective use of pesticides as well as standards for residues and consumer safety
- alternative options (to pesticide use) and how to evaluate and/or adopt them

### ***Recent Initiatives in the Region by Different Institutions***

Some more IPM projects have been undertaken on irrigated crops in the region by organizations including ICIPE, FAO/CABI and GTZ/IPM. The FAO IPM projects on cotton

and vegetables in Sudan offer substantial practical experience in utilizing the FFS approach for IPM awareness-building among smallholder farmers in Africa.

Such initiatives may be visualized to help evolve locally sustainable models for empowering farmers with knowledge and confidence for adopting improved pest-management options as an integral part of the production of, and marketing strategies for, vegetable crops.

### ***Examples of Currently Recommended IPM Practices for Vegetables***

A list of currently recommended IPM practices is furnished below for the common vegetable crops grown in the region.

#### ***Tomato***

- certified disease-free seed
- seed treatment with a fungicide and an insecticide
- resistant/tolerant varieties to major diseases and to root-knot nematodes
- incorporation into the soil of neem cake powder for the control of root-knot nematodes
- staking, pruning, mulching and wider spacing where late blight is a problem
- *B.t.* products for control of bollworms
- mineral oils for control of red spider mites
- trap crops for nematodes and whiteflies

#### ***Cabbage/Kales***

- planting of varieties resistant to black rot
- certified disease-free seed (black rot)
- mulching and avoidance of overhead irrigation (black rot)
- *B.t.* products against DBM (do not use continuously)
- neem-based pesticides (DBM and aphids)
- intercropping with *cleome gynandra* or tomato (DBM)
- liming against club root disease of cabbage
- releases of *diadegma semiclausum* or *cotesia plutellae* where commercially available, for control of DBM

### ***French bean***

- seed treatment with imidacloprid + carboxin, oxycarboxin, captan or thiram for control of bean flies, aphids and damping-off diseases
- soil amendments for control of root rots
- incorporation of neem cake powder into the soil for the control of nematodes
- sprays of neem-based pesticides for the control of thrips
- use of bio-agents (*e.g., metarhizium anisopliae*) and bio-products (*e.g., spinosad*) for control of flower thrips
- avoidance of broad spectrum insecticides (to avoid killing of beneficial insects)
- use of mineral oils for control of red spider mites
- use of *B. t.* products for control of bollworms
- planting of varieties resistant/tolerant to rust

### ***General measures***

- crop rotation
- deep ploughing
- no mixed planting of young and old plants
- thorough weeding
- removal of crop debris from the field
- avoid field operations when wet
- do not plant new fields next to old crops
- mixed cropping

### ***Examples of Indigenous Practices and Materials Used in Pest Control***

Some of the practices and materials used by farmers for pest control in the region are listed below:

#### ***Local pesticides***

- kerosene-soap solution (helps get rid of aphids, mites and thrips)
- soap solution (a good remedy against aphids and thrips)

- cow urine (for control of aphids, mites, thrips and fungal foliar diseases)
- cow manure (similar to cow urine)
- cow milk (against virus diseases)
- sodium bicarbonate (control of powdery mildew)
- corn/simsim/sunflower oil (treating food grain against storage pests)

### ***Indigenous crop-protection measures***

- hand-picking of caterpillars
- releasing fowl into fields to feed on caterpillars
- burning of field after harvest
- flooding of fields
- mixed cropping/interplanting
- shift cultivation
- hand weeding
- use of own seed selected from robust plants
- soil amendments with farmyard manure
- use of ash against storage pests

## **Major Theme Areas Linked to IPM and Irrigated Agriculture**

### ***Interaction of Irrigation Methods and Regimes on Pest Severity and Management***

There is a need to undertake studies on the scope for beneficial options among irrigation methods and regimes that could minimize pest severity and consequently reduce pest-control costs. This research is crucial for promoting compatible and sustainable combinations of crop and water management. An example is the potential benefit of using sprinkler (wherever possible and if there are no other major drawbacks) so that pest severity could be reduced (e.g., aphids/caterpillars on kale/cabbage). Recent experiments in the Asian Vegetables Research and Development Center (AVRDC), Taiwan have shown the potential for utilizing irrigation regimes in minimizing the yield loss in onion due to thrips. There is a need to examine the direct and indirect effects of irrigation methods and intensities on crop health (pest and disease incidence levels), so that beneficial irrigation options could be adopted wherever possible. Mixing of pest-control products in irrigation water may also be given consideration, if it leads to a positive impact on pest control and/or ecosystem conservation.



### ***Assessment of Ecosystem Interactions in Irrigated Crop Production***

There is a need to relate the consequences and interactions of increased access to water as well as its efficient use in crop production with the agro-ecosystem components. For instance, flow irrigation with limited inundation (as in rice systems) can benefit by suppressing some pests like whitegrubs. However, furrow/channel irrigation passing through nematode-infested plots could inadvertently spread the problem. Access to irrigation is often associated with increased cropping intensity and fertilizer input. The extent to which the soil and habitat are intensively (often excessively) utilized and the impact of such crop-production practices on the sustainability of the ecosystem needs to be understood. Crops, which are common targets for a given pest, should be avoided in rotation, for example, the polyphagous pest—African bollworm (*Helicoverpa armigera*)—attacks tomato, capsicum, okra and French bean but does not attack some other vegetables like cabbage/kale and onion. Similarly, crops which cut off the buildup of soil nematodes (e.g., *Tagetes*, *Crotalaria*) should be encouraged as rotation crops in irrigated systems so as to promote soil health.

In irrigated crop production, there are perhaps three levels at which interactions between crop production practices and ecosystem components should be studied and, where necessary, harmonized. The first is at the level of choice of irrigation methods and/or regimes. While infrastructure and economic considerations may play a dominant role in their choice, options that benefit the ecosystem should be favored, wherever possible. On the other hand, the direct and indirect effect of the irrigation practices on the ecosystem components (at the multi-trophic level: soil-plant-pest-natural enemies) should be monitored and characterized. At the next level, whatever components/inputs go into the production (fertilizer, variety) and protection (preventive, curative) of the key target crops should also be studied for their effects on the other key components of the agro-ecosystem. At the final level, there is a need to consider individual farms in association with neighboring farms, so as to relate to the dynamics of the pestiferous as well as beneficial taxa both spatially and temporally. It is important that a multidisciplinary team involving irrigation experts, agronomists, plant protection (IPM) specialists, socioeconomists and extensionists should, together, plan and direct these studies.

### ***Role of Policy Issues in IPM Implementation***

Extensive reviews of the scope for IPM in the African agriculture have been produced in recent years (Kiss and Meerman 1991; Berger 1994; Zethner et al. 1989; Zethner 1995). Yudelman et al. (1998) have provided a futuristic vision on IPM in the context of global food production. The policy aspects need a holistic analysis and should be linked with overall strategies for improving the motivation among farmers to adopt IPM. Supportive policies that provide incentives for adopting organic and safer alternatives to pesticides, including appropriate crop rotation for minimizing pest problems, need to be explored. There is a great need for sensitizing policy makers on the importance of promoting IPM and the focus should be on the following:

1. Since irrigated agriculture is mostly characterized by intensive land use and external inputs, there is a need for policy guidelines that ensure sustainable use of natural resources. This will be important for sustainable income generation through irrigated agriculture.

2. In Eastern Africa, there is a need to sensitize national governments so as to recognize and declare IPM as a policy theme towards sustainable agriculture, especially in irrigated farming systems.
3. There is a need for a policy to link research initiatives for crop/pest management with management of vectors and vector-borne diseases of cattle and humans. This will minimize the practice of resorting to ecologically incompatible pesticide-based interventions and will help wean the farmers away from the “pesticide treadmill.”
4. There is a need to link the IPM policy with the human resources and institutional capability as the cornerstone of integrated community of health systems covering people, livestock, crops and the environment.
5. The research-extension linkages need to be reinforced with complementary initiatives for development of a wider menu of IPM options for key pests as well as for effective awareness-building programs to take IPM to the grassroots level.

## **Case Study of the Mwea Irrigation Project**

### ***Survey of Pest Problems and Current Farmer Practices***

#### ***Issues addressed***

A survey was undertaken to understand the IPM practices and issues in irrigated agriculture in the Mwea division, Kirinyaga district, Kenya. From within the five sections of the Mwea irrigation scheme and adjacent villages 50 farmers were randomly selected. Rice and vegetable crop producers were interviewed using a pretested structured questionnaire on farmers' characteristics, (gender, education, etc.), type of farming systems (crops, land, tenure, etc.), pest management (knowledge of pests, diseases and associated problems), chemical pesticides and their use, knowledge of the nontarget effects of chemical pesticides and source of knowledge on pest management and indigenous pest/disease management practices. Data were analyzed using descriptive statistical procedures.

#### ***Characteristics of households and farming systems***

The interviewed farmers (n=50) comprised men (72%) and women (28%), the majority (58%) being freeholders outside the scheme, and the rest (42%) being farmers inside the rice scheme. The majority of the farmers (57%) attained primary-level education, some (23%) had secondary- or tertiary-school education, while the rest (20%) had no formal education. Two rice varieties, namely, Basmati and BW were grown. The most prevalent vegetable crops were tomato (22%), kales (23%), soybean (10%) and French bean (7%). All farmers in the scheme are members of the cooperative society while farmers outside the scheme had no formal association to link them.

### *Knowledge of pests, diseases and associated losses*

*Knowledge of names and symptoms.* There is a big gap between farmers' knowledge of pests and diseases in relation to their damage symptoms. For example, whereas 57 percent of the farmers identified pests by name, only 35 percent identified their damage symptoms. The most frequently mentioned insect pests included leaf miner (30%), aphids (35%) and red spider mites (11%). Among the limited proportion (36%) that cited crop diseases by name only some (15%) had knowledge of their symptoms. Important diseases cited included late blight (8%), damping off (11%), bacterial wilt (7%), root rots (5%) and leaf spots (9%). In general, the majority of farmers were not able to recognize the symptoms of damage caused by pests and diseases.

*Perceived losses due to pests and diseases.* The perceived extent of losses due to pests and diseases varied greatly by crop. The majority of farmers (49%) estimated the extent of loss at less than 1/3 while 41 percent and 10 percent put it at 1/3–2/3 and over 2/3, respectively (figure 1).

*Figure 1. Percentage of farmers estimating yield loss due to pests and diseases in different crops grown in Mwea, Kenya.*

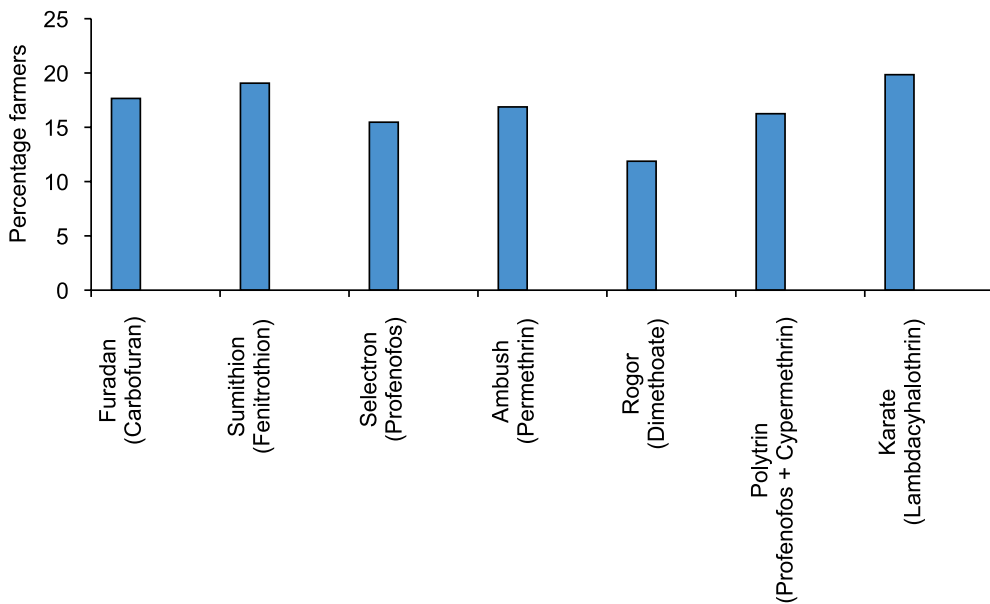

### *Chemical pesticide use*

The large majority of the farmers (92%) used pesticides to control pests and diseases. The common insecticides used for pest control in rice included Furadan (18%) and Supersumithion (19%), while those used for vegetable crops were Selecron (15%), Ambush (16%), Karate (20%), Dimethoate (12%) and Polytrin (16%) (figure 2). Fungicides commonly used were Dithane (54%) and Green copper (32%). Knowledge of the quantity of pesticides used varied considerably by crop and season. Most farmers (56%) indicated that insecticides are applied more often during the dry season than in the wet season. About one-third of the number of farmers (31%) observed that more fungicides were applied during the dry season when diseases were more prevalent. Most vegetable farmers (59%) indicated that, in the dry season, they sprayed pesticides on a weekly basis. On the other hand, the majority of the rice farmers (64%) sprayed only once and 37 percent sprayed twice or several times.

Figure 2. Commercial pesticides commonly used by farmers in Mwea, Kenya.

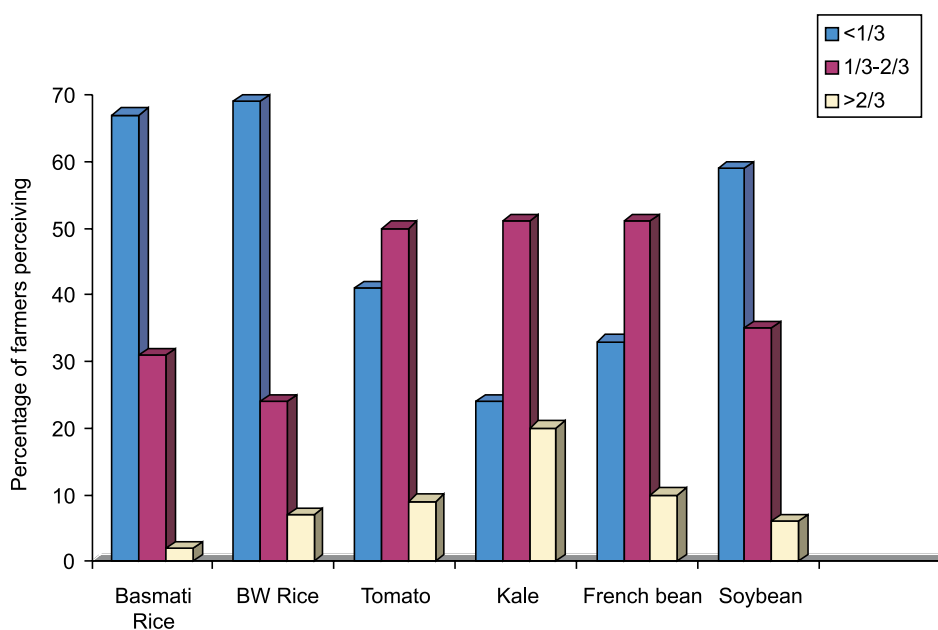

### *Knowledge of adverse effects of pesticides*

Farmers' knowledge of pesticide residues varied greatly by crops grown and farming systems practiced. On average, 37 percent of the vegetable farmers had knowledge of pesticide residues. Almost a third of the farmers (31%) were aware of the "waiting period" to be observed between pesticide application and crop harvesting. By contrast, none of the rice growers were aware of the waiting period. Most of the vegetable producers (58%) indicated that harvesting was done usually 3–7 days after spraying and the rest harvested after 7 days.

The farmer's knowledge of adverse effects of pesticides on beneficial insects appears to vary with the farming system and crops grown. The majority of the farmers outside the scheme (52%) and roughly one-fourth of the farmers in the scheme (26%) had knowledge of the adverse effects of pesticides on beneficial insects. Tomato farmers (63%) had the highest rate of awareness. The ratio was lowest (18%) for the Basmati rice growers. Among the commonly cited beneficial insects affected by pesticides were pollinators, i.e., bees (66%) and natural enemies such as the ladybird (22%). A large proportion of farmers (70%) specified that pesticides killed beneficial insects, rendered them inactive (9%), made them less reproductive (5%) and caused other effects (16%) (figure 3).

Figure 3. Percentage of farmers with knowledge of different effects of pesticides on beneficial

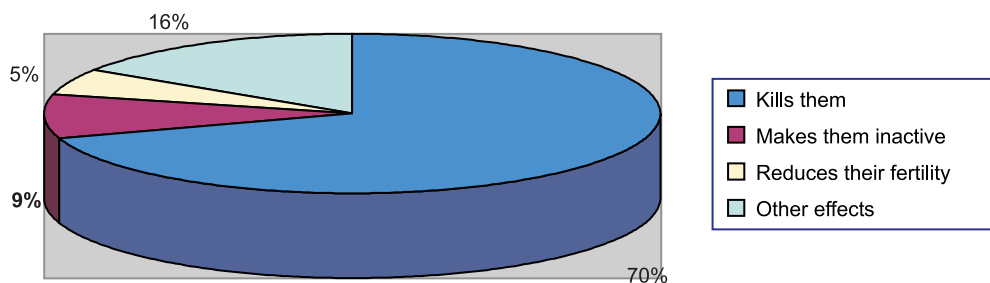

### ***Knowledge of pesticide resistance***

On average, 50 percent of the farmers had knowledge of pesticide resistance. Such knowledge was highest among tomato producers (77%), followed by kale growers (66%), French bean (60%) and other crops (40% or less). The pests that are resistant to pesticides, as commonly cited by farmers, were the red spider mite (32%), the leaf miner (15%), aphids (8%) and others (46%).

### ***Supply of pesticides***

Pesticides were supplied on credit to farmers in the irrigation schemes by their cooperative while outside farmers purchased them mainly from agro-vet stockists and brokers in the area.

### ***Source of information on pesticides use***

Information on pesticide use was obtained from local agro-vet stockists (26%), fellow farmers (19%), pesticide labels (22%) and extensionists (9%). On average, 67 percent of the farmers in the scheme had access to information on pesticide use while only 33 percent of the farmers outside the scheme had this information.

### *Farmers' own pesticide alternatives*

Several pesticide alternatives were being used for pest control to varying levels on vegetable crops and rice varieties. Some of the indigenous controls include the use of a mixture of tobacco and ash by farmers (8%) but their knowledge of the appropriate dosage of alternative controls was either inadequate or completely nonexistent. Furthermore, farmers' group discussions during the survey confirmed that they needed guidance on appropriate alternatives and the correct dosage for achieving effective control of major pests. Plant extracts, such as those from neem and tobacco, were not commonly used. Unlike pesticides, they have to be prepared before use, a task which some farmers found to be onerous, e.g., 17 percent of the farmers indicated that the preparation of concoctions was labor-intensive; 25 percent observed that since the most appropriate and effective application rates were unknown, they could not be depended upon for effective pest control; on the other hand, 10 percent of the farmers associated the use of concoctions with backwardness (figure 4).

*Figure 4. Percentage of farmers adopting indigenous pest control practices in Mwea, Kenya.*

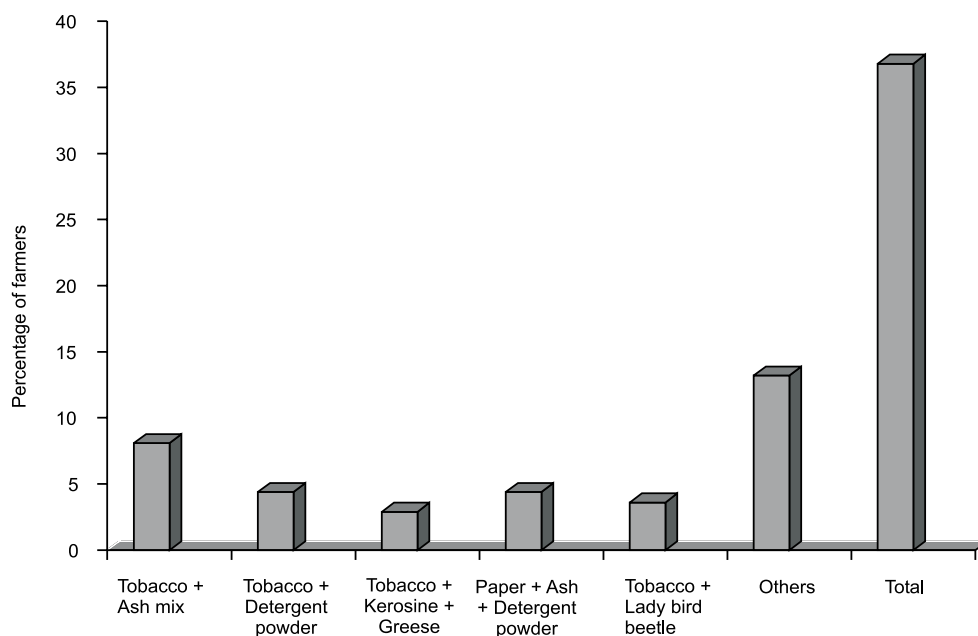

### ***Use of different pest-control practices***

An interesting feature was that the use of two or more pest-control components was higher among growers of vegetable crops than among growers of rice. The highest proportion of farmers adopting two or more components was among tomato producers (43%) followed by kale growers (18%) and the least among rice farmers (9% or less). For instance, 14 percent of the farmers combined pesticide controls with cultural practices while a mere 2 percent combined cultural practices with biological controls. Importantly, 43 percent of the farmers expressed disappointment at the increasingly declining pesticide effectiveness and because of this, they expressed a keenness to try other pest-control alternatives (figures 5 and 6).

### ***Concluding remarks***

The status of farmers' knowledge and the use of different pest-management practices were found to differ sharply between the two farming systems, i.e., between rice systems and vegetable/multi-cropping systems. Rice farmers appear to have limited experience in using pesticides since the agency staff handled the pest-control operations up to the end of 1999. The knowledge of pests, diseases and associated problems of these farmers was lower than that of the farmers in the open (non-scheme) multi-crop agricultural systems. It is also evident that scheme farmers grew mainly one crop, rice, which has fewer pest problems. The intensity of pest control in vegetable-growing systems is high and several chemical pesticides are in use. It appears that pesticide-application regimes and intensity are high especially during the dry season. Vegetable farmers appear to have a higher extent of knowledge of the adverse effects of pesticides than rice farmers. It is impressive to find that farmers are articulate on the harmful effects of pesticides on beneficial insects and other organisms. However, restricting the use of pesticides seems to be limited to export crops, apparently in response to strict regulations imposed by importing countries.

The use of indigenous pest-control practices seems to be constrained by several factors, such as laboriousness, lack of appropriate dosage recommendations and even prejudice against them. Supportive research is required to evaluate the efficacy and cost efficiency of these practices. What is more important is to create awareness among the farmers that they need to consider alternative approaches due to the reported declining effectiveness of chemical pesticides. Therefore, there is a window of opportunity for IPM.

### ***Farmers' Needs for IPM Adoption and Potential Awareness-Building Options***

#### ***Constraints***

Some of the factors constraining farmers' use of, and access to, IPM in irrigated agriculture in Mwea are listed below:

1. There is a lack of critical mass of human resources to plan and implement pest/vector/disease-management programs.
2. There is a lack of information on the IPM menu available to local extension workers, the private sector and farmers.

Figure 5. Percentage of farmers adopting some combination of different pest control practices in different crops in Mwea, Kenya.

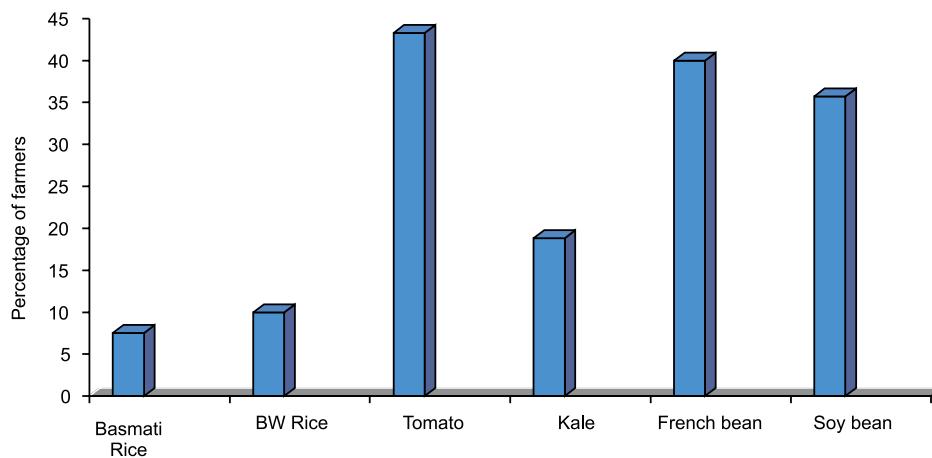
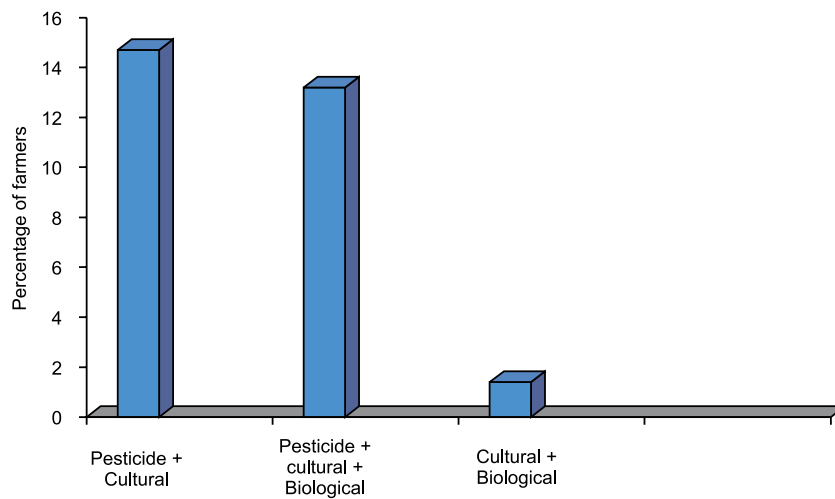

Figure 6. Percentage of farmers adopting different combinations of pest control practices in Mwea, Kenya.





3. Consumers have not motivated farmers to shift to the safe use of pesticides.
4. Indigenous pest/vector controls have not been evaluated for their efficacy, cost-efficiency and appropriate dosage.
5. IPM concepts and approaches have not been disseminated to the end users.
6. Lack of policy for promoting IPM in general and irrigated agriculture in particular.

### ***Suggestions***

To overcome the constraints listed above, two main suggestions are given below:

- The development of an IPM focus program to tackle pest/vector and diseases in line with the agro-ecological mold described earlier in this paper should be initiated for irrigated agriculture.
- Research results from Mwea show that there are several windows of opportunity for IPM. The starting point is the farmers' search for alternatives to chemical pesticides.

Information on the available improved IPM options/components should be made available to the farmers. The window of opportunity appears to be clear due to the high awareness level among farmers of the negative effects of chemical pesticides on beneficial insects. The finding that some consumers in the study area reject produce that appears to have chemical pesticide residues may be used as a basis to form catalytic consumer groups, which can lobby and exert pressure on farmers to use safe products in pest management.

### ***Conclusions and Themes for Future Focus***

#### ***Conclusions from assessing the present situation***

Irrigated agriculture, characterized by intensive land use and crop production, is largely leaning to substantial use of external inputs. Overlapping seasons of planting and year-round cultivation of crops, often lead to greater buildup of pests both above and below ground. This, in turn, leads to increased costs of pest control or greater yield loss due to pests. Irrigated vegetable crops tend to fetch attractive prices in the market if they are free of blemish. Farmers often resort to unilateral (and indiscriminate) pesticide use in their effort to maximize the proportion of blemish-free produce at harvest. In the process, they unwittingly get into the "pesticide treadmill," since the excessive use of pesticides often destroys the natural enemies of pests leading to a greater buildup of pests over time, even within the same crop season. Very often, enthusiastic farmers tend to "overuse" the "pesticide gun" and this results in a "U" turn, as the system cannot be sustained any longer. This situation presents both an urgent need and an excellent opportunity for utilizing IPM as the key for sustainable production of irrigated crops (figure 7). The scores of recent suicides by cotton farmers reported from India bring home the lesson for us in Africa, that IPM is important for sustainable crop production, and the guideline is "not to destroy the friends of farmers (beneficial insects)" in the ecosystem and not to favor unnatural buildup of pest organisms, while adopting different irrigation and pest-control practices.

Figure 7. Interlinkage of IPM with sustainable irrigated agriculture in sub-Saharan Africa.

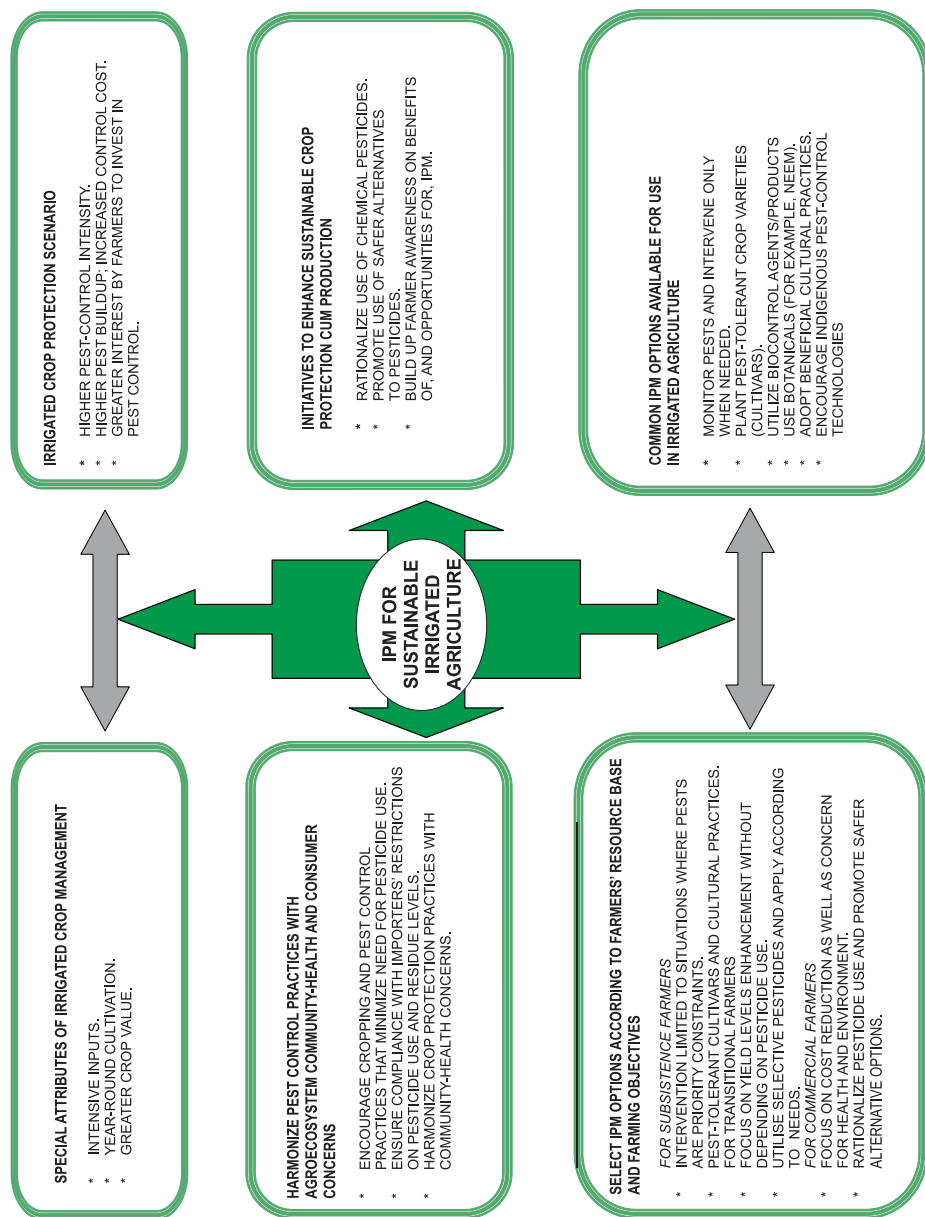

### ***Researchable themes of priority for sustainable irrigated crop production***

IPM offers good scope as a component of sustainable management of natural resources in irrigated agriculture. While most papers in this System-Wide Initiative on Irrigation Management (SWIM) document focus on management of water, as related to socioeconomic and infrastructural issues, this paper focuses on complementarities between water use and pest control on irrigated crops, with focus on sustainability of the agro-ecosystem. In this section, we list priority research themes that could promote improved pest management options towards minimizing the pesticide burden on the soil-water systems in irrigated agriculture.

#### ***Promoting irrigation methods and regimes that minimize the severity of pest problems on target crops***

Research on the effects of different irrigation methods and regimes on the extent of pest infestation in common target crops needs to be encouraged. This will help in advising agronomists/extensionists on the choice of options that can help minimize the intensity of pest-control interventions on irrigated crops.

#### ***Promoting the use of safer alternatives (IPM components) to chemical pesticides to minimize polluting the soil-water systems***

Applied and adaptive research and demonstration of environmentally friendly pest-control options for key pests should be supported. This will be important for motivating farmers to shift away from the indiscriminate use of chemical pesticides. Among other benefits of the IPM approach is the minimizing of the pesticide burden on the soil-water system.

#### ***Developing holistic IPM-ICM-IAM impact assessment methodologies relevant to irrigated agricultural ecosystems***

The multi-trophic impact of IPM and Integrated Crop Management (ICM) on linking soil-water-plant and beneficial or pestiferous flora/fauna should be more holistically evaluated/demonstrated in farming systems, based on irrigated agriculture. Improvements in methodologies and efforts to identify benchmark sites representing predominant irrigation systems for such research should be considered.

#### ***Integrating IPM with the management of cattle- and human-disease vectors***

The indirect effects of IPM on the development of pesticide resistance among cattle-disease vectors (e.g., tsetse flies) and human-disease vectors (e.g., mosquitoes) in irrigation projects need to be monitored. The positive effect of IPM adoption in reducing the pesticide burden on the nontarget vector insects (in terms of resistance buildup) and on the soil-water system (in terms of pollution) should be verified and suitably demonstrated.

#### ***Recommendations for Regional Initiatives***

Having recognized the critical role of the IPM approach to the sustainability of irrigated farming systems in the region, the following recommendations are made towards utilizing IPM research and knowledge on a continuing basis in irrigation project areas. These recommendations may be considered in the context of strengthening overall impacts in the region.

- i. Build up and update a readily accessible “knowledge base” on important pest/disease constraints and the available/improved options for their management.
- ii. Support “complementary” and “gap-filling” research that would help reduce the severity of pests, especially through “preventive” strategies.
- iii. Encourage “adaptive” and “participatory” research towards minimizing the use of chemical pesticides by substituting safer alternatives for them.
- iv. Monitor (and demonstrate) the benefits (both economic and environmental) of adopting IPM approach as a component of ICM in agro-ecosystem sustainability.
- v. Provide “backup” and “underpinning” on the direct/indirect effects of irrigation methods and regimes on the pest severity and buildup in key crops.
- vi. Contribute to IPM capacity-building among national research/extension personnel as part of IPM-ICM approach for sustainable irrigated agriculture.

*Table 5. Topics of IPM-ICM information identified as priority needs by vegetable farmers in four countries in eastern Africa, 1998–1999.*

IPM Information Topics Needed	Number of Farmers Identifying the Need				
	Kenya (n=60)	Ethiopia (n=30)	Tanzania (n=50)	Uganda (n=60)	Overall (n=200)
Improved crop-management practices	35	2	24	29	90
Appropriate choice of pesticides	32	6	7	10	55
Correct identification of pests and their symptoms	28	4	7	13	53
Pesticide application method and dosage	17	12	1	13	43
Safe handling of pesticides	0	0	0	16	16
Improved supply of quality seeds	4	12	0	0	16
Dependable source of pesticides	0	12	1	2	15
Fertilizer application practices	5	1	1	1	8
Alternatives to chemical pesticides	3	1	1	1	6
Record keeping on pests and their control	1	0	0	2	3
Crop rotation practices	1	0	1	0	2

*Source:* ICIPE-IFAD-USAID-NARS IPM Project.

*Table 6. Impact assessment of IPM trainers' training in Kenya and Uganda (Farmers' cadre and extensionists, 1988–1999).\**

Aspects Related to IPM	Percentage of Trainers with Awareness			
	Uganda		Kenya	
	Pre-training	Post-training	Pre-training	Post-training
Knowledge of pests (insects, disease and weeds)	58	92	100	100
Knowledge of pest damage symptoms	42	67	92	92
Knowledge of pest life cycle	33	50	83	92
Knowledge of pre-harvest waiting periods	50	67	54	61
Knowledge on safety use of pesticides	58	67	92	100
Knowledge of safer pest control methods	42	58	62	92
Knowledge of beneficial insects	50	50.0	62	100

\*Source: ICIPE-IFAD-USAID-NARS IPM Project.

## Literature Cited

- Bariola, L. A.; T. J. Henneberry; V. T. Walhood; and C. Brown. 1984. Pink bollworm: Effects of early maturing, narrow row cotton, insecticides, and chemical termination on seasonal infestations and overwintering larvae. *Southwestern Entomologist* 9(1): 62–68.
- Berger, A. 1994. *Using natural pesticides: Current and future perspectives*. Uppsala, Sweden: SUAS. 37pp.
- Bhanot, J. P.; and A. N. Verma. 1990. Effect of different levels of irrigation and fertilizers on termite damage and yield of barley crop. *Indian Journal of Ecology* 17(1): 86–89.
- Bieri, M.; F. Zwygart ; G. Tognina; and G. Stadler. 1989. The importance of soil water content for the biological control of *Thrips tabaci* Lind. on cucumbers in the greenhouse. *Mitteilungen der Schweizerischen Entomologischen Gesellschaft* 62(1): 2–28.
- Cabanillas, H. E.; and J. R. Raulston. 1996. Effects of furrow irrigation on the distribution and infectivity of *Steinernema riobravii* against corn earworm in corn. *Fundamental and Applied Nematology* 19(3): 273–281.
- Café Filho, A. C.; and J. M. Duniway. 1996. Effect of location of drip irrigation emitters and position of *Phytophthora capsica* infections in roots on *Phytophthora* root rot of pepper. *Phytopathology* 86(12): 1364–1369.
- Chandra, A.; Bhati, D. P. S.; and K. M. Singh. 1989. Note on the effect of soil raking and irrigation on survival and hatching of eggs of mango mealybugs, *Drosicha mangiferae* Green. *Current Agriculture* 13(1–2): 103–104.
- Davis, R. F.; F. D. Smith; T. B. Brenneman; and H. Mclean. 1996. Effect of irrigation on expression of stem rot of peanut and comparison of above ground and below ground disease ratings. *Plant Disease* 80(10): 1155–1159.
- Derron, J. O. 1988. Crop rotation: An important component of integrated pest management. *Schweizerische Land Wirtschaftliche Forschung* 27(1): 91–101.
- El-Sherif, S. I.; and N. A. A. Badr. 1992. Laboratory and field investigation on the effect of submersion on the pupae of the cotton leaf-worm, *Spodoptera littoralis* (Boisd.) (Lepidoptera: Noctuidae). *Arab Journal of Plant Protection* 10(2): 239–245.
- Falcon, L. A. 1985. Development and use of microbial insecticides. *Biological Control in Agriculture IPM Systems* 229–242.
- Fernandez, S. 1997. Effect of two cultural practices on populations of insect pests affecting potato tubers (*Solanum tuberosum* L.). *Revista de la Facultad de Agronomia Universidad del Zulia* 14(6): 603–610.
- Flint, H. M.; S. E. Naranjo; J. E. Leggett; and T. J. Henneberry. 1996. Cotton water stress, arthropod dynamics and management of *Bemisia tabaci* (Homoptera: Aleyrodidae). *Journal of Economic Entomology* 89(5): 1288–1300.
- Forrester, N. W.; and H. Saini. 1982. Effect of moisture stress on damage to sunflowers by Rutherglen bug (*Nysius vinitor*). In *Proceedings, 10<sup>th</sup> International Sunflower Conference*, 130–132.

- Geddes, A. M. W. 1990. The relative importance of crop pests in sub-Saharan Africa. Kent, UK: NRI, 68pp.
- Gopalan, M.; N. Coumararaja; and G. Balasubramanian. 1987. Effect of different planting dates and irrigation regimes on the incidence of rice mealybug, *Brevinnia irch* Lindinger. *Madras Agricultural Journal* 74 (4/5): 226–227.
- Hamburg, H. Van; and P.J. Guest. 1997. The impact of insecticides on beneficial arthropods in cotton agroecosystems in South Africa. *Archives of Environmental Conservation and Toxicology* 32(1): 63–68.
- Heong, K. L.; and M. M. Escalada. 1997. Perception change in rice pest management: A case study of farmer's evaluation of conflict information. *Journal of Applied Communications* 81(2): 3–17.
- Hull, L. A.; and E. H. Beers. 1985. Ecological selectivity. Modifying chemical control practices to preserve natural enemies. *Biological Control in Agricultural IPM systems* 103–122.
- Ioannidis, P. M. 1996. The effect of the root aphid, *Pemphigus fuscicornis* Koch. on sugar beet. *Congres Institut International de Recherches Betteravieres, Palais des Congres, Bruxelles, Belgium* 13(17): 269–276.
- Jiang, H.; J. Fry; and N. Tisserat. 1998. Assessing irrigation management for its effects on disease and weed levels in perennial rye grass. *Crop Science* 38(2): 440–445.
- Kiss, A.; and F. Meerman. 1991. Integrated pest management and African agriculture. *World Bank Technical Paper Number* 142 pp.
- Knight, A. L. 1998. Management of codling moth (Lepidoptera: Tortricidae) in apple with overhead watering. *Journal of Economic Entomology* 91(1): 209–216.
- Knight, T. L.; R. J. Martin; and I. C. Harvey. 1989. Management factors affecting lentil production in mid-Canterbury. In *Proceedings of Annual Conference of Agronomy Society of New Zealand* 19 : 17–24.
- Kogan, M.; and L. D. Lattin. 1993. *Biodiversity and Conservation* 2(3): 242–257.
- Kusneniwar, P. N.; and A. D. Deshpande. 1991. Effects of different levels of irrigation on the incidence of the leaf miner on summer groundnut. *Journal of Maharashtra Agricultural Universities* 16(3): 454.
- Lambert, L.; and L. G. Heatherly. 1995. Influence of irrigation on susceptibility of selected soybean genotypes to soybean looper. *Crop Science* 35(6): 1657–1660.
- Latimer, J. G.; and R. D. Oetting. 1994. Brushing reduces thrips and aphid populations on some greenhouse-grown vegetable transplants. *Hort Science* 29(11): 1279–1281.
- Lewis, W. J.; and D. A. Nordlund. 1985. Behaviour modifying chemicals to enhance natural enemy effectiveness. *Biological Control in Agricultural IPM Systems* 89–101.
- Maykuss, F. 1989. Plant protection in irrigated potato. *Kartoffelbau* 40(5): 168–170.
- Mengech, A. N.; N. Kailash; and R. Saxena. 1995. *Integrated pest management in the tropics: Current status and future prospects*. New York, John Wiley and Sons: UNEP and ICIPE.

- Mesbah, H.A.; H. K. El-Sherif; A. A. Gaber; and H. K. E. L. Sherif. 1985. The common harmful pests found on sugar beet plants in Alexandria region. 2 - Effect of irrigation regime and nitrogen levels on the infestation of *Pegomijia hyoscyami* curtis and *Scrobipalpa ocellatella* Boyd; the common sugar beet insect pests at Alexandria region. *Annals of Agricultural Science* 23(1): 365–372.
- Milevoj, L.; and J. Osvald. 1994. The effects of drip irrigation on the occurrence of downy mildew of cucumber (*Pseudoperonospora cubensis* ([Berk et curt.] Rostow) [in field culture]. *Mededelingen Faculteit Landbouwkundige en Toegepaste Biologische Wetenschappen Universiteit Gent* 59(3a): 853–858.
- Montgomery, D. 1983. When local participation helps. *Journal of Policy Analysis and Management* 3(1): 90–105.
- Moris, J. R.; and D. J. Thom. 1987. Introduction. In *African irrigation overview (main report)*. Africa USAID: Water management synthesis 11. Project WMS report 37, p. 144, ed. J. R. Moris and D. J. Thom.
- Mrig, K. K.; J. P. Chaudhary; and J. C. Mahla. 1995. Effect of irrigation intervals on the incidence of shoot and root borers in sugarcane ratoon. *Journal of Insect Science* 8(2): 188–199.
- Mullin, C. A.; and B. A. Croft. 1985. An update on development of selective pesticides favouring arthropod natural enemies. *Biological Control in Agricultural IPM Systems* 123–150.
- NRI (Natural Resources Institute). 1992. *A synopsis of integrated pest management in developing countries in the tropics*. Kent, UK: NRI. 20pp.
- Nwanze, K. F.; Y. V. R. Reddy; F. E. Nwilene; P. Soman; K. B. Laryea; and R. Jayachandran. 1996. Reduction of shoot fly damage in irrigated post-rainy season sorghum by manipulating irrigation. *Annals of Applied Biology* 129(3): 391–403.
- Obrycki, J. J.; and T. J. Kring. 1998. Predaceous coccinellidae in biological control. *Annual Review of Entomology* 43: 295–321.
- Ogutu, W.; S. Sithanatham; B. Atonya; and M. Waiganjo. 1998. Developing need-based training for farmer trainers in improved pest management on vegetable crops: Recent ICIPE-NARS partnership in Kenya. In *Proceedings of Biennial Conference of African Association of Insect Scientists*, 23 July 1998, Ouagadougou, Burkina Faso: AAIS (abstract).
- Ouko, J. O. 1997. Export horticulture in Kenya: An independence with pest management. Paper presented at the stakeholders meeting on Improved Pest Management for export vegetables in Kenya: An assessment of needs, potentials and priorities. 26–27 February 1997, ICIPE, Kenya.
- Parsana, G. J.; D. D. Malavia; and D. J. Koshiya. 1994. Effect of drip irrigation on incidence of insect pest of sugarcane. *Gujarat Agricultural University Research Journal* 20(1): 15– 17.
- Perfect, T. J. 1986. Irrigation as a factor influencing the management of agricultural pests. *Scientific Aspects of Irrigation Schemes* 347–353.
- Prasad, D.; K. M. Singh; R. N. Katiyar; and R. N. Singh. 1987. Influence of irrigation on the crop growth, pest incidence and crop yield of pea, *Pisum sativum* Linn. *Indian Journal of Entomology* 49(3): 330–344.
- Saly, A.; Z. Vargova; and J. Barokova. 1984. The effect of irrigation upon free-living nematodes in sugar beet soil treated with herbicides. *Biologia Czechoslovakia* 39(6): 573–582.



- Singh, Inderjeet; K. S. Brar; T. S. Ahuja; and I. Singh I. 1994. Effect of irrigation on the incidence of mustard aphid, *Lipaphis erysimi* (Kalt). *Indian Journal of Entomology* 56(1): 63–66.
- Singla, M. L.; and M. S. Duhra. 1990. Effect of seed rate and irrigation interval on the incidence of top borer and shoot borer in sugarcane. *Journal of Insect Science* 3(2): 189–191.
- Sithanantham, S.; K. A. Nyarko; W. Ogutu; L. Chongoti; G. N. Kibata; J. O. Ouko; C. Mukindia; S. G. Agong; A. A. Seif; and B. Loehr. 1998a. Stakeholder consultation towards initiatives for improved pest management in export vegetables in Kenya, 258–267. In *Proceedings of the 2<sup>nd</sup> Biennial Crop Protection Conference*. Kenya: Crop Protection Research in Kenya, KARI-ODA.
- Sithanantham, S.; W. Ogutu; B. Atonya; C. Mukindia; and J. O. Ouko. 1998c. Farmer participatory initiative for awareness building on improved pest management in export vegetables among smallholder farmers in Nguruman area of Kajiado district, Kenya. In *Proceedings of the 2<sup>nd</sup> Biennial Crop Protection Conference*, 245–257. Kenya: Crop Protection Research in Kenya; KARI-ODA.
- Sithanantham, S.; M. M. Waiganjo; C. Ssekyewa; C. Akemo; I. Swai; and A. Gashawbeza. 1998b. Towards improved information dissemination on integrated pest management among smallholder vegetable farmers: An ICIPE-NARES network initiative in Eastern Africa. Pages 2–3. In *Proceedings of African Association of Insect Scientists Meeting*, 19–23 July 1998, Ouagadougou, Burkina Faso (abstract).
- Sithanantham, S.; M. Waiganjo; C. Akemo; C. Ssekyewa; I. Swai; A. Gashawbeza; Y. Mohamed; J. Kibaki; S. B. Wepukhulu; and C. M. Matoka. 2000. Surveys of practices and perceptions of smallholder farmers relating to pest management on vegetable crops in Eastern Africa. *Proceedings of the International Congress of Entomology*. Foz do Iguassu, Brazil 20–26 August 2000 (abstract).
- Stoner, K. A. 1993. Effects of straw and leaf mulches and trickle irrigation on the abundance of Colorado potato beetles (Coleoptera: Chrysomelidae) on potato in Connecticut. *Journal of Entomological Science* 28(4): 393–403.
- Talekar, N. S.; S. T. Lee; and S. W. Huang. 1986. Intercropping and modification of irrigation method for the control of diamondback moth. Diamondback moth management. In *Proceedings of the First International Workshop* 145–151.
- Tiffen, M. 1987. Land Issues. In *African irrigation overview (main report)*. Africa USAID: Water management synthesis, 329–359, ed. J. R. Moris and D. J. Thom. *Project WMS Report 37*.
- Van Hamburg, H.; and P. J. Guest. 1997. The impact of insecticides on beneficial arthropods in cotton agro-ecosystems in South Africa. *Archives of Environmental Contamination and Toxicology* 32(1): 63–68.
- Waiganjo, M. M.; S. Sithanantham; and M. Waithaka. 1998. Survey of perceptions, attitudes and knowledge status of smallholder vegetable farmers relating to pests and their management in Thika, Kenya. *Proceedings of African Association of Insect Scientists Meeting*. p. 3. 19–23 July 1998, Ouagadougou, Burkina Faso (abstract).
- Wheatley, A. R. D.; J. A. Wightman; J. H. Williams; and S. J. Wheatley. 1989. The influence of drought stress on the distribution of insects on four groundnut genotypes grown near Hyderabad, India. *Bulletin of Entomological Research* 79(4): 567–577.

- Wilding, N.; S. K. Mardell; and P. J. Brobyn. 1986. Introducing *Erynia neoaphidis* into a field population of *Aphis fabae*; form of the inoculum and effect of irrigation. *Annals of Applied Biology* 108(2): 373–385.
- Yan, W. X.; C. H. Jiang; and D. Xiang. 1981. Discussion on the occurrence and forecasting of *Chlorops oryzae* Matsumura. *Insect knowledge Kunchong zhishi* 18(5): 197–199.
- Yudelman M.; A. Ratta; and D. Nygaard. 1998. *Pest management and food production: Looking to the future*. Washington, D. C.: IFPRI. 53pp.
- Zethner, O. 1995. Practice of integrated pest management in tropical and subtropical Africa: An overview of the decades (1970-1990). In *Integrated pest management in the tropics: Current status and Future prospects*, 1–13, ed. A. N. Mengech, K. N. Saxena, and H. N. B. Gopalan. John Wiley and Sons.
- Zethner, O.; A. N. Mengech; K. N. Saxena; and H. N. B. Gopalan. 1989. *Pest management and the African farmer*. Nairobi: ICIPE/WorldBank. ICIPE Science Press.



## Part 4

### Potential Impacts of Changes in Smallholder Irrigation



# Commercialization of Smallholder Irrigation: Economic and Social Implications in Semiarid Areas of Eastern Kenya

H. Ade Freeman and Said S. Silim<sup>1</sup>

## Introduction

The observed increase in smallholder commercial irrigation and adoption of new irrigation technologies in Kenya provide new opportunities for increasing agricultural productivity and incomes especially in semiarid areas. Irrigation can lead to a reduction in crop-production risk and, therefore, provides greater incentives to increase input use, increase crop yields, intensify crop production and diversify into higher-valued crops. The resulting increase in marketable surplus and commercial activities has the potential to generate increased incomes for farmers. Yet as smallholder commercial irrigation expands, issues relating to access to water among competing user groups, enterprise profitability and access to markets take on added importance because they directly impact on the size and distribution of benefits accruing to various stakeholders.

Data were collected from secondary sources and key informants in the Makueni and Central Meru districts of eastern Kenya. Rapid market surveys using a checklist were conducted to fill in gaps in data. The results from the study are used to draw implications for likely economic and social impacts from the growth of smallholder commercial irrigation.

## Biophysical and Socioeconomic Profile of the Study Area

Makueni and Central Meru districts have a total area of 10,4520 square kilometers and an estimated population of 1.3 million (table 1). Both of these districts are characterized as arid and semiarid agro-ecological zones but with varying potential for agricultural production. These districts have a bimodal rainfall pattern with the first season known as the long rains falling between March and May and the second season known as the short rains falling between October and December. The average annual rainfall in both seasons varies from 500 mm to 2,600 mm in Meru Central and slightly over 1,000 mm in Makueni.

Agriculture, including livestock, is a major economic activity in the study areas with a predominance of smallholder farms. In the Makueni district, crop production contributes only 9 percent of the total agricultural income of Ksh1.3 billion. On the other hand, income from crop production accounts for 76 percent of an estimated total agricultural income of Ksh1.8 billion in the Meru Central district.

A similar proportion of land is classified as cultivable land in Makueni and Meru Central. However, the irrigated area of 1,866 hectares in Makueni represented 0.3 percent of the cultivable area while in Meru Central the irrigated area of 4,078 hectares represented 2 percent

---

<sup>1</sup>ICRISAT, P.O. Box 39063, Nairobi, Kenya.

Table 1. Area and population in the study area.

District	Total Area (km <sup>2</sup> )	Cultivable Area (ha)	Proportion of Cultivable Land in Total Area (%)	Total Population (‘000)	Population Density (Persons/km <sup>2</sup> )
Makueni	7,440	554,000	74	767	103
Meru Central	3,012	216,500	72	500	166

Sources: Ministry of Agriculture, Central Bureau of Statistics.

of the total cultivable area. This relatively low proportion of irrigated areas in both districts implies that rain-fed agriculture is predominant in these areas.

The production of horticultural crops is an important economic activity in the Makueni and Meru Central districts. Although accurate estimates were not available at the time of our survey, anecdotal evidence suggested that smallholder farmers produced most of these crops. The area under horticultural crops in the Makueni district was estimated at 277 hectares in 1998. The total production was estimated at 5,572 metric tons of which vegetables accounted for 5,268 metric tons and fruits for 304 metric tons. Production of vegetables declined by 25 percent and fruit production by 86 percent between 1996 and 1998. In Meru Central an estimated 2,009 hectares were under horticultural crops in 1998. This represented a 69-percent increase over the acreage under horticultural crops in 1991. Production data show that 21,592 metric tons of horticultural crops were produced in 1998, a 174-percent increase over the total production in 1991 (table 2). Thus smallholder production of horticultural crops appears to be declining in the Makueni district and increasing in Meru Central.

Table 2a. Trend in production of horticultural crops in Makueni, 1996–1998 (output in metric tons).

	1996	1997	1998
<i>Vegetables</i>			
Brinjal	3,200	4,050	1,800
Chili	-	225	120
Okra	1,485	900	560
Karella	315	1,000	396
Tomato	1,800	2,000	1,400
Kale	144	720	800
Onion	90	240	192
<i>Fruits</i>			
Mango	120	-	42
Pawpaw	1,200	300	210
Custard apple	60	12	12
Citrus	850	120	40

Sources: MoA 1999a.

Table 2b. Trend in area planted to horticultural crops in Meru Central, 1991–1998.

Crop	Area (ha)							
	1991	1992	1993	1994	1995	1996	1997	1998
Cabbage	325	250	271	519	400	360	420	440
Tomato	204	212	112	284	300	380	400	430
Kale	158	138	112	139	123	75	70	85
Onion	45	35	159	254	200	240	260	280
Karella	-	-	50	78	87	50	62	70
Brinjal	-	-	70	54	37	33	40	52
Snowpea	-	-	100	150	180	280	-	-
Fr. bean	390	400	705	600	400	350	390	410
Okra	-	-	60	60	43	50	44	50
Dudhi	-	-	11	15	18	15	29	32
Valore	-	-	178	15	12	20	-	-
Carrot	74	70	92	86	109	90	130	160

Source: MoA 1999a.

Table 2c. Trend in production of horticultural crops in Meru Central, 1991–1998 (output in metric tons).

	1991	1992	1993	1994	1995	1996	1997	1998
Cabbage	3,365	2,445	1,626	5,190	4,000	3,600	6,300	6,600
Tomato	1,164	1,300	1,680	1,988	2,400	3,420	4,000	5,160
Kale	854	754	224	278	264	300	210	340
Onion	334	245	636	1,270	1,600	3,600	3,900	4,200
Karella	-	-	198	287	609	400	558	700
Brinjal	-	-	214	366	296	264	360	468
Snowpea	-	-	30	56	360	980	-	-
Fr. bean	1,720	1,420	2,999	3,160	800	1,050	1,170	1,640
Okra	-	-	240	516	365	450	396	500
Dudhi	-	-	45	54	162	150	319	384
Valore	-	-	714	76	48	100	-	-
Carrot	444	440	368	344	545	720	1,300	1,600

Source: MoA 1999b.

The nutritional status of children and the percentage of the population with access to safe drinking water are important indicators of the welfare or general well-being of the population.

Table 3 shows that large proportions of the population in the Makueni and Meru Central districts can be classified as living in poverty. This implies that interventions, which promoted improved economic opportunities in these areas, could offer significant prospects for raising the poor out of poverty.



Table 3. Selected welfare indicators.

Province/District	Children	Population
	Chronically Undernourished	with Access to Safe Water
Eastern Province	39	35
Makueni	50	17
Meru Central	38	63

Source: Central Bureau of Statistics 1994.

## Trends in Demand for Smallholder Irrigation

Irrigation in the Kibwezi division started in the 1950s with 100 acres (40 hectares) under the Kwa Kyai irrigation scheme. Small pockets of farmers in the division also used bucket kits to irrigate kitchen gardens outside the scheme. Since then smallholder irrigation has evolved involving irrigation groups and individual owners cultivating food crops, horticultural crops and other high-valued vegetables and fruits for domestic and export markets. The Kwa Kyai irrigation scheme was extended under the Makueni Smallholder Irrigation Program to 200 acres (80 hectares) in 1993. Data available indicate that the record of the number of smallholder farmers involved in smallholder irrigation has not been updated since 1993 at which time it was estimated that there were 13 irrigation groups and 133 individual irrigators in the Kibwezi division of the Makueni district. Our rapid survey estimated 4 smallholder irrigation schemes and 22 irrigation groups. We could not accurately estimate the number of individual irrigators but anecdotal evidence from farmers suggested that their numbers have increased since 1993.

Irrigation in Meru Central started in the 1930s during the colonial period. It took an upward trend in the 1980s with the implementation of the Mitunguu irrigation scheme in 1986. Smallholder farmers involved in this scheme produce mainly high-valued horticultural crops for export. Since the start of this scheme several individual- and group-based irrigation schemes have been developed. The most recent data available for Meru Central suggest that the number of irrigation projects increased from 131 in 1990 to the current estimate of 190 in 2000, a 45-percent increase in 10 years. These values however underestimated the growth of smallholder irrigation because many new projects were not recorded (personal communication, District Irrigation Engineer).

## Production Systems

### *Sources of Irrigation Water*

In the Kibwezi division of the Makueni district, irrigation activities are concentrated along Kibwezi, Athi and Thange rivers. In Meru Central irrigation activities are concentrated along the main rivers originating from Mount Kenya, Kathita, Kithino, Thigithu and Mutunga rivers, and their tributaries.

### ***Crops Grown under Irrigation***

Smallholder farmers irrigate a wide range of high-valued horticultural crops, mainly vegetables and fruits year-round, for sale in domestic and export markets. Farmers rarely irrigate food crops but a few irrigate maize and napier grass for livestock feed. A wide range of high-valued horticultural crops are grown including Asian vegetables (brinjal, ravaya, chili, okra, karella, guar, dudhi, turia, curry leaves, patra and saragua); vegetables for the domestic and export market (tomato, kale, onion, spinach, baby corn); and fruits (mango, pawpaw, custard apple and citrus).

### ***Organization of Irrigated Production***

There are variations in the organization of irrigated agriculture in the two sites. In the Makueni district, individual farmers generally use their own motorized pumps on their plots. These farmers make their own decisions on when to irrigate and are not affected by water rationing and management problems that those in the group-based schemes face. However, they are constrained by a lack of investment capital, high maintenance costs and low bargaining power in marketing. Though required by the Water Act (Chap. 372 of Laws of Kenya) few individual irrigators obtain water permits as a result of weak enforcement by authorities and bureaucracy involved in getting permits.

The group-based irrigators pool their resources by collective ownership of motorized pump sets and communal production. The groups are allocated water at different schedules. They tend to benefit from pooling their resources, but frequently face problems of management and limited water availability for group members at the lower end of the canal. Some farmers in irrigation schemes, mostly along the Kibwezi river, grow crops independently on their own plots but are members of groups that control the water supply. A water-management committee allocates water according to a water-allocation timetable. Most farmers in group-based schemes obtain water permits because many donors stipulate obtaining of permits as a requirement.

In the Meru Central district, group-based irrigation was dominant but few individuals own irrigation equipment. These group-based schemes are mostly donor-driven as some donors require the formation of groups as a prerequisite for funding. Many of these schemes operate on a cost-sharing basis with donor funds provided for the initial investment to establish water intake pipes and storage tanks. The farmers generally manage these groups by appointing a committee to manage the project while the farmers themselves enforce bylaws. Few individual farmers, mostly large-scale producers, use their own motorized pumps on their plots.

### ***Irrigation Technology***

There were also differences in the types of irrigation technology used in the two districts. In the Makueni district, motorized pump-fed furrow irrigation was dominant but a few farmers along the Kibwezi river used gravity-fed furrow irrigation. The Super MoneyMaker manual treadle pump was introduced recently but it has not been widely adopted. A few large-scale farmers and institutional operators such as the University of Nairobi and Tana and Athi River Development Authority use drip and sprinkler irrigation systems.

In the Meru Central district, sprinklers were dominant, due mostly to the nature of the topography. Furrow irrigation where water flows by gravity was another common irrigation technique. A few farmers used the bucket kit while some large-scale farmers used motorized pumps.

## Profitability of Horticultural Crop Production

The enterprise budget data in table 4 suggest that smallholder production of horticultural crops is a highly profitable enterprise when compared to alternative investment options that farmers can undertake in other crops. For example, gross margin for the most profitable enterprise is about 400 percent higher than that for the competing maize crop. This raises the question as to why every farmer in the area is not jumping on this bandwagon. Several reasons explain why the industry has not seen a massive entry into the sector as the profitability estimates would suggest. One important factor is that the enterprise budget values do not explicitly include transaction costs that are not explicitly measured. These costs arise mainly from the specific institutional arrangements that determine the production, market access and trade in horticultural crops. Because such costs are not included as monetary costs in the enterprise budget it is likely that these budgets erroneously overestimate the actual profitability of horticultural crop enterprises by underestimating the cost of inputs and overestimating the price of farm outputs. Consequently, the enterprise budget makes horticultural crop enterprises more profitable than they actually are, especially in the study areas where poor rural infrastructure, risk and other market imperfections lead to high transaction costs. These considerations need to be explicitly considered when designing technology interventions for farmers in these areas.

*Table 4. Gross margins of selected crop enterprises in the Makueni and Meru Central districts.*

Activity	Meru Central				Makueni	
	French bean	Tomato	Potato	Karella	Ravaya long	Brinjal
Land preparation	3,705	3,705	3,705	7,200	7,200	7,200
Seeds	29,640	741	29,640	0	0	0
Planting	2,470	7,410	2,964	2,012	1,817	1,817
Weeding	5,928	5,928	4,940	5,415	10,381	10,381
Manure	0	17,290	17,290	0	0	0
Fertilizer	8,892	11,115	13,338	3,735	3,960	3,960
Irrigation	0	0	0	32,230	25,300	25,300
Chemical	16,796	55,328	21,489	29,208	21,872	21,872
Nursery management	0	4,940	0	0	0	0
Pruning	0	1,976	0	0	0	0
Ridging	0	0	3,705	0	0	0
Fertilizer application	1,482	0	988	0	0	0
Spraying	2,470	2,470	7,410	0	0	0
Harvesting	39,520	6,175	14,820	5,425	12,472	12,472
Others	0	0	0	13,469	0	0
Miscellaneous costs 10%	0	0	0	9,869	14,048	14,048
Total variable cost (Ksh/ha)	110,903	117,078	120,289	108,563	97,050	97,050
Mean output (kg/ha)	9,880	24,700	19,760	12,500	20,000	20,000
Average price/kg	30	10	10	25	15	13
Total revenue	296,400	247,000	197,600	312,500	300,000	266,600
Gross margin (Ksh/ha)	185,497	129,922	77,311	203,937	202,950	169,550

Sources: MoA. 1999b; Kimenyi 2000.

## **Gender Issues**

Both male and female farmers were involved in production and marketing of horticultural crops. Women farmers however appeared to allocate more time to planting, weeding, harvesting, grading, sorting and retail trade. Men, on the other hand, allocated more time to land preparation and maintenance of irrigation systems. In some cases, there was joint decision making while in others men had full control over all production and marketing decisions.

## **Organization of Marketing**

Marketing arrangements were similar across both sites but marketing channels were different in domestic as opposed to export markets.

### ***Domestic Markets***

The main crops sold in domestic markets were cabbage, onion, kale, tomato and “export crops,” such as French bean, that were rejected by exporters because they did not meet export standards. Most farmers sold their crops at the farm gate to rural traders within the village or to traders who came from other districts to save time and to avoid transport costs from the farm to the market. Rural assemblers sold the produce to larger traders in local markets who, in turn, sold it to other traders in regional markets or large urban markets, such as Nairobi and Mombasa. Some traders entered into informal contracts with farmers before the crop was harvested. Rural traders collected and assembled small quantities of produce from many farmers scattered all over the rural areas. However, a few farmers, especially those who were located close to market centers, sold crops directly in local markets because they could get better prices. Crops were mostly packed in bags, except for tomato, that were packed in cartons and all transactions in local markets were in cash.

### ***Export***

The major crops sold in export markets were French bean, baby corn and Asian vegetables. There were several companies involved in marketing of export crops. In Meru Central it was estimated that the number of companies involved in marketing rose from 13 in 1997 to 20 in 1999, an increase of 54 percent in 2 years. Some of the exporting companies were seasonal, involved in crop marketing only during the peak season while others were engaged in marketing year-round.

There were several marketing arrangements for export crops:

- Exporting companies organized marketing directly with individual farmers or farmers’ cooperatives with written contracts specifying volumes, dates of collection and prices. This was a common practice with large-scale producers but few smallholder farmers had formal contracts with exporting companies or their agents.

- Company agents or brokers entered into verbal and informal contracts with groups of farmers. Penalties were agreed on in case of a breach of contract but without a written document it was difficult to enforce these penalties. Farmers were not restricted to sell to one agent but they invariably sold to agents who provided farm inputs such as seeds and chemicals.
- Company agents or brokers entered into verbal and informal contracts with individual farmers.
- Individual farmers sold their produce to company agents or brokers without a formal or informal contract. Transactions with informal contracts were usually on credit and it could take up to one month between collection of produce and payment.

Interlinked transactions are very common with company agents providing farmers with seeds, chemicals, advice on planting, application of chemicals, grading, sorting and packing. In some cases, technicians hired by the exporting company supervise farm activities from production to marketing and schedule planting through control over quantities of seed provided to avoid gluts in the market.

Farmers themselves usually harvest the crop. The produce is taken to collection centers where it is sorted and graded under the supervision of committee members. The produce is then packed in cartons provided by exporting companies, weighed and loaded into company vehicles. Members in the farmers' committee are also involved in weighing and recording of deliveries. Payment is by cash or check to the farmers' committee that then pays farmers after one or two weeks depending on the contractual agreements.

Farmers constructed the collection sheds. In some cases, collection sheds are rented. These sheds have rudimentary infrastructure and provide limited facilities. Further grading of the crop is done in company warehouses in Nairobi before export.

About 90 percent of the total horticultural export from Kenya is destined for European markets. In these markets, the European Union sets the grades and standards for exports including maximum pesticide residue levels, size, shape and weight of packaging materials.

## **Marketing Constraints at Smallholder Level**

Farmers face several marketing constraints. These include

- *Infrastructure:* Lack of physical infrastructure reflected in inaccessible roads, lack of market facilities, power and electricity.
- *Inputs:* Unavailability of quality seeds and other inputs including production and trading capital.
- *Post-harvest losses:* High levels of post-harvest losses.
- *Assembly cost:* Lack of economies of scale leading to high cost of assembly.

- *Quality of produce:* High levels of crops rejected at both farm level and at company warehouses because products did not meet market standards. In some cases, farmers were not compensated for rejected products.
- *Risk:* High levels of price and market uncertainty.
- *Market information:* Unreliable information on market trends or scheduling of production decisions to meet market needs. Farmers and other market intermediaries were not aware of important information on prices and marketing, grades and standard information further up the marketing chain.

## **Implications Arising from Commercialization of Smallholder Irrigation**

### ***Water Scarcity***

As smallholder irrigation expands in a regime of lack of enforcement of water regulation, lack of water pricing and uncontrolled water use, water scarcity is likely to be an overarching concern that could lead to social conflicts. What are the likely impacts of policy reforms given growing water-scarcity problems? What types of institutional innovations for allocating water are likely to have the greatest impact on the poor? What are the likely equity and efficiency considerations?

### ***Gender***

In what specific ways does commercialization of smallholder agriculture impact on gender relations? How do women farmers get access to resources and information? How do questions of access and control over resources impact on the participation and investment decisions of women farmers in profitable commercial activities?

### ***Technology***

What explains the differential use of alternative technologies? What technologies are cost-effective and under what conditions?

### ***Farm Profits***

What are the implications of inefficient use of pesticides on farm profits and consumer health?

### ***Health***

What are the health implications of diverting products, which do not meet export standards, to domestic markets?

### ***Markets***

The accepted wisdom is that unscrupulous middlemen exploit farmers. But is this a useful paradigm for designing market interventions? The case study suggested the following:

- Market intermediaries rarely knew or provided important information such as price trends, seasonal requirements, market product specifications or quality standards.

The cost of acquiring such information was high, precluding many smallholder farmers from using such information to make production and investment decisions.

- Rural assemblers faced high opportunity costs in collecting small volumes of product from large numbers of producers scattered all over the rural areas.
- Many producers continued to sell to particular market intermediaries even when they were dissatisfied with the service because they could not find an alternative market outlet or because the cost of finding and/or negotiating with an alternative buyer was too high.
- Market intermediaries could misinform farmers about overall market conditions, wrongly claiming that the quality of produce deteriorated in transit, or delaying payments because of imperfections in information collection and dissemination systems.
- Most farmers and market intermediaries relied on their own funds to finance production and trading activities. There was a lack of credit available for lending despite the need for production and trading credit. Formal credit was not available for traders because lenders either found it difficult, or encountered high costs, to assess the creditworthiness of potential borrowers. This high cost of acquiring information on potential borrowers is reflected in widespread failures of credit markets in rural areas.
- Farmers lost cash income because of the high cost of enforcing contracts.
- Both production and trading were characterized by high levels of uncertainty about the availability of markets, the quality of the product and the conditions of trading.

Given the complex production and trading environment in which smallholder farmers operate, is it likely that they will survive in the highly competitive and “exacting world” of horticultural exports where high transaction costs in the smallholder sector typically favor large producers? Our research suggests that marketing interventions in the horticultural sector must focus on improving the competitive advantage of smallholder farmers through improvements in the efficiency of markets and lowering of transaction costs that arise from high cost of information, contract enforcement and negotiation in marketing transactions. The focus of research and development efforts should be to increase the returns to farmers through the promotion of transparent marketing activities and combination of marketing functions that exploit economies of scale and improve information flows between market participants and farmers. Promising initiatives in this area include contracting options that reduce rather than impose additional costs on smallholder farmers, interlocking markets that combine input provision and produce marketing, effective group marketing schemes that reduce unit marketing cost and improvements in collection points to better serve farmers’ needs. A closer examination of the design of innovative marketing interventions that focus on the realities of cost of production, marketing and trade in rural areas can translate potential for income generation in real and sustainable income-earning opportunities for large numbers of smallholder farmers.

## Literature Cited

Ministry of Agriculture. 1996, 1997, 1998, 1999a. *Makueni district annual reports*.

Ministry of Agriculture. 1996, 1997, 1998, 1999b. *Meru Central district annual reports*.

Central Bureau of Statistics. 1994. *Welfare monitoring survey II*. Ministry of Planning and National Development.

Kimenye, L. N. 2000. *Case study of factors affecting horticultural production and marketing in Kibwezi division, Makueni district*. Kenya: Cooperative for Assistance and Relief Everywhere (CARE).





# Water Policy and Law in a Water-Scarce Country: Implications for Smallholder Irrigation in Kenya

*Chris Huggins*<sup>1</sup>

## **Introduction**

Today, Kenya is categorized as a *water-scarce* country, with an annual internal water availability of just 636 m<sup>3</sup> per capita.<sup>2</sup> Availability of surface water in Kenya is subject to great temporal and spatial variation. This variability is not adequately managed by the existing water-storage infrastructure, which is often poorly maintained. The increasing numbers of water users have led to a reduction in the dry-season flows of surface water and this reduction is exacerbated by climatic factors and degradation of watersheds. The exact nature of the groundwater resource is not fully documented, and the water table is falling in certain areas due to overabstraction from aquifers.

The scarce water resources are being utilized for an increasing number of domestic, industrial and agricultural uses, with irrigation being the major consumer of water. The Government of Kenya is committed to promoting and supporting the expansion of smallholder irrigation to provide improved incomes and livelihood security to farmers. For the smallholder irrigation sector to expand, the available water resources must be adequately protected from degradation, and allocated between a range of competing uses. Because of the limited funds available to the relevant state institutions, monitoring and regulation of these water uses are a difficult task.

The recently formulated Water Policy and the Draft Water Bill represent major changes to the national water-management regime, while the draft Irrigation Policy has major implications for the smallholder irrigation sector. Although it is beyond the scope of this paper to evaluate all the implications of these three documents, it refers to them to describe the water allocation system in Kenya and to provide an overview of the key issues affecting water availability at the national level for smallholder irrigation. These issues include:

- decentralization of water management responsibilities
- contrasting strategies of supply-oriented water development and demand management
- institutional coordination and institutional adaptation

---

<sup>1</sup>African Centre for Technology Studies.

<sup>2</sup>Compared to a value of 3,759 m<sup>3</sup> for neighboring Uganda.

The paper also examines whether the legal framework is reflected by actual practice. A case study of water issues affecting smallholder irrigation schemes in the Taveta division, Taita-Taveta district, provides an insight into the ways in which the laws and policies are enforced, and the ways in which they are perceived by the farmers.

The paper concludes by outlining the key challenges to be faced in the future, and options and opportunities for effective water management in a situation of national water scarcity.

## **Water Management Regimes in Kenya**

### ***Customary Water Management***

Water management did not originate with the legal systems established by the colonial government. In precolonial times, management of water was an integral part of the overall customary laws and behavioral norms of each tribal society. Some of these customs are still in practice while others have been discarded or modified.

Water regulations varied considerably between different cultures, particularly between those living in areas of high and low water availability. However, at the risk of generalizing, it is possible to say that ownership of water sources was usually vested in the political institutions of the local community rather than in the household. Sometimes, the community unit was the clan rather than the village, which is the case amongst the Borana pastoralists of northern Kenya. Water was rarely “owned” exclusively by a single clan or village. Access by others was often allowed, subject to permission being sought and, sometimes, reciprocal arrangements being made. This may have been facilitated by clan links, as in the case of the “agricultural Pokot” and the Marakwet of Kenya’s Rift valley, who have a system of mutual assistance (access to land or water) for households of the same clan.

Often, a distinction was made between different water uses. According to the customs of many tribes, any water source, even on private land, was traditionally free for *domestic* use by anyone. However, as regards water for cattle, permission had to be sought and it was possible to charge people for use of a private water hole (Ramazzotti 1995). Agreements over water use are particularly important amongst societies that are highly mobile, as reliable access to water is vital for pastoral migration routes. It is partly for this reason that pastoral societies have developed wide-ranging kinship networks that allow negotiated access to water and grazing rights among the territories of their clan, tribe and, sometimes, amongst other tribal groups. This is an example of political structures being shaped by the challenges and opportunities posed by the need to gain access to water.

Customary systems of water management were by no means static. Regulations and technologies altered over time, and innovations were introduced as a result of cultural exchange and experimentation. Water technologies have been altered and refined, and have spread geographically. In some places, irrigation was introduced by immigrants and was not readily adopted by the “original” inhabitants. The increasing trend of irrigation in dryland environments in Kenya is, to a large extent, the result of population pressure in areas of high

agricultural potential, as people migrate due to land fragmentation. However, it may also be the result of innovation amongst existing dryland communities (See Scoones 1992; and Kunzi et al. 1998). The Maasai of Rombo in the Kajiado district, Kenya, for example, did not readily adopt irrigation as a means of livelihood when Chagga, Gikuyu and others brought the technology to their area. Instead, the Maasai benefited from their role as landlords for many years, and it is only recently that some of them have started to cultivate or have taken an active role in water management.

To summarize, most indigenous systems of water management in Kenya are based on the concept that access to water was guaranteed for each individual by virtue of affiliation with a specific community (e.g., tribe or clan). Water use was regulated and controlled by the political leaders of each community (e.g., chiefs, elders, clan leaders). Water sources that were readily accessible (e.g., bodies of surface water) were generally regulated by the leaders of the community for the benefit and use of the community as a whole. The amount of control exercised over a water source by an individual or a household increases in proportion to the degree of labor invested in the water source.

This is the background on which modern governance structures were superimposed.

### ***Colonial Governance and Water Management***

During the colonial era, white settlers had a legally protected priority right to water sources, and large-scale water development was largely associated with urban administrative areas and white-owned farms and ranches. Many water points in the semiarid districts, particularly in the Maasai areas, were expropriated by the state for use by settlers. Large-scale irrigation schemes were constructed from the 1930s onwards, using the labor of political detainees during the 1950s.

Colonial administrative structures were based on the principle of “indirect rule,” which attempted to utilize adapted forms of “traditional” institutions to effect the colonial policy. Rural governance revolved around the chief who was responsible for a location. Few cultures in Kenya had a position of customary chief, and this was generally imposed upon local power structures. The chief was appointed and some of the local elders were more-or-less “coopted” onto the side of colonial rule, to advise him and support his decisions. The chief was given significant powers to enforce local bylaws and ensure that “voluntary” community activities took place. Generally, governance at local levels was based more upon enforcement than on incentives. However, every chief would have a unique relationship with the community, depending on local politics. Some could be very effective in mobilizing the community for water development or catchment protection. However, in the eyes of many local people, the identity of the chief has been, and remains, that of a *Kanu* (party-political man) rather than of a civil servant with a role in development.<sup>3</sup>

Since 1999, the power of the chief has been considerably reduced and more responsibility for developmental issues has been entrusted to District Committees. Some chiefs are respected and can be more effective than the District Committees in mobilizing the community for

---

<sup>3</sup>Interview with D.N. Mauro, Taita-Taveta District Development Officer, October 2000.

development purposes. These chiefs now find themselves frustrated at their reduced powers to enforce bylaws. Local administrative structures are further discussed below.

### ***Post-Independence Water Management***

From the 1950s until approximately the mid-1980s, the concept of community responsibility for water management was replaced by the perception that the state was the legitimate provider and manager of water services. The government implemented thousands of water supply schemes, constructed irrigation infrastructure and largely carried the responsibility of O&M of these schemes. Those communities that were supplied with water from government schemes ceased to see themselves as the principal guardians of their water resources.

Since approximately the mid-1980s, there has been a realization that the government does not have the financial capacity to be the sole provider of water services in Kenya. In particular, the high costs of O&M of water supply and irrigation schemes are beyond the means of the state. The government has been attempting to hand over responsibility for the management of water infrastructure to communities themselves. In addition, the dated “top-down” approach to development has been shown to lead to unsustainable projects, due to a lack of feeling of “ownership” of water points by local beneficiaries, and to projects that are inappropriate for local needs. Especially in the smallholder irrigation sector, donors and the relevant agencies are now insisting that communities mobilize themselves to seek assistance. Communities are required to fulfill a number of tasks before implementation of projects, in order to demonstrate group cohesiveness and management capacity

Therefore, there has been a reevaluation of the role of community institutions, which include customary management regimes as well as the more modern “committee” structures.

The survival of these customary systems and their relevance today vary widely across the country. The extent to which they survive and retain their ability to encourage sustainable use of water resources is a matter of contention. Many scholars argue that the ability to regulate use has been eroded by changes in community institutions, the expansion of populations, and the use of new technology that can involve abstraction or pollution of great volumes of water. Migration can also result in the undermining of sustainable use regimes. Amongst some groups inhabiting high-potential areas, control of water was vested, to a greater extent, in the individual household. Amongst the Gikuyu of Kenya for example, water availability on inherited land is traditionally seen as “God-given.” Thus, a household with riparian access to water could often abstract large amounts for private use even at the risk of resource depletion or at the expense of the community in general. Such households would be tolerated by society unless “the actual survival of members of the community is seriously threatened” (Kunzi et al. 1998). While this system has worked well in the well-watered homelands of the Gikuyu, it may not be sustainable in the drier areas where many Gikuyu now live (ibid.).

It is clear that customary water management regimes *may* often represent useful mechanisms for sustainable water management, due to the credibility of customary institutions in certain rural communities. However, this is not necessarily the case. Researchers in the field of water law should investigate a key research question: to what extent can national water legislation and policy support existing sustainable practices, while regulating unsustainable outcomes of customary practices? The decentralization of water resources management to the “lowest appropriate level,” as advocated in the Dublin Principles, is one component of an

“enabling environment” for customary practices. Water User Associations (WUAs) can include customary groups such as clan-based organizations, as are found for example in irrigation systems in the Elgeyo-Marakwet district. “Modern” committee structures can be supported by the authority of customary institutions. Customary water-management regimes can adapt themselves to changes in new technology and changing institutional contexts such as increased cooperation with donors and ministries. However, customary norms may contradict donor and government requirements, such as those encouraging gender equity. It is for this reason that a truly community-based approach must be followed to create an atmosphere of negotiation and mutual understanding between interest groups.

### ***The Roots of the Current Water Law***

The legal regime for water management in Kenya has evolved from English “common” law. In line with the Roman roots of the English legal system, water was classified as a public good. Therefore, there was no legal possession of water in an absolute sense, only rights of use. Rights of use, according to English law, were dependent upon physical access to water, which essentially meant ownership of riparian (riverbank) land or ownership of land, which allows access to groundwater beneath it. It was also dependent, in the case of surface water, upon the rights of other riparian users who had a share of the water upstream or downstream. Their rights to reasonable use could not be prejudiced by upstream abstractions. However, those who did not have riparian rights had no other rights over the resource. This meant that citizens, in their capacity as members of the public, had no legal right to complain over misuse or overexploitation of water resources.

User rights were also dependent on the water use being of a “reasonable” nature, the characteristics of reasonable use being decided in the courts as necessary. However, in the case of groundwater, use was unrestricted, meaning that aquifers could be tapped to an unlimited degree by landowners. There was also no obligation to ensure that an amount was abstracted that did not reduce the aquifer underneath the land of a fellow citizen. It can, therefore, be seen that although water was characterized as a “public good,” considerable private rights were conferred upon individuals, essentially based on landownership criteria. These contrasting poles of “public” and “private” rights are useful yardsticks for the analysis of water policy and law.

This legal framework evolved in a water-abundant country, and did not place stringent controls on water use or encourage the use of water for “the greater good,” or for the most economically efficient use. It is clearly not appropriate in a water-scarce country such as Kenya.

### ***Modern Water Legislation***

The Kenyan Water Law has been considerably altered from this original English model. However, the concept of water as a public good remains, with the state taking the role of the trustee of the public interest in water management. Essentially, all water in Kenya belongs to the state, with specific rights being parceled out under certain conditions. The permit system

has been used to regulate the allocation of private rights to water.<sup>4</sup> There are some uses of water that do not require a permit. These include abstraction of water for domestic use that does not involve “the employment of works” (MENR 2000), such as canals or pumps, and the use of a hand-dug well that is situated a minimum of 100 yards from a body of surface water. It is an offence to abstract water *by any other means* without the appropriate permit.

The role of holder of the public trust demands very high levels of accountability, and the state must be perceived by the public as valuing the public good above other, more political, concerns. The Ministry-in-charge of water affairs has had mixed results in this regard.<sup>5</sup> Projects such as the Turkwel dam have been the subject of contention, with doubts being raised over their utility for the greater good. At the local level, plenty of instances can be found of socially or politically “connected” individuals and institutions being able to avoid the legal requirements of the Water Act. The increased importance of the regulatory and coordination roles of the Ministry currently in charge of water affairs, the Ministry of Environment and Natural Resources (MENR), requires that it is able to avoid political interference. In order to be accountable, it should also separate its functions of project implementation from those of regulation, water allocation and monitoring.

In the past, the Ministry in charge of water management generally focused on water development, especially for domestic use. This has been prompted by the fact that access to water, even for domestic use, is still limited in Kenya. In 1972, only 9 percent of the total rural population were supplied by “safe” water schemes. This had risen to approximately 20 percent by 1989, and the current ratio is around 42 percent. (Thuo 2000). There is obviously a need to improve the water supply infrastructure. However, MENR is now attempting to move away from an emphasis on domestic supply towards a view of water as a catalyst for socioeconomic development and poverty alleviation. It is also attempting to move away from a purely supply-oriented approach to incorporate demand-management strategies. Demand management is practiced due to the recognition of the fact that water is a finite resource, and that any use of water has opportunity costs, possibly including lost environmental benefits. As water is an economic as well as a social good, it makes sense to use financial and other instruments to ensure that it is available for the uses which best balance “basic needs” (e.g., for domestic use), economic efficiency and environmental benefits.

Demand-management approaches can involve a) innovative ways of accessing water (including rainwater harvesting, for instance), b) public education campaigns to encourage water conservation and reuse, c) subsidy of more efficient water technology, d) financial incentives for voluntary water rationing, and e) transfer of water rights to the most efficient end use. There is also a need for the Ministry to move away from a technical bias, reflected in the dominant position of the Department of Water Development, and develop improved expertise in legal, policy and socioeconomic fields. Improved capacity in these areas will enable the Ministry to take on its new role as an arbitrator of water-use conflicts and as a regulator of water allocation and abstraction.

---

<sup>4</sup>This is similar to the water regulation regimes of the vast majority of countries across the world.

<sup>5</sup>The term “Ministry-in-charge of water affairs” is used because the title of the relevant Ministry has been altered many times.

## Policy Formulation in the Water and Irrigation Sectors

### *National Policy on Water Resources Management and Development*

Approximately twenty-five pieces of legislation, in addition to the National Irrigation Board Act and the Water Act, have implications for water management (including, e.g., laws relating to forestry, agriculture and industry). Despite this, prior to 1999, no comprehensive policy statement existed for the water sector. This complex situation led to many ambiguities, “gray areas,” institutional conflicts and a lack of overall focus on the water sector.

Major donor-funded attempts to formulate an official water policy date from at least 1993/1994, when the Swedish International Development Agency (SIDA) funded a number of policy-formulation workshops. A draft document was eventually produced, but it was never publicly released. In the absence of a water-policy document, the Ministry’s water management strategies could be formulated on a fairly ad hoc basis, rather than according to clear long-term objectives. Without a clear policy statement on the prioritization of water projects according to specific criteria, it is more likely that political considerations and donor preferences will influence the selection and funding of projects.

The first Kenyan water policy was approved by the parliament in April 1999. Sessional Paper Number 1 of 1999 on National Policy on Water Resources Management and Development (hereafter termed “the water policy”) has been well received by most stakeholders in the water sector. However, as acknowledged by the Minister for Water Development, “it was apparent during the parliamentary debate... that the document was not adequately publicized to create the necessary ownership and understanding amongst the stakeholders to enhance its acceptability.”<sup>6</sup> This lack of ownership amongst the stakeholders is evidence of a formulation process that has not involved all the relevant stakeholders. This fact is in contrast to the calls in the policy for integrated approaches to water resources management, which should include the input of the private sector as well as all relevant government bodies.

The policy begins with a discussion of challenges in the water sector in Kenya. It acknowledges the uneven temporal and spatial distribution of water, and the negative impacts of human activities in water catchment areas that have affected the availability and quality of water. It also notes the lack of adequate interlinkages between the Ministry-in-charge of water (which, in the past, has been primarily concerned with domestic supply) and other water-related sectors. Other problems identified in the policy include “an overcentralized decision-making process, inappropriate and rundown monitoring network, inadequate database, discontinuous assessment programs, uncoordinated source development, nonoperative water rights, absence of special courts to arbitrate on water use conflicts and a generally weak institutional setup.” Some of these points will be elaborated on in this paper.

---

<sup>6</sup>Speech delivered by the Minister for Water Development, Hon. Kipng’eno Arap Ng’eny, at the Workshop on Water Legislation and Policy, as Relates to Poverty Alleviation, Kenya College of Communications Technology, 2–4 February 2000.



The policy acknowledges the inadequacies in the Water Act, noting particularly that the act has no provision for the management of conflicts between different stakeholders. Key areas of conflict relate to different end uses of water, different institutions dealing with water issues and different districts within Kenya, and to relations between Kenya and neighboring countries.

The policy emphasizes the importance of the river-basin approach to water resources management, and the need for groundwater conservation zones to avoid depletion of aquifers. Other recommended actions include:

- The establishment of Community-Based Water Committees, with clearly defined roles, at the district level.
- The establishment of hydrologic, hydro-geologic, water quality, water permit and socioeconomic databases at all levels of the water-resources management.
- Mandatory Environmental Impact Assessment for all major water development activities.
- Storage of surface water, supported by the government, for irrigation.
- The definition of roles, and the establishment of performance-monitoring systems, for all actors in the water sector (role definition and monitoring criteria to be established by the Ministry-in-charge of water)
- The establishment of a tariff structure for water abstraction, commensurate with the amount of water abstracted, in order to fund water-management activities.
- The establishment of a National Standing Committee to deal with crosscutting water-related issues.
- The development of a National Policy on Land, Water and Forests.
- The establishment of a National Water Conservation Program, which will fund construction of water storage facilities and protect water catchments.

Many of the key principles of the policy reflect the influence of the Dublin Principles and policy guidelines of the World Bank for water resources management. (World Bank 1993). These, as well as other recommendations, are included in an Action Plan, complete with a time frame. Perhaps most significantly, the Action Plan advocates a phased approach to the decentralization of decision-making processes in water-resources management. As a first step, government institutions for water management will be established or strengthened in the following hierarchical order: the national level, the basin level, and the subbasin/catchment level. Following this process, *decision-making processes* will be decentralized to the basin level, and then to the subbasin/catchment level. Finally, all vital water catchments will be gazetted.

The policy has resulted in the formulation of a draft Water Bill. An early version of the new Bill was presented at a workshop involving a fairly wide range of stakeholders, in early 2000.<sup>7</sup> At that time, the feeling of many stakeholders was that the new Bill was not representative of the Policy, as the proposed changes to the existing Act were not sufficiently thorough (personal observation). Sources in the Ministry report that a final workshop was convened in mid-2000, which resulted in the current draft, which is considerably different from the first version. The Bill has now been submitted to the Cabinet and is soon to be tabled.<sup>8</sup>

### *Policy in the Irrigation Sector*

At the time of writing, no official policy exists to guide the irrigation sector. The Irrigation Act is the principal legal document in the sector. It was formulated in 1966, specifically to provide guidelines for tenant-based national-irrigation schemes, under the National Irrigation Board (NIB). It is of little relevance to the smallholder irrigation sector, and it is unlikely that additional tenant-based schemes will be undertaken (see paper by Kabutha and Mutero).

Two government bodies have principal responsibility for the development and management of irrigation in Kenya. The NIB was established in 1966, by the Irrigation Act, as a statutory body under the Ministry of Agriculture (MoA). The NIB has responsibility for national irrigation schemes in Kenya, such as Mwea and Perkerra. It has not been active in the smallholder irrigation sector.

The Irrigation and Drainage Branch (IDB) of the MoA was developed from the Small-Scale Irrigation Unit, established in 1977. The main duties of the IDB are “to establish an institutional framework for the planning and implementation of smallholder irrigation,” and to “formulate appropriate irrigation policy for the whole country” (MoA/KARI 1987).

The draft irrigation policy was prepared by the IDB in October 1998, and is largely a product of a national workshop held in 1992.<sup>9</sup> It is a response to the inadequacies of the Irrigation Act, and the lack of any comprehensive national planning for the irrigation sector in Kenya. The draft policy mentions the lack of a national irrigation and drainage policy and master plan as a constraint to development that has resulted in “duplication of effort, wastage of scarce irrigation resources and haphazard interventions” (MoA 1998).

The draft policy acknowledges that the Irrigation Act “be amended to give clear provisions for the management and coordination of irrigation activities and provide for community participation in planning and implementation of irrigation projects in Kenya” (ibid.).

The draft policy notes the high capital costs of constructing irrigation schemes and thus states that “the government will encourage the development of low-cost gravity systems and use of local manpower and other resources for cost reduction.” This emphasis on gravity schemes has implications for the water-delivery technologies that may then be employed and, therefore, on the water-use efficiencies of the schemes; for example, high-pressure

---

<sup>7</sup>Workshop on Water Legislation and Policy, as Relates to Poverty Alleviation, Kenya College of Communications Technology, 2–4 February 2000.

<sup>8</sup>At the time of writing (April 2001).

<sup>9</sup>By far the majority of the participants at the workshop were from the relevant Ministries, while other stakeholders included university staff and representatives of NGOs. See Kimani and Otieno 1992.

sprinklers (which are more efficient than furrow water-distribution methods) cannot be operated using gravity systems. While the draft policy notes that water scarcity is a problem that the irrigation subsector has to face, it arguably does not sufficiently address these issues. However, it does say that “appropriate and efficient technologies,” as well as storage and regulation facilities, will be promoted by the government.

The document also recommends the formulation of a National Irrigation Master Plan. The document gives priority in future irrigation and drainage activities to “commercially oriented smallholder group-based irrigation schemes,” rather than to extensive government investment in “food security” schemes producing subsistence crops in dryland areas. It may be felt that NGOs will support these schemes, while the government will concentrate on investment in areas where it can share costs of irrigation development with the farmers. However, there is perhaps some internal inconsistency in the policy, which states that priority will be given to “areas that are already settled and have basic social infrastructure,” but it also recommends the promotion of large commercial estates in sparsely populated ASAL areas. Presumably, it is envisaged that the commercial nature of such schemes will require only minimum government investment. However, the water demand of these large schemes will have to be carefully evaluated and seasonal aspects, in particular, will be significant.

### *Decentralization of Responsibilities in Water Management*

As has been mentioned above, the water sector in Kenya has been dominated in the past by the Ministry-in-charge-of water affairs, with the vital role of other stakeholders only recently being adequately acknowledged. The Ministry itself has been a highly centralized institution. However, the Draft Water Bill aims to assist in a process of decentralization within the Ministry, in order for it to become more responsive to local demands. The approach to decentralization of some of these responsibilities is outlined below.

Currently, the principal body for the apportionment of water rights is the Water Apportionment Board (WAB). To fulfill this role, it requires data on water use from the IDB, the River Basin Development Authorities (RBDAs), and other institutions. The exchange of these data has been very limited. In particular, the reticence of the River Basin Authorities has been commented upon in official studies (MoWD/JICA 1992).

In addition to the WAB, there are currently 6 Catchment Boards and about 65 District Water Boards. The Catchment Boards lack resources to operate very effectively. They also, in many cases, lack the political support as well as legal power to have their decisions implemented. The District Boards currently follow the administrative district boundaries, and this has led to a conflict between them and the Catchment Boards, which naturally have a weaker affiliation with district or provincial apparatuses.

The six RBDAs in Kenya were formed with the prime objective of planning and coordinating development activities.<sup>10</sup> However, the mandate given to them has resulted in unclear delineation of responsibilities between them and other government institutions. Their

---

<sup>10</sup>The six are: Kerio Valley Development Authority, Lake Basin Development Authority, Coast Development Authority, Tana and Athi River Development Authority, Ewaso Nyiro North Development Authority and Ewaso Nyiro South Development Authority.

“advisory role” is unsupported by mechanisms to encourage or ensure cooperation from other institutions, particularly the District Development Committees (DDCs), which generally see the RBDAs as threats to their authority. There is also an “overt conflict” between the RBDAs and the Water Bailiff.<sup>11</sup> The RBDAs do not have powers to allocate water; however, their planning role implies that they should regulate the apportionment of water in their area. This puts them into direct conflict with the Catchment Boards. The institutional framework proposed in the Draft Water Bill, as outlined above, would give the RBDAs representation on the River Basin Authorities, effectively subsuming them into MENR structures for water allocation and water-development planning.

According to the terms of the Draft Water Bill, the WAB would be abolished. In its place, a National Water Board would be established. This would be the central body for the allocation of water rights, the coordination of River Basin Boards and District Water Boards (see below), the management of data banks, monitoring of water resources, and all other key functions of the MENR. Of the total membership of 11 of the National Water Board 5 persons are “chosen by the Minister from among the private-sector, user and environmental interests” (MENR 2000). The multi-stakeholder nature of the National Water Board may be favorably contrasted with the existing WAB, which is composed solely of Ministry employees and other government officials.

In practice, many of the functions of the National Water Board will be delegated to River Basin Boards. They will approve the applications for water permits from within their catchments, and will also formulate recommendations on water use and conservation, and monitor and enforce water use in the catchment area. The formulation of the river basin conservation plans should, according to the participatory principles of the Draft Water Bill, be essentially a bottom-up process. Policy formulation should, therefore, be informed by the District Development Committees and District Environmental Committees, as well as the opinions of local stakeholder groups. Arguably, the principles of stakeholder participation in such processes, and the dissemination of decisions made by institutions such as the River Basin Boards (in a form that is easily understood by the “average” water user) should be outlined in the Water Policy and/or the Draft Water Bill. Dissemination should take place *before* the plans are finalized, and could involve locally appropriate measures such as poster campaigns.

According to the Draft Water Bill, the current system of District Water Boards, which mirrors administrative boundaries, will be replaced by a new set of District Water Boards, which would follow hydrological catchment boundaries, termed “subbasins” within the river-basin areas. Two or more *administrative* districts would often be represented by just one District Water Board. The representation of administrative districts by the Boards would probably become a highly charged political issue, and the delineation of the boundaries of the District Water Boards may also be contested. This is because the communities within them represent political constituencies. In Kenya, the ability of an MP or a member of the administration to attract development projects to an area is seen as one of the keys to political success. The MENR will have to ensure that it is able to isolate itself from political interference. However,

---

<sup>11</sup>Mr. Nyarao, Water Rights Specialist, MENR, speaking during the National Workshop on Water Legislation and Policy as Relates to Poverty Alleviation.

it must arguably also avoid using purely hydrological factors to set District Water Board Boundaries, as the geographical and political realities of the communities on the borders between them will be significant in development and conservation activities.

The membership of the District Water Boards would include a representative of WUAs from the subbasin. In many cases, the most powerful WUAs represent the interests of major landowners and large-scale commercial irrigators, rather than the local communities. While the most organized WUAs are most able to debate with government representatives, it is also important that the interests of the “typical” water users in the area are represented. It might be prudent for the Bill to specify that at least one WUA from each of the main water sectors should be represented, including the smallholder irrigation sector.

### *Local Administrative Structures*

Following the District Focus for Rural Development strategy, implemented in 1983, a hierarchical structure of District, Divisional, Locational and Sub-Locational Development Committees forms the basis for decentralized development planning and implementation.

Development plans, including those for smallholder irrigation, are eligible for government support and funding only if they are forwarded up the institutional hierarchy, and are discussed at each stage. However, projects can be implemented in the district without having been proposed by the DDC. One study found that of 82 projects implemented in the Kajiado district during a specific period, only 38 had been proposed by the DDC (Southgate and Hulme 1996). The District Commissioner (DC), who chairs the DDC, is also the Chair of the District Executive Committee (DEC). A number of studies have concluded that the DFRD policy, despite its avowed aim of decentralization, has in fact led to increased control of central government at the local level. The DC, a political appointee, is responsible to the Office of the President, rather than to a local electorate. The DEC, comprising the DC, District Development Officer, and departmental heads of all Ministries in the district, is the real source of authority in terms of allocation of funding for development projects. Some analysts have commented that “decisions are not primarily taken with respect to projects but with respect to the machinery of sectoral ministries” (Sottas et al. 1998). In addition, political interests have a heavy influence in the selection process.

The divisional, locational and sub-locational meetings, in many instances, are not convened regularly (Sanyu Consultants Ltd. 1999; Southgate and Hulme 1996). If this is the case, local interests might best be served by a more flexible framework that gives institutional authority to a variety of local organizations. Associations, subcommittees and their equivalents should be able to federate themselves at any level to pool resources and coordinate activities. “Mobilization of the community needs to be based on a wide definition, the ultimate objective being to make the community self-reliant. A plurality of different organizational forms should be allowed with no predetermined organizational structure being “imposed” on the community” (Anonymous 1999).

## Challenges for Sustainable Management of Kenya's Water Resources

The sustainable use of water resources demands that the quantity and quality characteristics of the resources are well understood by those allocating water rights. There is also a need for protection of water-catchment areas, and the effective allocation and enforcement of water-abstraction permits.

Planning for sustainable water-resources development demands an accurate database of hydrological information, including data on baseline river flows in different seasons, abstraction rates, groundwater levels and water quality. Currently, the database in Kenya is patchy and poorly consolidated, being scattered among different institutions and reports. Of the 928 hydrological monitoring stations existing in 1990, only 505 were operating. Since that time, many more have been damaged by the El Niño floods and there is little money available to repair them or to pay staff to collect the data.

In terms of groundwater, most of the surveys conducted have consisted of basic reconnaissance work: "quantitative aspects of groundwater flows were rarely taken into account, recharge zones were not delimited, and the effect of pumping on artesian aquifers was not specified" (UN 1989). The Registrar of Water Rights has commented that knowledge of groundwater potential is still limited.

Although government policy is to avoid interbasin water transfers whenever possible, for reasons of environmental sustainability, the government is considering transferring water supplies from high-rainfall areas to the drier areas.<sup>12</sup> This process would require a more comprehensive database on water resources than is currently available.

Official documents recognize that the preparation of a complete inventory of present river conditions "will take many years" (MoWD/JICA 1992). The lack of such an inventory has contributed to the current problems of overabstraction, as indicated elsewhere in this report. Currently, calculations of base-flow and flood-flow rates are based on measurements made by the District Water Bailiff at the point of abstraction. Frequently, irrigators time their applications so that these measurements are made during a time of high flow; because the farmers pay for the fuel used by the Bailiff, they can influence the timing of the operation (Sottas et al. 1998). There is a need for long-term data on streamflow (measured over a series of years) to be made available to Water Bailiffs across the country. This would demand investment in information-management systems as well as monitoring capacity in the national water quantity.

There is also a fundamental misunderstanding amongst some stakeholders regarding the 30 percent minimum flow level of surface waters, which is to be reserved for domestic uses and maintenance of ecological systems. Some abstractors have assumed that they must leave a minimum of 30 percent of whatever flow remains in the river at the point at which they do the extracting. However, the 30 percent ratio refers to the aggregate base flow of the river, and is meant to ensure that 30 percent of the "natural base flow" continues to flow into the sea, or the usual termination point of the river. The calculation of this 30 percent ratio then depends upon a comprehensive understanding of the characteristics of the river along its entire length, under different seasonal conditions.

---

<sup>12</sup>This was noted, for example, by participants during the National Workshop on Water Legislation and Policy as Relates to Poverty Alleviation. Several interbasin transfer schemes are listed in the MoWD/JICA 1992.

Therefore, two interlinked factors, the lack of data on river flow and poor coordination of water-apportionment bodies, have hindered the sustainability of surface-water abstractions. Cases exist of a number of permits being issued for a single source of surface water so that the quantities of water corresponding to these permits add up to more than the average flow of the river. It has even been noted that “in some basins in high-potential areas... the abstraction volume permitted by WAB appears to have already exceeded the available natural flow” (MoWD/JICA 1992).

The Draft Water Bill includes a number of conditions to be attached to permits for irrigation. For example, permits for irrigation demand that the irrigated land will be efficiently drained, and that used or unused water flowing from the land will be delivered “to a watercourse or a body of water or drainage or other works” (MENR 2000, 35).

A number of conditions *may* be attached to a permit. These include data on water quality, the quantity of water to be abstracted, the quantity of water to be returned to a specific water body or drainage area, area of land on which the water may be used, and the WUA involved as well as others. However, it remains to be seen whether or not the MENR staff will stipulate that these conditions are met, or will analyze the information received. The greater the amount of information demanded the more the time and money that have to be invested in processing that information.

For sustainable water management in a country with extreme seasonal variation in water availability, perhaps the most significant factor is the water-storage requirement for irrigators. The granting of an irrigation permit is intended to be contingent upon the provision of a 90-day storage facility. This is in order that irrigation water can be taken from the *flood-flow* rather than from the *base-flow* of a river. However, in practice, this requirement is very seldom met. The costs of such a facility, as well as the large parcel of land it would require are prohibitive for the average household, and the MENR does not enforce the rule. It is very difficult to propose a solution to this problem, other than a compromise based on storage facilities to be shared by a number of users. This shared system would however be prone to conflicts between users over access to the stored water.

The Minister-in-charge of water affairs has been given the power to gazette catchment areas that are threatened by environmental degradation. However, at present, very few have, in fact, been gazetted. There is no inventory of gazetted catchments.<sup>13</sup> The new Draft Water Bill gives the Minister-in-charge of water affairs sweeping powers to control activities, which have adverse impacts on water resources. These include the power to declare any activity to be a controlled activity, as long as the Minister is satisfied “that the activity in question is likely to have an adverse impact on a water resource” (MENR 2000, 16). It would be an offence to undertake a controlled activity without the authorization of the National Water Board. This section of the Bill gives the Minister so much power that it might be questioned on the basis of personal liberties as enshrined elsewhere in the Kenyan Law.

It has been recommended that the viability of proposed irrigation schemes be assessed, in addition to the usual criteria, on the condition of the watersheds that regulate the relevant water source. If the relevant watersheds are being poorly managed, the water supply scheme

---

<sup>13</sup>Various Ministry officials, commenting during group discussions, Workshop on Water Legislation and Policy, as Relates to Poverty Alleviation, Kenya College of Communications Technology, 2–4 February 2000.

might be compromised as a result. In this case, the community or the appropriate institutions in the district (the District Environment Committee, for example) should put in place measures to protect the watershed. This issue has not been tackled in the Draft Irrigation Policy, probably because the IDB and the NIB see watershed protection as extraneous to their mandate. It would be possible, however, for the policy to stipulate the need for NGOs as well as the IDB or the NIB, to liaise with the MENR and other relevant institutions over the management of the relevant watersheds before any proposed irrigation scheme is judged to be viable.

### *Case Study: Taveta Division*

The Taita Taveta district is part of the Coast province in southeastern Kenya. The district borders the Kajiado and Makueni districts to the north and west, and the Kwale district to the south. The Tanzanian border runs along the southwestern border of the district. Of a total area of 1,695,900 hectares, only about 249,400 hectares are arable. Private ranches, large commercial agricultural estates, and national parks occupy a significant percentage of the district area. In 1994, the population was estimated at 300,000. Most of the district is semiarid, categorized as agro-ecological zones V or VI, and is thus unsuitable for rain-fed agriculture.

The area has a range of water sources, including the Chala and Jipe lakes, and the Mzima springs that rise in the Tsavo West National Park, and are piped to the Mombasa municipality. Four major rivers run through the district: the Voi river, the Mbololo river and the Bura river (with their sources in the Taita hills), and the Lumi river which originates in the Kilimanjaro slopes. However, the distribution of surface water varies greatly across the district. Surface water sources arising from springs are not generally prone to extreme seasonal variation. Most of the surface water flows are fed by melting snow on Mt. Kilimanjaro so that water flow variation involves *increased* flows during the dry season and low flows during the wet season.<sup>14</sup> Groundwater is generally found close to the surface, and pumping from shallow wells does not require very powerful pumps (IDB 1994).

Irrigation in the district has a long history, especially in places such as Wundanyi, in the Taita hills, but indigenous systems are not very significant today. "Organized irrigated agriculture" dates back to colonial times when the schemes were implemented in the early 1940s (ibid.). The great majority of irrigation activities (approximately 90%) of the district are found in the Taveta division, one of the five divisions in the district. The district supplies a very large percentage of the fresh produce found in Mombasa's markets. However, the industry is hampered by the very poor state of the network of roads.

The irrigation potential in the district was estimated at 3,712 hectares in 1994, although this value has not been adjusted according to issues of fluctuating/declining water availability. Of this, 3,141 hectares are located in the Taveta division. The division can be usefully divided into two sections, the southern and the northern. The southern section has a high water table and some of this area is swampy. This area is fed by many small springs, and poor drainage is a limitation to agricultural production. However, the northern section is drier.

---

<sup>14</sup>Interview with Eng. Kinyanjui, DIE, October 2000.



Of the 30 potential projects in the district that have been proposed for development, 3 new group irrigation projects, covering a total of 120 hectares, have been implemented since the District Profile was prepared in 1994. According to the District Irrigation Engineer (DIE), there was an overall decline in the total irrigated area from 2,526 hectares recorded in the District Profile, to the current 1,511 hectares.<sup>15</sup> However, this value does not take into account the physical expansion of several schemes. Since the District Profile was compiled, the resources available to the District Irrigation Unit (DIU) have not permitted systematic and comprehensive assessment of the current acreage. In addition, this value may also exclude a significant number of individual farmers who are irrigating private plots using pumped water from shallow wells.<sup>16</sup> Staff bases at the DIU in the Taveta town estimate the total current irrigation acreage at 3,500 hectares. The discrepancy between this value and that provided by the DIE in Wundanyi demonstrates the limited institutional capacity to gather and collate information on irrigation activities. Of course, increased acreage implies that more water is being abstracted currently than in the past.

As noted above, there are a significant number of individual farmers who are irrigating private plots using pumped water from shallow wells. Many of these individuals use piped systems, but are reportedly switching to open furrow systems rather than replacing worn-out parts of the piped systems.<sup>17</sup> The vast majority of group schemes utilize gravity-fed canal systems, most of which are unlined, and therefore lead to water wastage.<sup>18</sup>

The last Water Availability Assessment Study for Taita Taveta was undertaken in 1993. At that time, there were 31 schemes, which were either proposed or actually present on the ground. The assessment concluded that of these 31 schemes only 5 could experience no water shortage, 16 would experience water shortages, even in a year experiencing average amounts of rainfall and 10 would experience shortage once in every 20 years.

In terms of the 16 schemes that were operating when the District Irrigation Profile was being prepared, the DIU estimated that only 2 schemes could definitely expect to operate without suffering from water shortages while 6 schemes would suffer serious water shortages, on average, every 5 years. More research would be needed to assess the water-security situation for the other 8 schemes.

It is clear that water availability in parts of the division is a key limitation to expansion of irrigation. Indeed, existing schemes may need to be monitored to assess their effects on scheme flows. However, due to the *apparent* abundance of water sources, especially in certain areas, the local administration has commented that “the district is well endowed with plenty of water, which flows to the Indian Ocean untapped.”<sup>19</sup> While there is an abundance of water in some areas, there are also episodes of localized water scarcity, and irrigation development in the district requires careful planning, based on hydrological data.

---

<sup>15</sup>Mr. K.B. Chiyonzo, Taita-Taveta District Irrigation Officer in IDB 1994.

<sup>16</sup>Interview with Mr. Chengo, District Irrigation Officer, October 2000.

<sup>17</sup>The extent to which water is “wasted” depends on the hydrology of the area, as well as subjective interpretations of the “value” of water for different uses.

<sup>18</sup>Mr. Calistous Akello, Taita-Taveta DC, paraphrased in the National Steering Committee, World Day to Combat Desertification 2000. These comments were echoed by other local officials during field-work.

<sup>19</sup>Interview with Eng. Kinyanjui, DIE, October 2000.

## *Water Management Issues at the Divisional Level*

All of the irrigation schemes in the division have water permits, and the usual period of time taken to process them is 3–6 months. It is clear that many of the farmers have expanded their plots beyond the area stipulated in the permits. This means that abstraction rates have almost certainly also exceeded the stipulated limits. However, it is impossible to accurately estimate water use, as none of the water-monitoring stations in the division are currently operational.<sup>20</sup>

Some of the schemes are affected by land disputes, as official demarcation of plots has not been conducted. This leads to minimal investment in the canal infrastructure and, sometimes, to increased water wastage as a result.<sup>21</sup>

Drainage of swampland is also a management issue in the division, as it has not been very well coordinated. In some cases, the water that is drained from one plot simply accumulates in the neighboring farm. Extension work in this area, combined with meetings involving all the affected farmers, could reduce this problem. One large drainage canal has been under the responsibility of the MENR, which lacks funds to maintain it. Farmers have yet to develop the organizational capacity to maintain it collectively.

The DDC meetings are held far from the Taveta division. There are no transport facilities, so the relevant stakeholders must fund transport from their respective budgets. The DIU, located far from the District Headquarters, is therefore not able to attend the DDC meetings, and prioritization of irrigation schemes (for recommendation to donors, for example) takes place in their absence. This may work against the best interests of the district.

The District Water Board is apparently not functional, although the District Water Officer is very active. The Assistant Water Officer, located in the Taveta division, undertakes visual checks of the actual or proposed water-abstraction regimes of water users seeking permits. He is not able to do rigorous quantification of data, largely because of lack of equipment. He then forwards the application to the District Water Bailiff. It is interesting to note that, in the last 3 years, the DIU had no direct contact with the District Water Bailiff.

In the past, the DIU had links with the Coast Development Authority, which is the relevant River Basin Development Authority for the area. However, there has been no communication from this authority for the past 3 years, and it appears to be “dormant” in terms of water-management activities.<sup>22</sup>

The best-known water issue in the district relates to the Njoro Kubwa canal, which dates from 1947. The canal runs through a large sisal estate owned by a local politician, before reaching a number of smallholder irrigation schemes. An agreement between the estate and the colonial government, dating from 1948, granted rights to 70 percent of the canal flow to the estate, while the local community was granted rights to 30 percent of the flow. Details of how the 30 percent was to be shared were not specified in the agreement. Frequently, the

---

<sup>20</sup>Interview with Eng. Kinyanjui, DIE, October 2000.

<sup>21</sup>Interview with Eng. Kinyanjui, DIE, October 2000.

<sup>22</sup>Interview with local government official, October 2000.

estate has been using all of the canal flow during daylight hours, and releasing the water at night. This was of great inconvenience to the irrigating communities, especially to the women farmers who may not be able to safely irrigate at night.

The situation has become worse after the maintenance of the canal deteriorated. Because of the poor condition of the section of the canal within the sisal estate, the water that was released for downstream use is unable to flow and simply drains into the estate's land. One of the irrigation schemes, Kitobo, has not received water for about 5 years, while another, Kamleza, has lacked water for the past 2 years. The issue of water flow, which concerns the legal rights of each stakeholder to the water, is bound with the maintenance of the canal. Because the water flow to the smallholder irrigation schemes was limited by the activities of the estate, the motivation for the scheme communities to maintain "their" portions of the canal also diminished. Community efforts are notoriously difficult to organize, and this difficulty is enhanced when the rewards of community labor are uncertain.

Responsibility for maintenance of sections of the canal outside of private lands also lies with the MENR, which currently lacks funds thus exacerbating the problem. However, it is planned that funding by the World Bank will be used for this purpose.

It is ironic that, as more responsibility is being transferred from government institutions to community organizations, the division actually receives less support from the District Development Officer than in the past, because of budgetary constraints.

The issue has been frequently debated at the DDCs at the district divisional and locational levels. A number of public meetings have also been held, particularly following threats of violence over the dispute. The MP who owns the estate has participated in some of these meetings (particularly around election time) and has, on occasion, promised to maintain the canal, but these agreements have not been honored. Some of the local people formed a "Divisional Water Board" to represent their interests in their attempts to gain access to the water for irrigation. This Board was composed of local elders, but was not able to exert very much influence, and the membership was not permanent. It was disbanded some time ago. The members of the staff at the District Irrigation Office report that the main factor limiting the government's power to enable the smallholders to have access to the water is the water permit belonging to the estate. However, it should be clear that the permit allows for the estate to use a maximum of 70 percent of the total canal flow at any time. The estate is, therefore, *not permitted* to abstract all of the flow at any time.

Other means of resolving the conflict are found in the Draft Water Bill, which requires that the holder of an irrigation permit must deliver unused water to the downstream users (MENR 2000, 35). Indeed, one of the fundamental principles of water management outlined in the Draft Water Bill is that "it shall be the duty of every person using water to exercise due care and diligence in order to avoid unnecessary waste and pollution (ibid)." The Draft Water Bill also provides for a range of means by which the water permit held by the estate could be varied or cancelled, with due compensation being paid.

The main factor preventing the MENR or other government institutions from resolving this dispute is the fact that the estate owner is a politician. It is not easy for a government employee to try to interfere in the business of a government politician. Possibly, the issue may best be tackled as part of a nationwide reassessment of water rights that predate a certain year. A reassessment of all rights granted prior to independence, for example, might allow for similar situations across the country to be tackled simultaneously, thus making it less of an “individual” issue.

### *Water Management Issues within Irrigation Schemes*

Water use in the irrigation schemes is controlled by a rotational system and farmers generally pay a fee of KSh 20 for a single irrigation “gift” (allotted irrigation slot, usually of a few hours’ duration). However, many of the group irrigation schemes within the division are affected by problems of water theft. Farmers with neighboring plots frequently breach the canal walls of the schemes to water their crops but do not pay any fee for this. In some cases, committee members themselves have also broken water distribution procedures. Therefore, it becomes very difficult to take action on this issue. In a typical scheme, bylaws specify a fine of KSh 1,000 for out-of-turn abstractions but these bylaws are not enforced. In one scheme, the same people had been on the Irrigation Committee for the last 10 years, having been reelected every 2 years. Normally, it is recommended that posts are changed frequently to avoid vested interests becoming entrenched in the management systems. While government policy is to promote the concept of gender balance, in most of the schemes, the female membership in committees is less than 20 percent.

All the irrigation schemes in the division have bylaws, regulating membership, water-distribution regimes, financial aspects and other management issues. Copies of bylaws of schemes are sent to the District Officer, the courts and the police. However, all of the irrigators interviewed during fieldwork complained of the difficulty of enforcing these bylaws.

The local chief complains that even if he takes those accused of water theft to court, they can be fined a maximum of about KSh 200, which is not a sufficient deterrent.<sup>23</sup> Members of the local administration also complained that the recent amendments to the Chiefs Act, which greatly reduced the powers of the chiefs, had impacted negatively on the capacity of the authorities to tackle water theft. Some of the respondents reported that the chiefs themselves frequently abstracted water illegally, thereby losing their credibility as enforcers of the bylaws. One irrigator lamented that “there is no support from the administration.”

The DIU is not in a position to enforce bylaws but it can offer management advice. However, this unit had not had a budget for fuel in the 6 months previous to the period of fieldwork. The last batch of fuel it received was just 20 liters.<sup>24</sup> This makes extension work, including monitoring of water-abstraction rates, very difficult. While farmers are willing to provide money for fuel for extension work it is unlikely that they would be willing to provide

---

<sup>23</sup>Interview with W. Lesilale, Chief, Kitobo Location, October 2000.

<sup>24</sup>Interview with Eng. Kinyanjui, DIE, October 2000.

fuel for activities such as monitoring of flows, etc., which would not directly benefit them. Irrigation schemes collect money for basic administrative and infrastructural expenses but they do not have separate funds to pay for extension services, which have been free in the past until the recent cost-recovery policies came into operation. For these to be made available for extension work, the district staff would have to demonstrate that their “investment” in extension work would be profitable. One way of benefiting the average irrigator would be to improve water-management procedures in the schemes, but this would often mean confronting the committee members who break the rules, and getting the support of other administrative staff who may also have direct or indirect interests in water theft.

## Conclusions

The case study has illustrated a number of important challenges to water management in Kenya.

- The uncertainty of government institutions over the acreage of irrigated land and the amount of water being abstracted is a result of the limited institutional capacity to gather and collate information on irrigation activities, largely due to financial constraints. Collection of basic data is a fundamental part of any water-management process in the district. There is a need for investment in monitoring systems, including funding for the transport necessary to gather information.
- This is just one instance of a general lack of state capacity to provide basic services in rural areas. Full or partial cost-recovery, using contributions from beneficiary communities, is now government policy. However, practical mechanisms for this are difficult to develop and enforce. Members of the local-level staff receive little support from district levels in implementing the policy.
- The MENR has become less capable of implementing or maintaining projects but the necessary support (e.g., training and encouragement) has not been given to the communities to take over these roles.
- Localized variation in water availability should be acknowledged in water-management plans, and current or potential future scarcity should be made apparent to all stakeholders. This is especially important in the case of members of the DDC who do not have a technical background in water management.
- The difficulties in enforcing bylaws of the irrigation scheme are exacerbated by frequent episodes of water theft by members of the committees and even by local administrative personnel, leading to a general breakdown in the enforcement of water-management regulations. Greater participation of a cross section of irrigators in development organs, such as the Locational Development Committees, may help empower the group members to change their committee members when necessary. When NGOs or government projects involve a capacity-building element, the training of a representative sample of the irrigators, rather than just committee members, may also help encourage scheme-level equality.

- The case of the sisal estate in Taveta may be affected by the proposed system of District Water Boards that represent more than one administrative district. This may help avoid political favoritism, as decisions would be taken by a group including government staff from the neighboring district. However, the power of political figures is such that they could influence these Boards by influencing higher political levels to pressure the decision makers. A massive change in the “culture” of governance would be necessary to avoid such situations, and this is a national, multi-sectoral issue.
- Finally, it is interesting to note that the DIU had not been involved in the formulation of the Draft Sessional Paper on Irrigation and Drainage, did not have a copy of it and had not been informed of its contents.

## **Next Steps in the Refinement and Implementation of the Water Policy and Water Law**

In the past, the Ministry-in-charge of water affairs has been highly centralized, resulting in a physical and psychological distance between Ministry staff and those they serve. This distance has discouraged long-term programs for community capacity-building and other initiatives from entrusting communities with responsibility for monitoring and management of water quality and quantity. For example, it does not have very effective links with community groups, especially when compared to the Ministry of Health. If it is to effectively implement the policies of participation and decentralization of responsibility, it should reassess and enhance its approaches to empowering communities. However, it should be recognized by the government and the NGOs alike that increased meaningful stakeholder participation often involves increased costs in terms of money and time. Participation also involves increased risk for the overseers of the management process because true participation leads to increased options and thus less certainty about the outcome. Unless meaningful support and power are given to community institutions, the current changes in the water sector will lead to a “vacuum” that will be filled by the most powerful actors to the detriment of the common Kenyan.

The twenty-five pieces of legislation that, in addition to the National Irrigation Board Act and the Water Act, have implications for water management, will have to be revised to harmonize with the statutes and the principles of the Water Act and the new irrigation policy. This could be done by involving a cross section of stakeholders in a focused workshop; it would also require sufficient political will to set a timetable for revision.

It is important that MENR establish means for conflict resolution between stakeholders. This is particularly important in the case of interbasin water transfers, seen by many in the MENR as vital for the economic growth of the drier areas of the country, because the River Basin Boards will have difficulty in agreeing with terms of transfer. Existing transfer projects have been characterized by lack of public accountability, debate and environmental-impact assessment.

Increasing involvement of stakeholders in policy formulation at all levels, from the division to the national level, will enable the government to benefit from enhanced legitimacy. It will then be in a better position to mediate in situations of conflicts in water use. However, specific training needs in the area of conflict resolution should be identified for key government

departments. Clearly, a “level playing field” does not currently exist, and processes should be developed to enable adequate representation of weaker stakeholders who have less bargaining power.

It is also necessary that government institutions improve the availability of information, so that people understand not only their rights but also the responsibilities they are asked to shoulder. Regulations need to be put in place for the dissemination of decisions made by the Water Boards and other important information. This process would be enhanced by improving links (both formal and informal) with stakeholders, at all levels.

At the local level, capacity building should be aimed at representatives of the beneficiary community, not merely the committee members. This is to ensure that the group understands the roles and responsibilities of each actor, those of the group members as well as those of the committee members. Participants of training courses should be selected by the community as a whole, and not merely by the committee or by the local elite.

The intention of the MENR to conduct nationwide workshops to foster “awareness creation and common understanding and interpretation of the policy at the grassroots level” (Wambua 2000) should be vigorously pursued. Workshops should be conducted in a participatory manner, and local-level staff should formulate the structure of the workshops, to ensure that they are motivated about the process. These workshops could be linked by common questions and gray areas to be resolved, and should involve a two-way debate, rather than a one-way process of “orientation” of stakeholders, controlled by the MENR.

It is planned that a summary of the Water Act be produced, in Kiswahili and possibly in some local languages as well as in English, for the benefit of the general population. Such a summary, or guide, will be an extremely useful tool for raising awareness and enhancing the capacities of local communities to monitor and manage local water uses. The guide to the Environmental Management and Co-ordination Act may provide a useful model for a comprehensive guide, which would focus on sustainable water use and ways for all stakeholders to gain equitable rights to water.

There is an inherent conflict between supply-oriented strategies of water development and exploitation, and approaches that are influenced by the concept of demand management and environmental conservation. The conflict between these two broad approaches is likely to be played out within the MENR, and will be implicit in different models for the restructuring of the Ministry. The supply-oriented approach prioritizes development of new water supply infrastructure and may involve interbasin transfers and other highly technical and capital-intensive projects. By its very nature, this approach requires the technical expertise that has been the core of the key institution within the MENR, the Department of Water Development. Therefore, the existing personnel have a vested interest in maintaining a supply-oriented approach, in order to protect their status within the MENR. For the same reason, it is in the interests of many MENR staff to resist decentralization of the various responsibilities of the Ministry. In many cases, the “lowest appropriate (institutional) level” for water management is the WUA. If the Ministry builds capacity amongst such decentralized management units, and hands over to them the responsibility for management, it is facilitating its own “downsizing.” Efforts must be made to restructure the Ministry in such a way that community links are prioritized and training for employees in relevant skills can assist them to find jobs in the NGOs and private sectors.

The demand-management approach emphasizes increased efficiency in water storage and distribution, application of charges for water abstraction, conservation of watersheds and the use of other environmentally sound practices such as on-farm soil-and-water conservation

and rainwater harvesting. It also requires difficult trade-offs to be made between different water uses, trade-offs that have political implications. These strategies require an improved degree of stakeholder participation, awareness-raising campaigns, and unprecedented levels of coordination with other institutions. The equitable and sustainable allocation of water resources also requires considerable political will.

## Literature Cited

- Anonymous. 1999. Kilifi District Development Programme—Project Appraisal and Consultancy (Draft). Internal document for KDDP. Duplicated.
- Arntzen, Jaap. 2000. Sustainable water management in Southern Africa: An economic perspective. Paper presented to the Workshop on Freshwater Resources in Africa, 26–30 October 2000, UNEP, Nairobi.
- Barrow, Edmond. 1996. *The drylands of Africa*. Nairobi: Initiatives Publishers.
- de Villiers, Marq. 1999. *Water*. Toronto: Stoddart Publishing Co. Limited.
- FAO (Food and Agriculture Organization). 1995. *Aquastat*. <http://www.fao.org/waicent/FaoInfo/Agricult/AGL/AGLW/aquastat/kenya.htm>
- Hai. 1998. *Water harvesting*. RELMA Technical Handbook No. 16. Nairobi: Regional Land Management Unit.
- Hamman, R.; and T. O' Riordan. 2000. *South Africa's policy transition to sustainability: Environmental and water law*.
- ICID (International Commission on Irrigation Development). Kenya. *Website*.
- IDB (Irrigation and Drainage Branch). 1994. *District profile: Taita/Taveta district, coast province*. Kenya: MoA, Livestock Development and Marketing.
- Kimani, J. K.; and J. O. Otieno, eds. 1992. Which way irrigation? In *Proceedings of a National Workshop (26–29 May 1992)*. Netherlands: Ministry of Planning and Development/Government of the Netherlands.
- Kunzi, Erwin; Yvan Droz; Francisca Maina; and Urs Weismann. 1998. Patterns of peasant livelihood strategies: Local actors and sustainable resource use. *Eastern and Southern Africa Geographical Journal* Vol.No.8. (Special Number).
- MENR (Ministry of Environment and Natural Resources). 2000. Draft Water Bill 2000, Internal document. Duplicated.
- MoA (Ministry of Agriculture). 1998. Sessional paper on irrigation and drainage development in Kenya (Draft). Duplicated.
- MoA/KARI (Ministry of Agriculture/Kenya Agricultural Research Institute). 1987. National irrigation and drainage research project. Internal report.
- MoWD/JICA (Ministry of Water Development/Japan International Cooperation Agency). 1992. *The study on the national water master plan, executive summary*. Kenya: Government of Kenya.
- MoWD (Ministry of Water Development). 1999. *Sessional paper number 1 of 1999 on national policy on water resources management and development*. Nairobi: Government Printers.
- Mwongera, E. K. 1996. Overview of water resources management challenges in Kenya. In *Seminar on integrated water resources management in Kenya: Proceedings*, ed. R. Hirji, F. M. Patorni and D. Rubin. Washington, D.C.: The Economic Development Institute of the World Bank.
- National Steering Committee, World Day to Combat Desertification. 2000. Commemoration of the World Day to Combat Desertification (WDCD) on 17 June in Taita-Taveta District, Annex II. Duplicated.



- Ramazzotti, Marco. 1996. *Readings in African customary water law*. Rome: Food and Agriculture Organization.
- Sanyu Consultants Ltd. 1999. *The study on community-based small holder irrigation development project for promotion of horticultural production in the foothills of Mt. Kenya*. Japan International Cooperation Agency/MoA.
- Scoones, I. 1992. *Wetlands in drylands: Key resources for agricultural and pastoral production in Africa*. 2nd edition. Issue Paper No. 38.
- Sottas, B.; G. K. King'oriah; C. Eggman Betschart; E. N. Ndegwa. 1998. Dilemmas of deciding stakeholders: Governance and open access to common property. In *Eastern and Southern Africa Geographical Journal* Vol. 8. (Special Number, September 1998).
- Southgate, C.; and D. Hulme. 1996. *Land, water and local governance in Kajiado: A district overview*. Manchester, UK: Institute of Development Policy and Management, University of Manchester.
- Thuo, Simon. 2000. Private sector participation in the national water policy as relates to poverty eradication. Paper delivered at the National Workshop on Water Legislation and Policy as Relates to Poverty Alleviation, KCCT, Nairobi, Kenya, February 2000.
- UN (United Nations). 1989. *Groundwater in eastern and southern Africa*. New York: UN Department of Technical Co-operation for Development, Natural Resources/Water Series No. 19.
- Wambua, Samuel. 2000. A paper on community water supply management. Paper presented at the "Workshop on Water Policy as it Relates to Poverty Alleviation," Kenya College of Communications Technology, 2–4 February 2000.
- World Bank. 1993. UNDP/World Bank Water and Sanitation Programme. website. <http://www.wsp.org/English/index.html>

## Part 5

### Regional Relevance



# Relevance of Kenyan Irrigation Experience to Eastern and Southern Africa

*N. Hatibu, H.F. Mahoo and O.B. Mzirai*

## **Introduction**

### ***Why Irrigation?***

Most documents about agriculture in sub-Saharan Africa will normally have at least a sentence complaining that there is very little irrigation and that only about 5 percent of the irrigation potential is being exploited. However, despite its high profile, irrigation is only one method of managing the water available to plants. Consequently, the issue should not be how many hectares are under irrigation, but how many hectares get optimal amounts of water to meet crop needs throughout the growing season. The water can be supplied directly by rain or through irrigation. Planning for irrigation by a given farmer in a basin or a country should, therefore, be preceded by efforts to maximize and optimize the use of direct rainfall. This is especially important in cereal production systems in sub-Saharan Africa, for which irrigation often gives low returns and low profitability (FAO 1986, 48).

The point being emphasized here is that major improvements in cereal production in sub-Saharan Africa can be achieved by increasing the amount of biomass produced per unit of water used, under both rain-fed and irrigated farming. Further, irrigation should be designed for the purpose of enhancing water available for crop production only after direct rainfall has been used effectively. This point has been made before. For example, the FAO (1995a, 1) stated that adoption of the improved water-conservation technology in the Central Great Plains of the USA made the largest single contribution (45%) to the increase in average wheat yields from 750 kg/ha to 1,800 kg/ha from 1936 to 1977. This was ahead of improved varieties (30%), equipment (20%) and fertilizer practice (5%).

The concept of increasing the effectiveness of water use is also a major concern in irrigation. For example, Scheltema (2000) refers to the concept of tail-to-mouth approaches to rehabilitation of irrigation schemes. The basic principle of this approach is that farmers have to improve the efficiency of using the little water they have before efforts are made to increase the amount of water reaching the field. This emphasizes that, to be effective and profitable, irrigation should not do what can be achieved with direct rainfall but should rather supplement/complement and extend the productivity of rainfall. A field that cannot use rainwater effectively will rarely use irrigation water efficiently. In many farming systems, more than 70 percent of the direct rain falling on a crop field is “lost” as nonproductive evaporation or flows into saline sinks. In extreme cases, only 4–9% of rainwater is used for crop transpiration (Rockström et al. 1998).

Irrigation is one of the management tools available to farmers when combined with other tools and inputs enabling them to maximize productivity and profit. One vital role of supplementary irrigation, for example, is to even out the poor distribution (both spatial and temporal) of rainfall that often makes rain-fed farming a high-risk business. With irrigation to reduce the risk, a farmer can afford to invest in other inputs (e.g., fertilizer, improved seeds, etc.) for intensive production, but such inputs are also costly. Using these inputs without improved water management exposes the farmer to a big loss in case of drought at a critical crop-growth stage.

Since most of the countries in the region are adopting free-market economic systems, the extent and choice of irrigation should be demand-driven. This means that commercial requirements should guide farmers, communities and even countries to choose the type and extent of irrigation that is most suitable for their circumstances and businesses. This is a radical step given the recent history of irrigation development in sub-Saharan Africa, where governments have used irrigation as a tool for achieving social goals with very little economic considerations. Reasons for irrigation development have included attempts to achieve food self-sufficiency and security, creation of employment, establishment of settlements and boosting of foreign-exchange earnings. The governments have enacted policies that stipulate by how much, and by what means, irrigation will be developed in a country. Irrigation was supply-driven rather than demand-driven, and failures, such as that represented by the Bura irrigation scheme in Kenya (see under *Private investment*, 316) are consequences of this policy.

At this point, it is important to emphasize that the large public-irrigation schemes, which made news by failing miserably, are not the whole story of irrigation in the region. There are examples in all the countries reviewed in this paper of very successful large and small commercial irrigation schemes. Therefore, the review of the changing face of irrigation in the region, with special focus on Kenya, has come at the right time. It will provide an opportunity to learn from both failures and successes so as to properly guide the ongoing privatization and commercialization of the irrigation subsector in the region.

### ***Status of Irrigation in the Case Study Countries***

Examples from five countries in the region were selected to compare and assess the relevance of the Kenyan irrigation experience to eastern and southern Africa. The five countries, Sudan, Ethiopia, Zimbabwe, Mozambique and Tanzania, provide different frameworks on which to extrapolate the experience from Kenya. The region also provides an attractive possibility of developing irrigation to meet regional needs rather than local food self-sufficiency. If countries, basins or households can be freed from the need for food self-sufficiency, then water resources and irrigation can be directed to areas of best economic use and comparative advantage.

The selection of Sudan was based on the fact that it has the largest irrigated agriculture and perhaps the longest experience, in the region. Irrigation has been practiced in Sudan since ancient times. Over 25 percent (1.75 million hectares [M ha]) of the cultivated land (7.6 M ha) is irrigated using free-flow open channel systems. Most of the water is obtained from the Nile

but in the north of the country, irrigation depends on groundwater in about 12 basins. Although small private irrigation schemes exist especially for the production of horticulture, large-scale schemes with tenant farmers are still the main approach to irrigated agriculture in Sudan (USAID 1982, 5). Therefore, it can be said that irrigation in Sudan is dominated by a few with very large irrigation schemes. These are the Gezira (468,00 ha), Managil (379,000 ha), Khashm Al-Girba (164,000 ha), Rahad (126,000 ha), Essuki (37,500 ha), Guneid (35,700 ha) and Kenana (33,000 ha) (FAO 1986, table 15). Several studies have shown that returns from irrigation in Sudan have been far below the potential (World Bank 1990). Examples from Sudan are based on a desk review of literature prior to 1990. Unfortunately, we do not have current information on the status of irrigation in Sudan.

Ethiopia was chosen because of its unique location at the upstream end of the Nile basin. It is estimated that about 90 percent of the annual runoff in Ethiopia flows into neighboring countries through 11 rivers. Therefore, development of irrigation in Ethiopia would have international implications of a large magnitude when compared to Kenya where the major rivers flow into the ocean. However, irrigation is very limited in Ethiopia and it is estimated that only 2 percent of the cultivated land is irrigated (Baecher et al. 2000).

Zimbabwe can be compared to Ethiopia in terms of its location in the Zambezi river-basin system, but also more closely with Kenya, in terms of the characteristics of the agriculture sector. Zimbabwe's irrigation is however more developed and capital-intensive than in the other two countries. The most interesting aspect of irrigation in Zimbabwe is the dominance of private, large-scale commercial farms. Out of the 150,000 hectares estimated to be under irrigation, 126,000 are said to be large-scale commercial farms (Mazungu and der Zaag 1996, 1). Another interesting aspect is the extent of investment in water-storage reservoirs for irrigation. It is estimated that there are over 6,500 reservoirs of various sizes in use in the country (ICID, Website).

Mozambique has been included because of its downstream location to several international river systems, including the Ruvuma, Zambezi and Limpopo. Only 50 percent of the surface water is generated internally. One of the most interesting aspects of irrigation in Mozambique is the low utilization of water for irrigation from existing large dams. The country has more than 10 large dams with a total storage capacity of over 50 billion m<sup>3</sup>. Only 9 percent of the stored water is utilized for irrigation.

Tanzania was selected because it has a large number of irrigation schemes (estimated to be more than 600) of various sizes. Official statistics show that the irrigated area in Tanzania is about 150,000 hectares of which 120,000 hectares are made up of approximately 100,000 smallholdings, each less than 5 hectares. About 25,000 hectares are large, centrally managed irrigation schemes (MoFA and DANIDA 1997, 1). An interesting aspect of irrigation in Tanzania is that major schemes are located upstream of hydropower plants in the Pangani and Rufiji basins.

### ***Purpose of the Paper***

The aim of this paper is to synthesize the findings from the Kenyan case studies in the context of eastern and southern Africa. The paper summarizes key issues related to irrigation transformation as identified in the Kenyan case studies. This is followed with an evaluation

of the relevance of these issues to the case-study countries. Finally, the paper attempts to identify key lessons and research areas for consideration in the ongoing restructuring of the irrigation sector in the region.

## **Methodology**

The approach consisted of a review of all the Kenyan case-study papers and identification of key issues in the process. The next step was the collecting and reviewing of relevant documents on irrigation in the selected case-study countries. A substantial amount of information was obtained through the Internet. In the case of Tanzania, in addition to a review of literature on irrigation development of the country, limited firsthand information was collected from several schemes. This included field visits to the Lower Moshi irrigation complex, which is in the foothills of Mt. Kilimanjaro. There are two main irrigation schemes in the complex. The next area investigated was the Usangu complex on the upper end of the Rufiji basin. There are three major irrigation schemes in the Usangu complex. These are Kapunga, Madibira and Mbarali irrigation schemes. The third area was in the Morogoro region where it is estimated that 50 percent of the irrigation potential (23,350 ha) has been exploited. Several irrigation schemes including the Dakawa rice farm were assessed for this review.

## **Results and Issues**

### ***Database on Irrigation***

Two issues on irrigation databases clearly emerge from the Kenyan papers. First, data are available only in a small amount and is of low quality. Second, improvement of the quantity and quality of the available data and their effective utilization are constrained by technology and low priority accorded to the building of databases. This situation is not unique to Kenya but is common in all the countries reviewed in this paper. One example of the poor quality of data is given by the variation in published data on irrigation potential of different countries (table 1). The development of a meaningful database requires an agreement on definitions of the most important aspects. The example given in table 1 is a result not only of the poor data collection but also of the lack of common definitions of what irrigation is and what determines irrigation potential in a given area. Data on actual irrigated area are also poor because there is no common understanding of irrigation scales or differentiation between supplementary and dry-season irrigation.

### ***Lack of common definitions***

Irrigation is generally defined as artificial application of water to land to sustain plant growth (Withers and Vipond 1974). Others define irrigation as the supply of water to agricultural crops by artificial means, designed to permit farming in arid regions and to offset drought in semiarid regions (FAO 1997). Stern (1980) defined irrigation as any process, other than natural

*Table 1. Differences in the estimation of irrigation potential ('000 ha) of a country by different organizations.*

Source Country	National Ministry	Other National Agencies	FAO	IFAD	WB	AQUASTAT	
Ethiopia	2,300	2,700	3,500	670	2,800	1,500	3,637
Kenya	540	390		350		245	
Mozambique				2,400			3,300
Sudan				3,300			4,842
Tanzania				2,300			829
Zimbabwe				280	150		

precipitation, which supplies water to crops, orchards, etc. However, given the role of new technologies and environmental concerns, these definitions are not comprehensive enough. Therefore, irrigation should be defined as any process other than direct rainfall, which adds water in a cost-effective way to the soil to maintain optimum Plant Available Water (PAW) and aeration in the root zone of a given crop, without degrading the soil in the long run.

### *The issue of scale*

In reference to size of irrigation schemes, the terms “large scale,” “medium scale” and “small scale” are used without any agreement on what makes an irrigation scheme or activity large or small. Table 2 shows how the reviewed countries differ in their definition of different scales of irrigation. This is an example of the difficulties of using the concept of size at global level. What is large in one region may be micro-scale in another. This is an important issue when international organizations attempt to develop programs and guidelines for a certain scale of irrigation, often small-scale.

There is some confusion regarding the size of a scheme and the size of a plot under a single irrigator. The tendency has been to consider schemes with many irrigators as small scale. For this reason many large-scale irrigation projects have been called small scale on the basis of the size of plots per farmer. Consequently, until recently, truly smallholder irrigation has not been recognized, and is often missing from irrigation statistics. Irrigation officials in different countries are now calling the truly small-scale irrigation schemes, traditional irrigation (Mrema

*Table 2. Differences between countries and international organization in determining the scale of irrigation.*

Country Scale	Ethiopia	Tanzania	Mozambique	FAO
Large (ha)	>3,000	>2,000	>200	> 500
Medium (ha)	200–3,000	400–2,000	30 –200	50–500
Small (ha)	<200	<200	<30	< 50



1984, 309–310). In Zimbabwe, small-scale irrigation has been called “informal irrigation” (Mazungu and der Zaag 1996). There is another scale, which is too small to qualify as small scale, which is that given in the paper by Sijali and Okumu (2000, 2). Many of the individually operated irrigation systems, most of which predate the so-called “formal” irrigation, are designed to irrigate less than 1 hectare of land. Similar to what has already been explained regarding small scale, the micro-scale systems have been largely neglected in official statistics and have received only a minimum of inputs in terms of investment, research and extension.

### ***Supplementary v dry-season irrigation***

Supplementary irrigation is defined as the application of an extra amount water during the rainy season over and above that supplied by direct rainfall in order to optimize water available for plant growth (Oweis et al. 1999). Dry-season irrigation is a system of irrigation designed to provide enough water to raise a crop even when there is no direct rain. Supplementary irrigation is often designed to capture water directly from a river or flood-flow, with a limited control of the water availability in both quantity and timing. Therefore, there are seasons when the water is inadequate and only part of the command area gets water for irrigation while in other years, the water may be in excess, and drainage becomes important.

Nearly 80 percent of irrigation in Tanzania is supplementary (MoAC 1999) where there are no water-storage systems. Even Sudan, with a high level of water management in irrigation schemes, has over 100,000 hectares under supplementary irrigation in the Gash and Tohar deltas. On the other hand, in Zimbabwe nearly all the major irrigation schemes have reservoirs for water storage as part of the system (ICID, Website)

### ***Public v private irrigation***

Another area of definition that will soon be causing confusion in the interpretation of data is the differentiation between public and private irrigation schemes and projects. It is most likely that the privatization process will lead to a situation where both public and private interests are involved in an irrigation scheme. There is, therefore, a need to develop a common definition and demarcation between public and private schemes. The FAO Investment Centre (1995) proposes the following definitions: a) Public irrigation is where the government, directly or through agencies, has the dominant financial interest or management/control. b) Private irrigation is where private individuals (e.g., farmers) or groups (e.g., companies) have a dominant financial interest and carry the risks.

### ***Accuracy of data***

Current data on irrigation in most countries are basically guesswork. There is an urgent need for an agreed common approach for assessing irrigation potential, so as to facilitate a reliable review of the data currently being quoted. In many cases, land suitability is the only criteria used (FAO 1986, 14). However, in reality, water availability and soil resources would be better measures of irrigation potential (FAO 1995b, 325). The question is how this can be done. Further,

the final determinant should be technology and socioeconomic infrastructure available to support irrigation. As more efficient technologies are adopted, some land constraints could be overcome thus making efficient technologies the determinant of maximum irrigation potential (FAO Website).

Data on actual irrigated area in the reviewed countries are also doubtful. This is because, as shown in this section, it is not clear what type (supplementary or dry-season) and which scales are counted. Similarly, most of the micro-scale and some of the small-scale (traditional or informal) schemes are not counted [box 1]. In general, data on irrigation in most of the countries require major and urgent revision.

### ***Resources, Adequacy and Tenure***

From the Kenya case study papers, many issues related to resources, adequacy and tenure have arisen. These include the following:

- skewness in spatial and temporal distribution of rainfall

#### *Box 1. "Traditional irrigation" in Tanzania.*

It is estimated that furrow irrigation on the highlands of Tanzania dates back to more than 2,000 years. A survey conducted in 1987 showed that vegetables supplied to major cities and towns in Tanzania came from land irrigated by these ancient furrow irrigation systems. Most of this irrigation does not show up in official statistics. The most prominent highland districts in Tanzania with hillside irrigation include:

- Lushoto
- Same
- Mwanza
- Arumeru
- Iringa
- Kilosa
- Bukoba

It is not known how many hectares are under furrow irrigation in these districts.

- shortage of water available for effective use
- unclear ownership and access to water
- poor definition of landownership
- obsolescence of the tenancy system
- poor land management

### ***Skewness in spatial and temporal distribution of rainfall***

Given that rainfall is the ultimate source of water, the skewness of rainfall is a major problem facing irrigation development across the region. This problem is of regional scale in that the southern subregion including countries such as Zimbabwe, Mozambique, Republic of South Africa and Namibia have low rainfall compared to the eastern subregion (Malawi, Zambia, Democratic Republic of Congo, Rwanda and Burundi). The amount of rainfall also decreases rapidly northwards as one crosses the equator, Ethiopia being the exception.

There are two important implications of skewness in the availability of the water resources. The first is the need for long-distance transfers of water from points of source to the points of use. This becomes complicated where the two points are in different countries. The second is the need for large storage facilities, so as to reserve rainwater, which is available during a short time of the year, for use during periods of unavailability. Both approaches require high investments in capital. Often, payback from irrigation is considered inadequate to justify the high capital investment. Hence, many storage dams in the region have been constructed mainly for the generation of electrical power. Generally, major water transfer schemes are constructed to supply water for domestic and industrial uses although Sudan is an exception.

### ***Ineffective use of available water***

Recent writings on water as well as several of the Kenyan papers (Mati 2000; Ngigi 2000a, b; Huggins 2000; Gichuki 2000) present a view that there is scarcity of water in general and for irrigation in particular (Seckler et al. 1999, 1; Barker and Van Koppen 1999, 1). But when viewed from the point of view of quantity of rainfall at country or regional level, there is plenty of water. Seckler et al. (1999, 8) state that at global level, water is the ultimate renewable resource. One uses all of one year's supply and then, on average, the same amount is available for use the next year. The problem is that the water is available only for a short duration and sometimes only in a few areas. So what is scarce is rather not water but technologies for overcoming poor spatial and temporal distribution.

Inadequate conservation of rainwater is a result not only of shortage of storage infrastructure but also of degradation of soil, which is a natural storage medium. Poor land use is rapidly reducing the capacity of soil to store water in readily available form, so that rainwater rapidly evaporates back to the atmosphere or quickly flows to saline sinks before it is put to beneficial use. Another consequence of destroying the capacity of soil to store water is that groundwater is often depleted due to inadequate recharge.

Supplementary irrigation can be designed to exploit water that floods plains during the rainy season. An example of this approach is the irrigation schemes in the Usangu plains of Tanzania. It is estimated that most of these schemes are utilizing water that, in the past, flooded the plains and was lost by evaporation. Preliminary data show that, during the growing season, these schemes take very little water away from downstream users (MoW 2000, 66).

### ***Ownership and access to land and water***

The concept of water as a public good and free access to water as a human right is the cornerstone of water resources policy and management strategies all over the world. Although it is difficult to see a viable alternative to this approach, this concept is a source of many problems associated with ownership and accessibility to water. In all countries in the region,

water essentially belongs to the state with specific water rights/permits being issued for limited amounts and periods to individuals and companies. The approach can be termed a short-term privatization of limited amounts of water to individuals and private groups.

Landownership and tenure in the majority of the countries in the region are governed by national land policies whereby land is public and vested in the President as a trustee. This implies that for the majority of smallholder farmers, landownership (and access to water) is highly insecure and fluid. Consequently, farmers are vulnerable to influential and powerful politicians as illustrated in the case study given by Huggins involving the Njoro Kubwa, the Kitobo and the Kamleza irrigation schemes in the Taveta division. Most literature on ownership and tenure emphasizes that there is a need for tenure security and that various types of tenure can be secure or insecure depending on social, legal and administrative institutions in a given society (FAO, Website).

### ***Tenant-farmer system***

The tenant-farmer system is common in the region, especially in Sudan. Each of the large schemes is managed by a public Agricultural Corporation, which makes all decisions and controls the provision of all services. The development of irrigation infrastructure up to the main canal level is the responsibility of the Ministry of Irrigation and Water Resources (MIWR). The agricultural corporation supervises the O&M of minor canals as well as the production units. If the water is from groundwater resources, then the Groundwater Corporation is responsible for its delivery to the minor canals. Tenant farmers are responsible for paying costs of all agronomic operations, which are also provided by the Agricultural Corporation. Farmers are allowed to keep only 49 percent of the net income from cotton.

The case of Mwea, so well described by Kabuta and Mutero, has shown that the tenant farmer system of providing land and irrigation services to farmers is now obsolete. The absolute control over all aspects of economic as well as over some aspects of the social lives of the tenants is obviously unacceptable in this era of democracy and freedom for individuals. In Zimbabwe, Mazungu and der Zaag (1996) observed that the economic control in smallholder schemes is such that the tenant farmers are not very different from employees of the government or irrigation institutions, the only difference being that the remuneration of farmers did not come in the form of a regular wage. After studying the tenant system in Sudan, USAID (1982) concluded that “the tenant farmer faces a dual role as a farmer and an employee, but has little role in the decision-making process, contributing to low productivity.” An alternative is urgently needed in nearly all countries.

### ***Land management***

Ong and Orego (2000) provide a very good case study of the major threat to irrigation schemes in the region and perhaps all over the world, due to environmental degradation. Damage to sources of water and irrigation schemes as a result of pollution, soil erosion and other land and water-degradation processes, is a major threat to the sustainability of irrigation systems.

Siltation of crop fields, canals and water reservoirs is perhaps the leading problem and threat to irrigation schemes everywhere. As a result, schemes are often reported to operate at less than 50 percent capacity and reservoir storage is quickly lost (Murray-Rust 1973, 334). The removal of silt from canals and reservoirs is, in many cases, a major cost item of

the O&M budget. Often, the process is not implemented fully due to the inefficiency of public institutions managing the canals. Consequently, there is a continuous annual shrinkage of the irrigated area leading to eventual abandonment of schemes. These problems are common in the region. For example, in Sudan, the main reasons given for poor performance of irrigation are high costs of clearing silt from canals, reduction of canal capacity caused by weed growth, and high loss of water from reservoirs, especially by evaporation.

The problem lies in the poor management and conservation of the catchment area, especially where it is under cultivation. Unfortunately, for a long time now, thinking on land conservation has been dominated by forestry. Therefore, in many cases, deforestation is cited as the main cause of soil erosion and depletion of water resources. However, research has started to show that:

- forests are net consumers of water (Calder 1994),
- generally, in countries such as Tanzania, most of the land is under forest, woodland or bush cover, and
- land that is well managed under grass cover yields more water for a longer period after rains than a forested area (Hornung and Newson 1986, 62).

Therefore, the issue may not be deforestation as often argued, but poor management and conservation of land once it has been cleared of forests and put into other uses, especially crop cultivation (EAAFRO 1979).

### ***Irrigation Technologies***

It was suggested, in this paper (see under *Database on Irrigation*, 306), that technology is an important component in the determination of irrigation potential and its successful exploitation. There are three major issues related to irrigation technologies. The first is the need for technologies to improve water availability and use efficiency. The second is the establishment of institutional arrangements for technology development and transfer to ensure that appropriate technologies are available to the farmers. The third is the issue of O&M of infrastructure and machinery.

### ***Improving availability and productivity of water***

In the region, irrigation is dominated by the classical approach of flooding the land to saturate the entire root zone at particular intervals. Often, the application schedule is designed so that the water in the soil is completely depleted before the next application. Alternatives to this wasteful practice are available but they continue to be ignored because most of the new techniques do not conform to the training and understanding of irrigation by current planners, designers and engineers (Lambert and Faulkner 1989).

Water storage is a challenging area for technological development, since current approaches to water storage are very expensive. Storage of water is common and widely practised in southern Africa, significantly in South Africa, Namibia and Zimbabwe. Poor development of groundwater limits the exploitation of the “free” storage capacity provided

by the earth's crust. Often, groundwater-development schemes are concerned more with water abstraction with minimal deliberate efforts to recharge the aquifers.

A higher potential for expanding production under irrigation lies with technologies for increasing the productivity of water. The purpose is to optimize growing conditions for crops as well as to minimize soil degradation in the long term. The amount of control is low in rain-fed farming, minimum in flood irrigation and maximum in controlled environment farming, such as greenhouses. Technologies for achieving high levels of control are already available. One example is the technique that uses high frequency, low volume, partial-area application of water and nutrients to crop fields (FAO 1997). These techniques need to be adopted in sub-Saharan Africa. However, there are serious obstacles against a wider-scale adoption of technologies for efficient irrigation. One of the obstacles is the lack of incentives among farmers to invest in water-efficient systems. The principal causes of this problem have been already discussed (see under *Ownership and access to land and water*, 311) in relation to low price of water and poor enforcement of water permits. To control wasteful uses of water through pricing mechanisms there is an urgent need to foster attitudinal changes in putting a value on water.

Further, effective irrigation is not only a matter of water-application hardware but also an outcome of the value of the products being produced. Therefore, productivity of irrigation water can be enhanced by switching to high-yielding and high-value varieties of crops. However, the option has its limitation due to the current concerns about food sufficiency and security as well as limited markets for high-value crops.

### ***Technology development and transfer***

Poor research or lack of research, training and extension services hinders irrigation development, to a great extent, in most of the countries covered in this review. In Tanzania for example, research on irrigation is almost negligible. Apart from inadequate research and development, most countries in the region have little or no local irrigation industry dealing with the manufacturing, distribution and servicing of irrigation equipment. Further, due to the long-term dependence of foreign firms for the construction of irrigation infrastructure, the local engineering and construction firms have very little experience with irrigation.

### ***Operations and maintenance***

Perhaps the weakest links in irrigation systems of most countries reviewed in this paper are O&M. There are generally four main causes to this problem. The first is poor feasibility, planning and design (especially choice of technology) of many projects. The second is the weak management structure and capacity of public or private O&M institutions as well as of farmers themselves. The third is shortage of funds either because the farmers are making very little and are thus unable to pay or that they are unwilling to pay because the service is very poor or they have not seen benefits from previous payments. The fourth is the problem associated with rapid siltation of canals due to poor management of catchments.

O&M problems are common for all the irrigation technologies available. However, poor O&M are frequent and have more drastic effects on mechanized systems, which normally have low tolerance to poor maintenance. According to Scheltema (2000, 16) findings in Kenya show that the management of a pump-fed system by a group is often beyond the capability of

the farmers' community. The same is made clear by the case study from Zimbabwe (Matsika 1996, 39) given in box 2.

### ***Mode of Ownership and Management***

An irrigation system involves many subsystems and the most important include:

*Box 2. The Zimbabwe case study.*

The Mundotwe irrigation scheme is pump-operated and practices communal irrigation among its beneficiaries. In 1994, the pump broke down in the middle of the wheat season, and the irrigators had no money to repair it. They approached the District Development Fund (DDF) for services. Many irrigators prefer the DDF because it does not charge transport and labor costs. Unfortunately, DDF had no funds (the fund allocation for this project had been exhausted). The irrigators had no choice other than to go to a commercial firm. Through the commercial firm the pump was repaired but since the farmers had no cash to pay, they had to take a loan at 32 percent interest.

a) The water subsystem

- the water resource (surface or subsurface)
- means of abstraction
- infrastructure for transporting and delivering the water to the irrigated farm, including storage
- systems for water application and spreading on the farm
- structures for drainage and disposal of any excess water

b) The agricultural subsystem

- agricultural land
- machinery and other production hardware
- farm structures other than those for managing water

c) The market subsystem

- input supply

- processing infrastructure
- means of transportation

In relation to the mode of ownership, three important issues were raised in the Kenyan case studies. These are types of ownership, role of key players and private investment. This section discusses these issues using examples from other countries in the region, and makes suggestions on how problems related to ownership and management can be overcome.

### ***Types of ownership***

Private ownership of irrigation facilities, especially by individuals or companies, is the most common mode in southern African countries of Zimbabwe and South Africa. For example, in Zimbabwe about 89 percent of the reservoirs are privately owned. Further, in South Africa, full privately owned and managed irrigation schemes are common for all crops and all sizes. At the same time, in countries like Tanzania, privately owned large-scale irrigation schemes are limited to estate farms for commercial export crops, such as tea and sugarcane. Large-scale irrigation of food crops is normally dominated by publicly owned irrigation schemes. These are either parastatals or large-scale smallholder systems normally referred to as Farmer-Managed Irrigation Schemes (FMIS). The exception to this is found in Sudan where large FMIS are involved in the cultivation of cotton.

The technology choice has a very important influence on the mode of ownership and vice versa. For example, gravity-fed furrow or flooding systems tend to require public or group ownership. At the same time, pump systems tend to work better under individual ownership, with numerous instances of failure under public or group management.

### ***Management and the role of different players***

Irrigation, especially by smallholder farmers, involves many key players. This complicates management, especially O&M of irrigation infrastructure. Under parastatal or large-scale or estate farms, management should be straightforward, due to full ownership of the whole system. With smallholder farmers the situation is different since different subsystems are often owned and managed by others. In this case, the most important players are:

- government agencies, donors and NGOs that normally provide for the construction of the infrastructures as well as their O&M
- farmer groups, associations and cooperatives that may operate and maintain several subsystems
- service providers who may provide whole services and specialized technical inputs such as repair of pumps
- traders who often deal with equipment and input supply, transportation, processing and packaging as well as marketing of produce
- large-scale farmers or companies that may provide certain services to smallholder farmers (see box 1)



In many countries, farmer-support systems are underdeveloped and there is no clear demarcation of roles for the different players. Most irrigation schemes are dominated by a management approach where a single parastatal company or farmers' organization attempts to control all aspects of production and marketing under irrigation.

The trend to privatization involves the transfer of entire management of large irrigation schemes to private companies or WUAs. It would, for example, be difficult for a WUA or farmer cooperative to take over large irrigation schemes as is being attempted in the Mwea irrigation scheme. In his paper Gichuki describes the success story of Homegrown (K) Ltd., which is a private company operation, that has total control of ownership, management, production and marketing.

In many cases, farmer management is not likely to do much better than the parastatal management. This is because it is difficult for a single company to exploit economies of scale while dealing with different business areas and modern technologies, which require a high degree of specialization. On the other hand, there is unwillingness among irrigators to leave several subsectors to others due to inadequate regulatory mechanisms for ensuring that each player deliver as expected. There is a shortage of good examples where private or public O&M service providers have performed to the satisfaction of the farmers and other players. Poor O&M services lead to low performance of the system and low crop returns for the farmer. These result in a vicious circle common in many community irrigation schemes, the circle of poor O&M→low production→low profit→inability to meet O&M costs→poorer O&M.

### ***Private investment***

In this paper we briefly attempted to differentiate between private and public irrigation schemes (see under *Public v private irrigation*, 308). The era of fully public schemes where the government plans, finances and implements irrigation projects is gone. These kinds of schemes have tended to give irrigation, in general, and large schemes, in particular, a bad name (box 3). Therefore, full or partial private ownership of irrigation schemes appears to be the vogue for the future.

There is already a substantial amount of private investment in irrigation taking place in the region. Most private investors, except in South Africa and Zimbabwe, have invested in irrigation schemes for traditional cash crops such as tea and coffee. Recent investments,

#### ***Box 3. The Bura disaster (after Gunnell 1986).***

The Bura Irrigation and Settlement Project (BISP) is located downstream of the Kiambere dam in the Tana river basin. It was initiated by the Government of Kenya in the 1980s with a World-Bank-loan and other donor support. After spending more than US\$100 million, the project managed to put a maximum of 6,000 hectares under irrigation. However, the whole project has now totally collapsed because the soils were proven unsuitable for the type of irrigation that was being attempted. The only remaining outcome of all the investment comprises the settlers who are now living in abject poverty and are dependent on food handouts. Even water for domestic use has become a problem.

notably in Kenya, have been in high-value export crops such as vegetables and flowers. It is now estimated that about 40 percent of irrigated land in Kenya is in private hands.

Trends in private irrigation, at least in Kenya and Tanzania, show that most of the investment has been in market-oriented production. Most of the private, large-scale irrigation is found in coffee, tea and sugarcane estates. In Tanzania, for example, there are 4,500 hectares of tea estates under irrigation. Smallholders have often invested in irrigation for vegetable production. Box 4 gives examples of small-scale irrigation development in Tanzania through private investments.

The low inclination by the private sector to invest in irrigated production of cereals is clearly shown in the failure to privatize irrigated maize and rice parastatal farms in Tanzania.

*Box 4. Night storage for equitable distribution among highland and lowland irrigators.*

The same District in Kilimanjaro region (Tanzania) comprises highlands and lowlands (eastern and western). Whereas the highlands are endowed with streams and rivers and are relatively wet, the lowlands, especially the western lowlands, are semi-arid. During dry seasons, farmers/irrigators in the highlands utilize almost all the waters in the streams. As a consequence, the lowland farmers get no water at all. This situation has become a source of conflict between the two groups of farmers. To solve this problem, they devised a system whereby stream/river night flow is stored in small reservoirs/ponds locally called *ndiva*. These ponds are normally constructed in the highland zones. Through the use of furrows and channels, the lowland farmers release the stored water during the day for irrigation. This system has helped a lot in solving some of the water-demand requirements for the lowland farmers and has received full support from both groups. Farmers maintain these *ndivas* through communal works during distillation, and in case of major repair (such as leakage) where inputs (such as cement) are required they contribute money or equivalent for the repair.

The privatization process in Tanzania, which used to have nearly 300 parastatals, has been going on for the past 5 years. The public agriculture sector included three major organizations. The largest is the National Food and Agriculture Corporation (NAFCO), the second largest, the Tanzania Sisal Authority (TSA) and the third largest, the Sugar Development Corporation (SUDECO). All the five irrigated sugarcane estates have been privatized and nearly all the sisal estates are gone but it has proven very difficult to find private investors for the NAFCO farms, which are all dealing with food crops including irrigated rice and maize production and rain-fed wheat production. The reason for this may lie in the continued decline in the global prices of major food crops, such as rice and wheat (Denning et al. 1996, 105).

Private investments are also very common in the processing and transportation subsectors. At the moment, however, most of the processing facilities are for rice and there is a shortage of processing capacity for fruits and vegetables. Another service to irrigation, which

has attracted substantial investment, is the manufacturing, importation and servicing of simple equipment such as hand pumps (Palanisami, Internet).

The area of water supply as a service has not attracted private investment. Even in countries such as Zimbabwe, private investment in water infrastructure is undertaken to satisfy the water needs of the investor rather than providing for commercial services to other farmers. The most limiting factor is that current regulations on water allocation and permits are not conducive to private investment in water-supply infrastructure.

## **Commercialization**

Commercial operations, by definition, have to make a profit large enough to justify the investment. Under *Mode of Ownership and Management*, 314, an attempt was made to identify possible key players in an irrigation system. In an ideal setup the cultivator will be the central link in the chain. The farm-gate price that the farmer receives for his products must be high enough to pay for all the inputs, services and labor (including that of the farmer himself) and must provide a modest profit. The same analysis applies to all players in the system. Two fundamental requirements for successful commercial irrigation are a) a viable and fair linkage between all the players and b) each party making a living and profit from its business. If one of the players fails to make a living and profit the whole system will be affected. This section attempts to discuss the findings from Kenya and the other countries on the difficulties of ensuring free and undistorted linkages between different players in an irrigation system.

## ***Profitability***

Profit is the main reason for investing in irrigation although some farmers, communities or countries do it as a survival mechanism. To realize a profit, the farmer must minimize the cost of necessary inputs and maximize income through high farm-gate prices. On both fronts, the existing evidence shows that a smallholder farmer irrigating food crops face many problems. First, it is only in rare cases that the capital cost of irrigation infrastructure has been successfully recovered from farmers. Many schemes are struggling even to recover O&M costs. Therefore, all indications are that privatization and commercialization of services will lead to a steep increase in the costs incurred by the farmer. Further, there is very little indication that the farm-gate price of food crops will increase in the near future. This means that irrigated food production will face declining returns. How then can private investment in irrigated food production by smallholder farmers be justified?

It may seem that private smallholder irrigation will be more profitable if applied in the production of high-value crops for niches. However, there are the problems of accessing these markets as discussed in the Kenyan case study papers. Therefore, it is appropriate that we should now turn to the issue of marketing.

## ***Marketing***

The issue of marketing is touched upon by several of the Kenyan papers but Freeman and Silim (2000) and Scheltema (2000) give it in detail. These two papers show that farmers'

produce is sold either freely to consumers, processors, cooperatives and trades, or under contract to all groups except consumers. Both approaches have their problems as discussed below.

Remote locations with poor transportation and communication make the transaction costs of marketing produce very high. It is, for example, difficult for the farmer to meet contractual requirements of quality and time of delivery. For this reason, it is difficult to secure contracts; or buyers give farmers low prices as a security against expected delays in delivery. Poor communication puts farmers at a disadvantage due to limited availability of market information to them. Often, farmers cause lower prices by competing against each other due to uncoordinated production schedules. Farmers' crops tend to reach the market at the same time and the system swings from periods of glut to periods of shortage. In this situation, and especially with perishable crops, the farmers end up with diminished bargaining power. On the other hand, the small-scale nature of production leads to high collection costs for the buyer, reducing profits and thus the price they can offer to the farmer.

Since irrigation increases the certainty of production, it should make production under contract more viable and attractive. However, very little effort has been made to develop strong marketing institutions. Farmers try to overcome some marketing problems by forming cooperatives to market their produce. However, cooperatives have failed even for highly commercial crops such as coffee and cotton. The main reasons have been corruption and mismanagement but, most importantly, failures to adopt commercial practices (FAO 1999).

### *Equity*

Water is a mobile resource and thus, depending on the size of a water basin, the water may have millions of stakeholders who often have differing and sometimes conflicting demands on the resource. Equity is a term used to refer to fairness in the access, distribution and sharing of the benefits and costs of water by stakeholders. The stakeholders are those who will either benefit from using the water for irrigation or be affected negatively (directly or indirectly) when the water is used for irrigation, or have other interests on the water. Therefore, equity must be established across gender, among farmers within one scheme, between upstream and downstream schemes, across different sectors and between nations.

### *Gender*

Introduction of irrigation should be compatible and enhance a fair division of labor between men and women in the society. If there is an imbalance existing in the demand for labor from men, women and children, efforts should be made to remove this in the choice of design and technology for irrigation. Inequity in income distribution and control is a major problem in rural areas. This is a result of the cultural behavior in rural Africa where either men or women control different crops. For example, in northern Tanzania, women control bananas while men control coffee. In other farming systems, rice is under the control of men while women manage sweet potatoes. Therefore, an irrigation design, which destroys potato fields in favor of rice, will create or increase inequity between men and women.

### ***Among farmers***

Competition for water among users in the same scheme has been discussed in several papers from Kenya, notably by Gichuki (2000). The inequity is caused by many factors that can be grouped into three categories: a) hydraulic and engineering, b) agronomic and c) social. Hydraulic factors lead to tail-end problems where farmers at the end of the scheme get less water. This problem often occurs when water is allocated for a fixed period or time instead of on a quantitative basis, which requires expensive flow-measuring facilities. Agronomic factors cause inequity, for example, through differences of soils, crops or on-farm techniques. Two farmers with differing soils will obtain different benefits from the same amount of water. This will create friction among the farmers. In relation to social factors, it is important that there are strong institutions for distribution of water.

### ***Upstream and downstream relations***

In a watershed or river basin, all water resources are linked and equitable distribution in quantity and quality between upstream and downstream users is often difficult to achieve. Often, upstream users abstract more water and either deplete it through consumptive uses, such as transpiration or through nonconsumptive uses, such as pollution. Often, there is no catchment plan that would place the most polluting uses downstream and nonconsumptive, nonpolluting uses (e.g., hydropower generation) at the upstream end. This problem is a consequence of lack of overlap between watershed boundaries and social boundaries. It is only in rare cases that a catchment falls under the control of one farmer, clan, district or even country. In this situation those in the upstream normally have a first claim on the water and they try to retain most of it as discussed by Gichuki. To ensure equity, it is necessary to develop catchment/basin approaches to water-resources development and use. There should be a negotiated plan acceptable to all stakeholders. The case study shown in box 4 demonstrates a simple idea, which has tremendously improved the downstream-upstream relationship in irrigation systems of the highlands of Tanzania.

### ***Across sectors***

As countries become more developed, utilization of water for irrigation tends to yield lower benefits when compared to other uses, such as domestic, industrial, environmental conservation and leisure. Therefore, opportunity costs of using water in the different sectors become the deciding factor in water allocation. Should water be delivered to Nairobi to serve a tourist paying US\$500 per night in a hotel and thus indirectly use the water to earn foreign exchange or use the same water to irrigate a crop of maize? The theoretical answer to this question can be found in the principle that transferring water from lower- to higher-value uses increases water productivity. In practice, questions regarding policy and politics come into play and the final decision may not make the most economic sense.

### ***Between nations***

Equity between nations in access to riverbasin water is very important in eastern and southern Africa. Most of the river basins stretch over several countries. The Nile basin covers the largest number of countries, nine in total. The concept of holistic integrated catchment/basin

management is difficult to implement with so many different countries involved. These countries are at different levels of economic, social and political development. Close economic partnership between these countries is the key to collaboration in integrated basin management.

## **Outstanding Issues for Research**

The synthesis given in a previous section (*Results and Issues*, 308) has shown that there are many areas where irrigation development in the region is either operating from false premises or is based on outdated approaches, which require urgent revision. At the same time, the region is also endowed with rich experiences from attempts of different countries to develop the irrigation sector. Therefore, a lot can be learned from both successes and failures within the region. However, due to inadequate research, few of these experiences have been put to beneficial use. For this reason, the purpose of this section is to identify critical issues, which require research efforts to develop a firm foundation of information and knowledge for transforming irrigation in the region. The selected issues include policy and the role of government, public institutions and international agencies; technology development; O&M; and commercialization and trade.

### ***Policy and the Role of Government, Public Institutions and International Agencies***

The role of governments is still not very well defined and not uniform in the region. In countries like Sudan, the government controls aspects of irrigation from policy making to actual production. On the other hand in Zimbabwe, for example, most irrigation is outside the direct control of the government. What is the correct balance? The philosophy of market economy dictates that governments should refrain from prescriptive policies that stipulate how much cultivated land should be irrigated. Governments should provide basic conditions for commercially sustainable development of the irrigation subsector. This requires the government to ensure that policies, legislation and strategies are in line with the promotion of effective and productive utilization of water resources for agriculture. These are summarized in the following subsections.

#### ***Policies and policy instruments of the government***

The irrigation subsector is affected by the majority of government sectoral policies. The most important are:

- water resources policy
- agricultural policy, especially the food security strategy
- landownership, tenure and conservation policies

- social and economic infrastructure policy
- transportation and communication policy
- industrial and trade policy

These can be divided into three categories. In the first category is the agricultural policy, especially the food-security strategy. It is under this policy that a national irrigation agenda is normally designed. The second category comprises the water and land policies. These determine the availability of the basic resources to an actually implemented irrigation plan. The rest comprises the third category, which determines the commercial viability of any scheme. Due to poor policy analysis and research, irrigation is often designed only as an instrument of agricultural policy, with limited integration into the other sectoral policies. On the other hand, the high cost of development of irrigation projects is often caused by the fact that they are developed with multiple goals in mind. For example, the Bura scheme was intended to develop remote areas with no infrastructure, in addition to increasing agricultural production and alleviating poverty of the beneficiaries.

Therefore, research on policy analysis is urgently required to answer the following questions:

- How can irrigation be designed and reoriented so as to fully exploit possibilities made available by different sectoral policies?
- Which components of sectoral policies and policy instruments require revision in order to promote the commercial irrigation subsector?
- What are the necessary legal instruments?

### ***Regional collaboration and trade***

Irrigation development can benefit and also contribute to trade in food at the regional level that allows water resources to be put into use in the areas of best comparative advantage for a catchment, basin or country. East and southern Africa, taken together, have abundant water resources, which are currently underutilized because of a mismatch in the physical location of water versus good land for irrigation versus technological and managerial skills for commercial irrigation. Since most of the major rivers in the region cut across several countries, the basin approach cannot be achieved without international partnership. Two communities already exist in the region, namely, the Southern Africa Development Community (SADC) and East Africa Community (EAC). Analysis of policy research is urgently required to evaluate how these and other groupings can be used to promote trade in food and other agricultural products, so as to create a conducive environment for commercial irrigated agriculture in the region.

### ***Database development***

Data on land, water and irrigation are poor in nearly all the countries. Without a radical improvement of these databases, policies, plans, strategies and designs cannot be made with

certainty and are bound to fail. Moreover, private and commercial irrigation as well as equitable allocation of water requires precise planning and management.

There is a need for major research programs by both international and local research organizations to do the following, for example:

- Develop practical methodologies for river-basin analysis to ascertain the potential for irrigation in various catchments/basins, given the specific conditions (e.g., infrastructure) and opportunity cost of using water in other sectors.
- Take advantage of tools such as GIS to develop comprehensive databases and decision-support systems. These will assist planners and designers to test several scenarios and get answers to “what if” questions in the process of policy making and planning agricultural, water resources and irrigation systems. This will, for example, involve the use of reference basins.

### *Existing public schemes*

Many of the public irrigation projects were planned to pursue the policy of national food self-sufficiency. There is also confusion about irrigation’s contribution to poverty alleviation. These have proven to be bad criteria for irrigation development. What is the best way to utilize existing public irrigation schemes? Many say it is privatization. But is this really the right solution for huge infrastructural systems, such as those found in Sudan? Unfortunately, we do not know because of limited research in this area. Further, the failure to find private buyers for irrigated rice and maize farms in Tanzania indicates that private investors are not eager to make further investments in some schemes.

There are five options on how to deal with existing public schemes, which are:

- Optimization, where public schemes are reengineered to emulate private irrigation schemes, and become just as competitive in both costs and benefits.
- Privatization of schemes operated by parastatals.
- Contract-out management and operations. In this case, the government retains ownership especially of water-control infrastructure, but contracts out their O&M to the private sector.
- Management transfer to farmers. This is an option more valid to the tenant-farmer-based irrigation schemes.
- Develop markets for irrigated crops.

Each of these options can find applications depending on conditions in a country, basin or scheme. Therefore, research is required to generate models, which can be used to make decisions on which option to follow and how. The most important factors to be analyzed will include:

- existing skills and management capacities in the government, private contractors and water users



- socioeconomic setup, coherence and local institutions to ensure community cooperation
- type and design of the infrastructure already in place and the O&M requirements
- types of crop being irrigated and the agronomic patterns being followed
- capacity of the private sector to provide input supply and marketing services

## ***Technology Development***

### ***In-field water application***

Since irrigation professionals involved in planning and design are predominantly civil engineers, the choice of technology in many irrigation schemes has been dominated by civil engineering structures and systems. Many of these systems are highly deficient in the aspects necessary for effective management of water in the root zone. This approach should be changed.

The ultimate goal of irrigation technology is to make irrigation a competitive economic enterprise comparable to other sectors in the generation of benefits from the utilization of water. This can be achieved through the development, adaptation and adoption of effective in-field water-application systems. The principles of how this can be achieved are already known. What is needed is an applied and adaptive research program that will develop site-specific technologies to meet the following:

- socioeconomics of land and water
- crops being grown and the agronomic practices and inputs being used
- scale of irrigation
- technical skills of farmers and others of water services
- extent of risk of degradation of land

### ***Water resources development***

The special and temporal variability of rainfall requires technologies for facilitating transfer of water either from periods when water is in high supply to periods of shortage, or areas with high water supply to locations with scarcity, or both.

The first demands water storage systems while the second requires interbasin transfers. The development of effective groundwater strategies is one option of water storage that has not been fully explored and exploited and represents a good area for research. Interbasin transfer of water is only practiced to a small extent in the region. It is a technology that can be used to overcome the mismatched location of water and the best land for irrigation.

## ***O&M***

All the aspects of policy and strategy change discussed in section under *Outstanding Issues for Research* (p. 323) will have tremendous effects on O&M. Much is not yet known on how best to organize O&M under different irrigation strategies and systems. At the moment, O&M services receive little attention and what is received is generally very poor. There is a debate on what the real causes are. Suggested causes include the following:

- Farmers do not pay water charges due to several reasons (e.g., low returns).
- Poor management and corruption within O&M organizations.
- Poor water distribution among farmers, which leads to the breakdown of group cohesion.
- Low technical capabilities of O&M organizations due to lack of specialization.
- The O&M organizations are often not accountable to the farmers.

The challenge for research is to find the best arrangements for ensuring the following:

- The O&M services are efficient in terms of water delivery to the farmers.
- The farmers are charged a fee that is transparently related to the amount of water received, which they can pay.
- The O&M service provision is sustained even if provided by private businesses.

## ***Commercialization and Trade***

Any enterprise that aims at commercialization has as its main motive the making of profits. For many farmers engaged in irrigation, their biggest challenge is marketing and the market forces they have to deal with. Although irrigation improves confidence in production, market forces may work against the farmer. Prices may be reduced due to flooding of the market or buyers may collude to lower prices even during periods of short supply. It is imperative, therefore, that research and training focus on developing strong marketing institutions and build the capacity of individual farmers. Training on managing irrigation according to commercial practices should be strongly emphasized.

## **Conclusions**

From this synthesis, the following conclusions on “The Changing Face of Irrigation in Kenya and Their Relevance to Eastern and Southern Africa” can be made:

1. The database on irrigation is inadequate and of low quality. Any effort aimed at improving the quantity and quality is constrained by technology and low priority accorded to the building of databases.
2. Rainfall is the major source of irrigation water, but its availability and distribution are highly skewed. Lack of water storage exacerbates the situation.
3. The general assumption that there is a scarcity of water in general and for irrigation in particular in Kenya and the region as a whole is somehow misleading. The problem is that large volumes of water may be available for only a short duration and sometimes in a restricted area. People lack the technologies for overcoming its poor spatial and temporal distribution.
4. Many of the problems associated with ownership and accessibility to water stem from the fact that water is viewed as a public good and free access to it is considered as a human right. In all the countries reviewed, water belongs to the state, with rights/permits issued for limited amounts and periods to individuals and companies. Water-rights systems in the region may have contributed to low rates of private-sector investment in irrigation.
5. Landownership and tenure in all the countries are similarly not conducive to the commercial irrigation subsector.
6. Current irrigation technologies practiced in most countries reviewed are dominated by the classical approach of flooding the land to saturate the entire root zone. This approach involves a very low level of water control. Technologies for achieving high levels of water control are available but these need to be promoted vigorously and should be supported by research, training and extension services.
7. In recent years, the ownership and management of irrigation projects are in transition in most countries in the region. The trend is towards privatization and many governments are attempting to transfer the entire management of large irrigation schemes to private companies or WUAs. Parallel to this, private investment in irrigation is gaining momentum with emphasis on high-value export crops such as vegetables and flowers.
8. Irrigation requires a substantial amount of capital investment. Consequently, farmers require assured markets and prices to make a profit. Contrary to this, many farmers in the reviewed countries face marketing problems, which are partly due to lack of research and training in marketing.
9. As a mobile resource, water has numerous stakeholders among whom can be farmers, input suppliers, actors from other sectors and even nations. In all the countries reviewed, conflicts among different stakeholders exist over the distribution and sharing of water resources. To ensure equity, therefore, it is necessary to develop catchment/basin approaches to water-resources development.

## Literature Cited

- Baecher, G.; R. Anderson; B. Briton; K. Brooks; and J. Gaudet. 2000. *The Nile basin-transboundary. Opportunities and constraints analysis*. Washington D. C.: United States Agency for International Development. (<http://www.glue.umd.edu/~gbaecher/recentbooks.d/ETOCA%202000.pdf>)
- Barker, R.; and B. Van Koppen. 1999. *Water scarcity and poverty*. IWMI Water Brief 3. Colombo, Sri Lanka: International Water Management Institute.

- Calder, I. R. 1994. *Eucalyptus: Water and sustainability*. A summary Report. ODA Forestry Series No. 6. London: Overseas Development Administration. 14 p.
- Denning, M.; K. Harnevik; and M. Brdarski. 1996. *Food security in east and southern Africa*. Department for Natural Resources and the Environment/SIDA. Stockholm: Swedish International Development Agency (SIDA). 200p
- EAAFRRO (East African Agricultural and Forestry Organization). 1979. Hydrological Research in East Africa. *East African Agricultural Journal* 43: 248–254. (Special Issue)
- FAO (Food and Agriculture Organization) Website: [www.fao.org/agriculture](http://www.fao.org/agriculture)
- FAO. 1986. *Irrigation in Africa south of the Sahara*. FAO Investment Centre Technical Paper No. 5. Rome: FAO. 175 p.
- FAO. 1995a. *Agricultural investment to promote improved capture and use of rainfall in dryland farming*. FAO Investment Centre Technical Paper No. 10. Rome: FAO. 46 p.
- FAO. 1995b. *Irrigation in Africa in figures*. Water Report No. 7. Rome: FAO. 336 p.
- FAO. 1997. *Small-scale irrigation for arid zones: Principles and options*. Rome: FAO.
- FAO. 1999. *Capital formation in Kenyan farmer-owned cooperatives: A case study*. People's Participation Series no. 12. Rome: FAO. 44 p.
- Freeman, H. A.; and S. N. Silim. 2000. Commercialization of smallholder irrigation: Economic and social implications in semiarid areas of eastern Kenya. Paper presented at the Third SWIM Workshop on the Changing Face of Smallholder Irrigation in Kenya, 19 October 2000, Nairobi, Kenya.
- Gichuki, F. N. 2000. Water scarcity and conflicts: A case study for the upper Ewaso Ng'iro North basin. Overview of irrigation development in Kenya. Paper presented at the Third SWIM Workshop on the Changing Face of Smallholder Irrigation in Kenya, 19 October 2000, Nairobi, Kenya.
- Gunnel, Barbara. 1986. The great Bura irrigation scheme disaster. *African Business* 18 (April 1986).
- Hornung, M.; and M. D. Newson. 1986. Upland afforestation: Influences on stream hydrology and chemistry. *Soil Use and Management* 2(2): 61–65.
- Huggins, C. 2000. Water policy and law in a water scarce country: Implication for smallholder irrigation in Kenya. Paper presented at the Third SWIM Workshop on the Changing Face of Smallholder Irrigation in Kenya, 19 October 2000, Nairobi, Kenya.
- ICID (International Centre for Irrigation and Drainage). *Country profiles*. <http://www.icid.org/country.html>
- Kabutha, C.; and C. Muteru. 2000. From government to producer-managed smallholder rice schemes: The case of the Mwea irrigation scheme. Paper presented at the Third SWIM Workshop on the Changing Face of Smallholder irrigation in Kenya, 19 October 2000, Nairobi, Kenya.
- Lambert, R. A.; and R. D. Faulkner. 1989. A low cost irrigation package for micro-scale irrigation in Africa. In *Land and Water Use*, ed. Dodd and Grace, 603–611. Rotterdam: Balkema.
- Mati, B.M. 2000. Use of information systems for smallholder irrigation and drainage planning and management. Paper presented at the Third SWIM Workshop on the Changing Face of Smallholder irrigation in Kenya, 19 October 2000, Nairobi, Kenya.
- Matsika, N. 1996. Challenge of independence: Managing technical and social worlds in a farmer managed irrigation schemes. In *The practices of smallholder irrigation. Case studies from Zimbabwe*, ed. E. Mazungu and P. Van der Zaag, 29–46. Harare: University of Zimbabwe Publications.
- Mazungu, E.; and P. Van der Zaag, eds. 1996. *The practice of smallholder irrigation: Case study from Zimbabwe*. Mount Pleasant, Harare: University of Zimbabwe. 235 pp.
- MoAC (Ministry of Agriculture and Cooperative). 1999. *National irrigation development plan*. Kenya.
- MoFA and DANIDA (Ministry of Foreign Affairs and Danish International Development Agency). 1997. *Small holder irrigation improvement*. Dar es Salaam. 30 pages.

- MoW (Ministry of Water). 2000. *Towards a management strategy for the Usangu catchment: Sustainable management of the Usangu wetland and its catchment (SMUWC)*. Interim Report. Mbeya. 107 pp.
- Mrema, G. C. 1984. Development of small-holder irrigation in Tanzania: Problems and prospects. In *Proceedings of African Regional Symposium on Small Holder Irrigation, 5–7 September 1984, Harare, Zimbabwe*.
- Murray-Rust, D. H. 1973. Soil erosion and reservoir sedimentation in a grazing area west of Arusha, Northern Tanzania. In *Studies of soil erosion and sedimentation in Tanzania*, ed. A. Rapp, L. Berry and P. Temple, 325–349. Research Monograph Number 1. Dar es Salaam: Bureau of Resources Management and Land Use Planning. University of Dar es Salaam.
- Ngigi, S. N. 2000a. Preliminary evaluation of irrigation development in Kenya. Paper presented at the Third SWIM Workshop on the Changing Face of Smallholder Irrigation in Kenya, 19 October 2000, Nairobi, Kenya.
- Ngigi, S. N. 2000b. Review of irrigation development in Kenya. Paper presented at the Third SWIM Workshop on the Changing Face of Smallholder Irrigation in Kenya, 19 October 2000, Nairobi, Kenya.
- Ong, C.; and F. Oregó. 2000. Link between land management, sedimentation, nutrient flows and the smallholder irrigation in the lake Victoria basin. Paper presented at the Third SWIM Workshop on the Changing Face of Smallholder Irrigation in Kenya, 19 October 2000, Nairobi, Kenya.
- Oweis, T.; A. Hachum; and J. Kijne. 1999. *Water harvesting and supplementary irrigation for improved water use efficiency in dry areas*. SWIM Papers No. 7. Colombo, Sri Lanka: International Water Management Institute.
- Palanisami, K. *Economics of irrigation technology transfer and adoption*. (FAO, Internet).
- Rockström, J.; P. E. Jansson; and J. Barron. 1998. Seasonal rainfall partitioning under runoff conditions and sandy soil in Niger: On farm measurements and water balance modeling. *Journal of Hydrology* 210: 68–92.
- Scheltema, W. 2000. Smallholder management of irrigation in Kenya. Overview of irrigation development in Kenya. Paper presented at the Third SWIM Workshop on the Changing Face of Smallholder Irrigation in Kenya, 19 October 2000, Nairobi, Kenya.
- Seckler, D.; D. Loldern; and R. Barker. 1999. *Water scarcity in the twenty-first century*. Water Brief 1. Colombo: International Water Management Institute. pp. 11.
- Sijali, I. V.; and R. A. Okumu. 2000. New irrigation technologies in Kenya. Paper presented at the Third SWIM Workshop on the Changing Face of Smallholder Irrigation in Kenya, 19 October 2000, Nairobi, Kenya.
- Stern, R. D. 1980. The calculation of probability distribution for models of daily precipitation. *Arch. Met. Geoph. Ser. B*. 28: 137–147.
- USAID (United States Agency for International Development). 1982. *Sudan: The Rahad irrigation project*. A.I.D Project Impact Evaluation Report No. 13. Washington D.C.
- Withers, B.; and S. Vipond. 1974. *Design and practices*. London: BT Batsford Limited. pp.306.
- World Bank. 1990. *Sudan—Reversing the economic decline*. Country Economic Memorandum. Washington, D.C.



**Postal Address**

P O Box 2075  
Colombo  
Sri Lanka

**Location**

127, Sunil Mawatha  
Pelawatta  
Battaramulla  
Sri Lanka

**Telephone**

+94-1-787404, 784080

**Fax**

+94- 1-786854

**E-Mail**

[iwmi@cgiar.org](mailto:iwmi@cgiar.org)

**Website**

<http://www.iwmi.org>



FUTURE  
HARVEST  
IWMI is a Future Harvest Center  
supported by the CGIAR

**ISBN 92-9090-475-5**